

# NON TRES

**703 F** ETC  
OWNER'S MANUAL

This User Manual is considered a permanent part of the Motorcycle and should be given to the new owner of the vehicle when the vehicle is resold.

The vehicle information in this User Manual is the latest production information before printing. Guangdong Tayo Motorcycle Technology Co., Ltd. reserves the right to modify the content and design of this manual at any time, and does not assume any responsibility for it.

The content of this User Manual is updated quickly, and the final website shall prevail, and the PDF file of this manual is available for download on the official website.

The vehicles illustrated in this User Manual are for reference only, and everything is based on your actual vehicle.

The final interpretation right of this User Manual is owned by Guangdong Tayo Motorcycle Technology Co.Ltd.

No part of this manual may be copied or copied without permission.



# Precautions

Thank you for choosing Zontes brand motorcycles. We design, test and manufacture this model of motorcycle for you with advanced technology, providing you with interesting, fun and safe driving. Once you are fully familiar with the essentials in this manual, you will find driving a motorcycle an exhilarating sport and a real joy of driving

For your driving safety, please note the following:

- Please be sure to read this User Manual carefully;
- Please refer to the suggestions and operating procedures in this manual;
- Please carefully read this manual and the safety tips pasted on the motorcycle body.

- The illustrations in this manual are based on the highest configuration 703F. Please refer to the actual product.

## Vehicle model, engine model

Vehicle	Engine model
703F	ZT370MU

# Precautions

## Safety Precautions:

The safety of your and others life the is very important. Be sure to obey the traffic rules and drive safely. To help you drive safely, we provide detailed instructions and other relevant information on body stickers and in this manual to protect you or others from potential hazards.

This manual has safety warning symbols  and the following three warning words: danger, warning, and caution.

The following signal words and logos appear in this note

The meaning of the three warning words on the book and in your motorcycle is shown below:

### DANGER

- Failure to follow the hazard warning, it will result in serious casualties.

### WARNING

- Failure to follow warnings, it may result in serious casualties.

### CAUTION

- Failure to follow the cautionary instructions will result in damage to the motorcycle and property.

# Catalog

Riding safely 1-1

Component installation location 2-1

PKE keyless control system 3-1

Left and right handlebar control system 4-1

Instrument 5-1

Maintenance 6-1

Troubleshooting 7-1

Maintenance and storage 8-1

Specification 9-1

<b>Riding safely</b>	<b>1-1</b>
Driver safety	1-1
Helmet and eye protection	1-1
Gloves	1-1
Long-sleeved shirts/jerseys	1-1
Boots	1-1
Carbon monoxide poisoning	1-2
Load	1-3
Genuine ZONTES accessories	1-3
Safe driving tips	1-3
Start the engine	1-5
Stop the engine	1-5
Driving	1-6
Braking and stopping	1-8
Anti-lock Braking System (ABS)	1-9
Traction Control System (TCS)	1-9
Turn off the operation of TCS	1-10
New motorcycle break-in period	1-11
Engine break-in period	1-11
The speed of the engine	1-11
Break-in of the tires	1-11
Avoid running the plant for a long time	1-12
Allow the oil to circulate before driving	1-12

## **Component installation location** ----- 2 - 1

## **Left and right handlebar control systems** ----- 3 - 1

## **Passive keyless entry system** ----- 4 - 1

Use of inductive keys	4-2
Non-electric induction start mode	4-2
PKE power-on	4-3
PKE power-off	4-3
PKE fault prompt	4-5

## **Instrument panel** ----- 5-1

<b>Maintenance</b>	<b>6-1</b>
First maintenance	6-1
Maintain safety	6-1
Initial routine inspection	6-2
Regular maintenance of the table	6-3
Pre-driving inspection	6-7
Battery removal	6-9
New battery startup	6-9
Chargingport	6-10
Charger Instructions	6-10
Cleaning the battery	6-10
Replace the battery	6-10
Use and maintenance	6-10
Toolkit	6-12
Left and right fairings(quick release)	6-12
Head cowl panel(quick release)	6-12
Windshield assembly maintenance	6-13
Engine guard removal	6-14
Muffler	6-14
Check the spark plugs	6-15
Spark plug replacement	6-15
Install the spark plugs	6-15
Engine oil	6-16
Check the engine oil level	6-16
Replace the engine oil	6-17
Change engine oil and oil filter	6-17
Coolant	6-20
Engine coolant (antifreeze)	6-21
Air filter	6-22
Drift tube	6-24
Engine idle check	6-25
Adjust the brake level play	6-25
Check the clutch lever free play	6-26
Side stand	6-27
Shift level	6-28
Rear armrest (rear shelf)	6-28

Fuel tank cap .....	6-29
Adjust the front suspensionsystem .....	6-30
Adjust the rear suspensionsystem .....	6-31
Suspension system adjustment recommendations .....	6-33
Upper triple clamp damping rubber troubleshooting .....	6-34
Transmission chains .....	6-35
Check the drive chain .....	6-35
Cleaning and lubrication of transmission chains .....	6-35
Adjustment of the transmission chain .....	6-36
Check the tightness of the transmission chain .....	6-37
Adjust the tightness of the transmission chain .....	6-37
Check the chain life .....	6-38
Check the anti-wear block of therear fork .....	6-39
Tire (Inspection/Replacement) .....	6-40
Wheels .....	6-41
Brake .....	6-42
Headlight adjustment .....	6-44
Installation additional electrical accessories .....	6-45

## **Troubleshooting -----7-1**

Fuse .....	7-1
Catalyst .....	7-2
Troubleshooting .....	7-3
Fuel system checks .....	7-3
The engine does not work .....	7-3
The engine is underpowered.....	7-3
Carbon deposit cleanup.....	7-4
EFI precautions .....	7-4
EFI fault code .....	7-7
LCM function fault code .....	7-9
LCM key fault code .....	7-10

# Catalog

Maintenance and storage	8-1
Storage	8-1
Motorcycle	8-1
Fuel oil	8-1
Engine	8-1
Battery	8-1
Maintenance	8-1
Tire	8-1
Motorcycle surface	8-1
Method to re-enable	8-2
Rust prevention	8-2
Key points for rust prevention	8-2
How to prevent rust	8-2
Clean the motorcycle	8-3
Cleaning precautions	8-5
Transportation	8-7
Engine code	8-8
Frame code	8-8
Nameplate	8-8

<b>Specification</b>	<b>9-1</b>
----------------------	------------

<b>Circuit schematic</b>	<b>10-1</b>
--------------------------	-------------

## To enhance your safety, please follow the following guidelines:

Carry out all the daily and regular inspections specified in this manual.

### Driver safety

Drivers and passengers must wear appropriate protective gear at all times, including: certified helmets, gloves, long-sleeved shirts/jerseys, trousers/cycling pants, and boots that cover bare feet/cycling boots.

### WARNING

• **Do not wear any loose clothing that may entangle the vehicle or hang on branches and bushes.**

### Helmet and eye protection

A certified helmet can mitigate head and brain injuries, and in the event of an accident, using a helmet can greatly reduce the risk of brain injury.

The helmet you choose should meet the standards of your country or region and be the right size. A helmet with face protection is a better choice because it will protect against impacts from the front at the same time, including insects, flying stones, dust, scattered parts, etc., allowing you to make timely judgments about what is happening on the road and drive the motorcycle safely.

Semi-protective helmets do not provide the same protection for the face and jaw, so if you are wearing a semi-protective helmet, you should use a removable face shield and goggles.

### Gloves

Finger gloves are effective in protecting hands from wind, sun, heat, cold and splashes. Well-fitting gloves help you stay on top of your way and reduce hand fatigue. Conversely, if the gloves are too bulky, it will be difficult to operate the vehicle.

In the event of an accident or rollover, a pair of sturdy reinforced motorcycle gloves can better protect your hands.

### Long-sleeved shirts/jerseys

Wear a jacket/long-sleeved shirt and pants or a full cycling suit. High-quality protective gear is more comfortable and prevents adverse environmental factors from distracting you. In the event of an accident, high-quality protective gear made of strong materials can mitigate or even prevent injury.

### Boots

Always wear protective gear that protects your feet and bare feet; When the engine or exhaust gas is running, it will heat up and become very hot, which may cause burns.

# Riding safely

## DANGER

· For your life safety, please avoid driving motorcycles at high speed in heavy rain, wind, ice and snow.

---

## Carbon monoxide poisoning

When the engine is running, it produces carbon monoxide, a colorless, odorless, odorless gas that can cause headaches, dizziness, drowsiness, nausea, confusion, and eventually death when inhaled.

In confined or unventilated spaces, the lethal level of carbon monoxide can last for hours or days, leaving your body quickly unable to support yourself and unable to save yourself, if you feel carbon monoxide poisoning, leave the area immediately, get some fresh air and go to the hospital.

## WARNING

· Running a motorcycle's engine in a confined or semi-confined space may result in a rapid build-up of toxic carbon monoxide gas.

· Limit the engine of the motorcycle to running in a well-ventilated outdoor area.

---

## Load

Accessories with extra weight, or accessories that easily block wind such as wind deflectors, backrests, saddles, cushions, suitcases, etc., should be installed as low as possible, close to the body and close to the center of gravity. Poor installation will shift the center of gravity and bring danger, the key point of installing accessories is: pay attention to left and right balance and firm stability. Poorly installed fittings or poorly designed accessories can cause maneuvering difficulties and endanger driving safety.

When loading, the cargo should be fixed in a low position as much as possible, as close to the motorcycle as possible. If the goods are not fixed correctly, the center of gravity will be raised, which will make the motorcycle difficult to control and seriously affect the driving safety. The size of the cargo affects the air resistance and affects the handling of the motorcycle. Please balance the items on the left and right sides of the motorcycle and secure the cargo.

The total weight of the driver, occupants, accessories and cargo must not exceed the limit of the maximum load.

### **MAX load:**

197 kg

## Ride within your abilities

Never ride beyond your personal abilities or exceed speeds that are safe under the conditions. Fatigue and negligence can impair your ability to make correct judgments and ride safely.

## Genuine ZONTES accessories

Choosing accessories for your vehicle is an important decision, and genuine parts are only available on our website and dealers, which are designed, tested, and approved for use on our vehicles.

Companies that are not affiliated with ZONTES are also manufacturing parts and accessories for use in zontes vehicles or providing other modifications. ZONTES is not responsible for testing these products that are not manufactured and manufactured by ZONTES company, and ZONTES does not endorse and do not recommend the use of accessories that are not sold by ZONTES, even if they are sold and installed by ZONTES's dealers.

## Safe driving tips

If you are driving this type of vehicle for the first time, we recommend that you practice on non-public roads until you are familiar with the control and handling methods of the motorcycle.

Driving with one hand is dangerous, so keep your hands firmly on the handlebars and keep your feet on the resting pedals. Under no circumstances should you take your hands off the handlebar.

Reduce your speed to a safe speed before you want to steer.



The road surface is wet and smooth, the tire friction will be reduced, and the braking ability and cornering ability will naturally decrease, so it is necessary to slow down in advance.

Crosswinds are usually most likely to occur at tunnel exits, in valleys or when large vehicles are overtaking from behind, so you must be careful to stay calm, slow down, obey traffic rules and limit speed.

## Start the engine

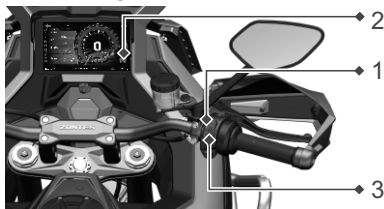
Whether the engine is cold or hot, please follow the instructions below to start the engine.



1. Confirm that the engine cut-off switch is in the  (Run) position.
2. Shift the transmission into neutral " **N** ". The neutral indicator light will illuminate.
3. Squeeze the clutch lever and press the starter switch. With the switch in the "  " position, the engine will start.

### WARNING

- Never start or run the engine in a confined area.
- Exhaust fumes are poisonous and can cause loss of consciousness and death within a short time.
- Always operate the motorcycle in an open area or where ventilation is adequate.

### CAUTION

- Do not operate the starter continuously for more than five seconds, as the starter motor may overheat and the battery will be discharged.
- Wait 15 seconds between each operation of the starter to allow for cooling and battery recovery.
- Do not allow the engine to idle or extended periods, as this may cause overheating and lead to engine damage.

## Stop the engine

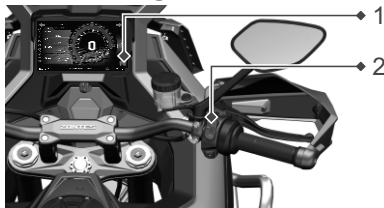

Completely stop the engine:

1. Select neutral " **N** ".
2. Turn the ignition switch to the  (OFF) position.

### WARNING

- Normally, the engine should be stopped by turning the ignition switch to the  (OFF) position. The engine stop switch is for emergency use only.
- Do not turn the ignition switch ON while the engine is stopped, as this may cause electrical damage.

## CAUTION

• **It is strictly prohibited to allow the rear wheel to spin for extended periods while the engine is off. Any damage to the vehicle (including the engine) resulting from such operation shall be deemed as improper handling and will not be covered under the warranty.**

## Driving

After starting the engine, if you need to move the vehicle, engage first gear and slowly release the clutch lever to allow the motorcycle to begin moving smoothly. Once the speed increases and the vehicle stabilizes, retract both feet and place them on the footpegs.

## WARNING

• Do not wear loose clothing that may get caught on the motorcycle, branches, or shrubs.

• Avoid excessively high engine RPM when riding uphill, as this can easily damage internal engine components.

• Do not coast downhill with the engine turned off, as this may shorten the lifespan of the catalytic converter inside the muffler.

## • When the engine is cold:

1. With the transmission in neutral and the clutch lever pulled in.
2. If the transmission is not in neutral, the side stand must be fully retracted, and the clutch lever must be pulled in. The tip-over switch will cut off fuel supply and ignition if the motorcycle falls over, causing the engine to stop. Once the issue is resolved, normal ignition can be resumed.

## DANGER

• **This motorcycle is equipped with an interlock switch for the ignition and starter circuits. The engine can only be started under the following conditions:**

1. The transmission is in neutral, and the clutch lever is pulled in.
2. The tip-over switch will cut off fuel injection and ignition if the motorcycle tips over, causing the engine to stop. After the motorcycle is upright again, turn the engine stop switch to RUN and start the engine.

## • When the engine is cold

1. Ensure the transmission is in neutral.
2. Keep the throttle in the idle position.
3. Pull in the clutch lever, then press the electric start button  to start.

### • If the engine is difficult to start when cold

1. Ensure the transmission is in neutral.
2. Pull in the clutch lever, open the throttle slightly (about 1/8 turn), then press the electric start button  to start.
3. Once the engine starts, allow it to continue running until fully warmed up.
4. If the engine remains difficult to start after multiple attempts, it may be flooded. Perform the cylinder clearing procedure: with the transmission in neutral and the clutch lever fully pulled in, hold the throttle wide open for 3 seconds, then press the starter button for 3 seconds. This procedure may be repeated as needed.

#### CAUTION

- **Starting the engine:** After the vehicle is unlocked and the system is powered on, check whether the engine stop switch is in the  position.
- The colder the weather, the longer the engine requires to warm up. Operating the motorcycle after the engine is fully warmed up helps reduce engine wear.

### • When the engine is hot

1. Ensure the transmission is in neutral.
2. Keep the throttle in the idle position.
3. Pull in the clutch lever, then press the electric start button  to start.

### • If the engine is difficult to start when hot

1. Ensure the transmission is in neutral.
2. Pull in the clutch lever, open the throttle slightly (about 1/8 turn), then press the electric start button  to start.
3. If the engine remains difficult to start after multiple attempts, it may be flooded. Perform the cylinder clearing procedure: with the transmission in neutral and the clutch lever fully pulled in, hold the throttle wide open for 3 seconds, then press the starter button for 3 seconds. This procedure may be repeated as needed.

#### WARNING

- Develop the habit of retracting the side stand, returning the throttle to idle, and pulling in the clutch lever before starting the engine to prevent accidental forward movement in case of error. The motorcycle can only be started when the side stand is retracted and the clutch lever is pulled in.
- **Do not attempt to start the motorcycle if fuel is insufficient or engine oil level is low!**

# Riding safely

## Braking and parking

1. Turn the throttle grip forward to fully release the throttle.
2. Apply both the front brake lever and the rear brake pedal simultaneously.
3. If parking the motorcycle on a gentle slope using the side stand, try to position the front of the motorcycle facing uphill to prevent the motorcycle from tipping over due to rotation of the side stand.
4. Turn the engine stop switch on the right handlebar to the OFF position to stop the engine.
5. Turn the handlebar fully to the left, then press the "  " button for 2–3 seconds. The motorcycle will automatically lock the steering and power off.
6. Rock the handlebar to confirm that the steering is locked.

## DANGER

- At higher speeds, braking distance increases accordingly. Always maintain sufficient distance from the vehicle or object ahead to allow for safe braking, otherwise a collision may occur.
  - Using only the front brake or the rear brake is dangerous and can cause skidding and loss of control. Use the braking system gently on wet or slippery surfaces and when turning. Emergency braking on uneven or slippery surfaces may cause loss of control.
  - Emergency braking while turning may cause loss of control. Brake before entering a turn to reduce speed.
  - The muffler is very hot while the engine is running and shortly after it stops. Do not touch it to avoid burns.
  - Using only the rear brake will accelerate wear of the braking system and gradually increase braking distance.
  - After riding, the surface of the muffler and its heat shields remain hot. Do not touch or lean against them to avoid burns or even fire.
-

**Anti-lock Braking System(ABS)**

This model is equipped with an Anti-lock Braking System (ABS) for both the front and rear wheels, which prevents prolonged wheel lock-up during emergency braking.

**⚠ CAUTION**

- ABS does not reduce braking distance. Under certain conditions, ABS may result in longer braking distances.

- ABS does not function at speeds below 10km/h. During braking, the brake lever or brake pedal may pulsate. This is normal.

- Always use the recommended front/rear tires to ensure proper ABS operation.

- When lifting the rear wheel off the ground and rotating it, the ABS indicator light may illuminate and the ABS system may deactivate. After each time the rear wheel is lifted and rotated, be sure to restart the motorcycle's electrical system to restore normal ABS operation.

- If the indicator light exhibits any of the following conditions, there is a serious problem with your ABS system. In this case, reduce speed and have the system inspected at an authorized ZONTES dealer as soon as possible.





1.The indicator light remains illuminated or flashes while riding.

2.The indicator light does not turn off when the speed exceeds 5 km/h.

3.The ABS indicator light is on. The brakes operate normally, but cornering ABS or full ABS function may be lost.

**Traction Control System (TCS)**

1.The TCS on this vehicle is enabled by default. Each time the vehicle is turned off and then restarted, TCS will automatically return to the enabled state.

2.The TCS function is indicated on the instrument panel by the "  " icon. When the "  " light is on, the TCS function is disabled. When the "  " light is off, the TCS function is enabled. When the "  " light flashes rapidly, TCS is actively working. When the "  " light is illuminated steadily, there is a TCS malfunction. In this case, reduce speed and have the system inspected at an authorized ZONTES dealer as soon as possible.

**⚠ CAUTION**





- TCS can be independently disabled only in OFF ROAD mode or RIDER mode.

## Procedure to disable or enable TCS

### To Disable:

1. Switch to OFF ROAD mode or RIDER mode, ensure the throttle grip is fully closed, then press and hold the "M" button to open the riding mode menu. Press the M button briefly, or press the left/right button on the 5-way control to select the TCS option. Use the up/down buttons to select OFF, then press the OK button briefly to disable TCS.
2. If the TCS indicator " " on the main display lights up, TCS has been disabled.





### To Enable:

1. Switch to OFF ROAD mode or RIDER mode, ensure the throttle grip is fully closed, then press and hold the "M" button to open the riding mode menu. Press the M button briefly, or press the left/right button on the 5-way control to select the TCS option. Use the up/down buttons to select the desired TCS level, then press the OK button briefly to enable TCS.
2. If TCS is disabled while the vehicle is stationary, briefly pressing the M button to switch riding modes will automatically enable TCS.
3. If the main display's TCS indicator " " is off and the " " light is not illuminated, TCS is enabled.
4. Briefly press the OK button to open the quick menu. In the TCS function section, briefly press the "↑" button. If the TCS icon in the quick menu turns green and both the " " and " " indicators are off, TCS is enabled.

## CAUTION

• **Disable the TCS function in advance when aggressive riding is required, as it may otherwise affect the riding experience.**

---

1. When the main stand is deployed and the throttle is applied, or when the vehicle is stuck in mud or other soft surfaces—if the front wheel is not rotating while the rear wheel spins continuously for 180 seconds—both the ABS and TCS will report faults. In this condition, TCS function is lost and the riding mode cannot be switched. To restore normal operation, turn the vehicle power off and then on again, then ride at a speed above 5 km/h to allow the ABS system to complete self-diagnosis. Once the ABS system passes self-test and both the " " and " " indicators turn off, riding mode switching will become available.
2. When an ABS wheel-speed related fault occurs, TCS will also report a fault, and the " " indicator will illuminate. After the ABS function returns to normal, turning the motorcycle off and then on will restore TCS function, at which time the " " indicator will turn off.

**New motorcycle break-in period**

Proper break-in procedures extend the motorcycle's service life and optimize its performance. The correct break-in method is outlined below.

**Engine break-in period**

The break-in process refers to the initial period of operation for a new vehicle.

Specifically, internal friction within the engine is higher when its components are new. As the engine continues to run, the parts gradually "seat" themselves, significantly reducing this internal friction.

A careful break-in period ensures lower exhaust emissions and optimizes the performance, fuel economy, and service life of the engine and other motorcycle components.

**During the first 1,000km:**

- Do not use full throttle.
- Always avoid high engine rpm.
- Avoid prolonged riding at a constant engine speed, whether high or low.
- Except in emergencies, avoid harsh starts, stops, and rapid acceleration.
- Do not exceed three-quarters throttle opening.

**From 1000 to 1500 km:**

- Engine rpm may be gradually increased to the rev limit for short periods.

**Initial 0-1000 km:**

MAX engine speed: 6000rpm

**During 1000-2500 km:**

MAX engine speed:10000rpm

**Both during the break-in period and after completion:**

- Do not overwork the engine when it is cold.
- Do not allow the engine to labor. Always downshift before the engine begins to "struggle."
- Do not ride with the engine rpm unnecessarily high.

**Engine speed**

To protect engine components, the engine speed is limited to 6,000 rpm in neutral (N) and to 11,000 rpm in all other gears (During the break-in period of 0–1,000 km, gears 1–6 are limited to 7,000 rpm. This limit is removed after 1,000 km). When the engine reaches the limited speed, the rpm will automatically adjust around that limit, resulting in normal speed fluctuations.

**Tire run-in**

Similar to engine break-in, new tires require proper break-in to ensure optimal performance. During the first 150 km of use, gradually increase the lean angle when cornering to wear in the tire's contact surface for improved grip. Avoid sudden acceleration, sharp turns, and emergency braking during the initial 150 km of new tire use.

## DANGER

Riding safely

• If tires are not properly broken in, it may cause slipping and loss of control. Exercise extra caution when riding after tire replacement. Follow the instructions in this section to correctly break in tires. During the first 150 km of use, avoid sudden acceleration, sharp turns, and emergency braking

---

### Avoid prolonged full-throttle operation

Avoid prolonged full-throttle operation. Since the engine is in a new condition, do not overload it during the first 1,000km. During the break-in period, internal engine components undergo mutual wear and polishing to achieve proper operating clearances. Throughout this process, prolonged full-throttle operation or any conditions that may cause engine overheating must be avoided.

### Circulate oil before riding

**Before starting a cold engine, always check the oil level in the engine oil sight glass. If the oil level is low, replenish with an appropriate type and quantity of oil.**

Whether the engine is hot or cold, allow the engine to idle sufficiently before riding. This ensures that oil flows to all lubrication points.

# Component Installation Location

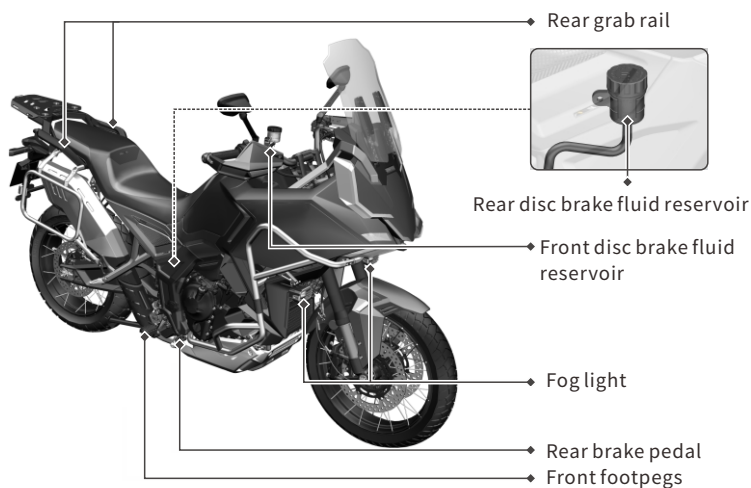
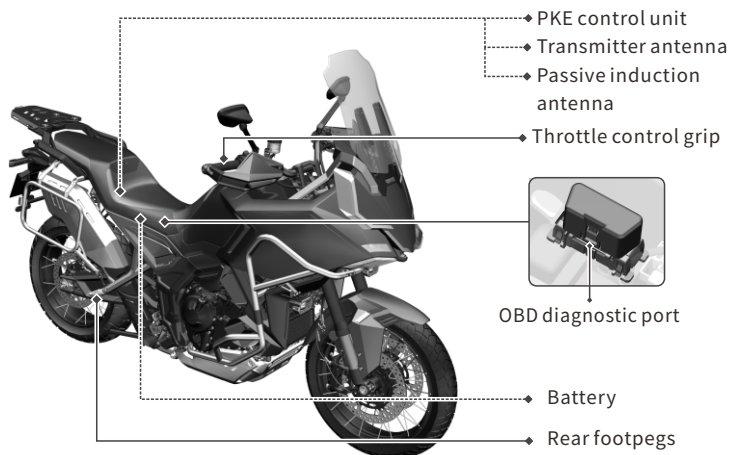

# Component Installation Location

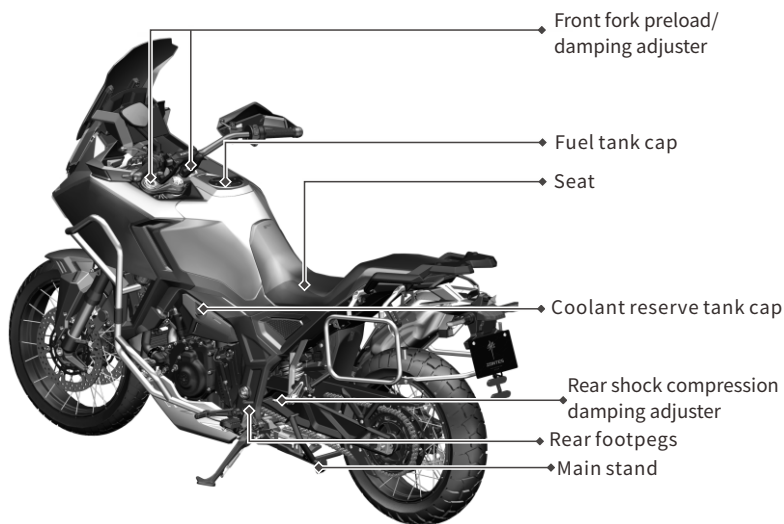
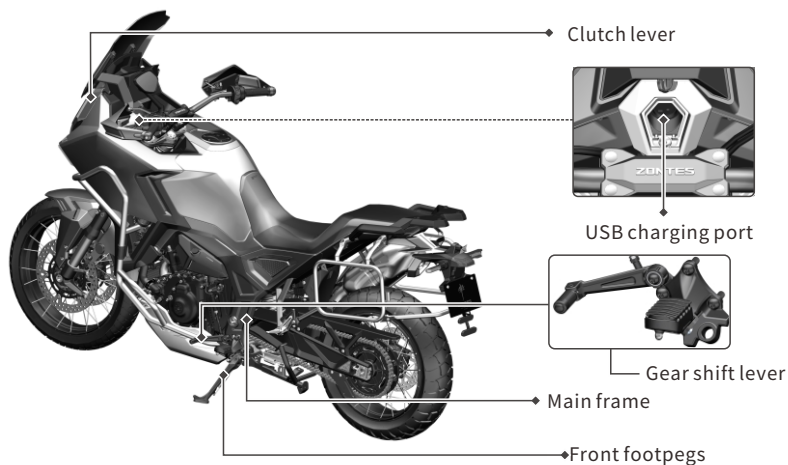

# Left and Right Handlebar Control Systems

## Left handlebar switches

### Cruise control switch

#### RES/+ SET/-

Used to adjust cruise control speed. Briefly press "RES/+" or "SET/-" to increase or decrease speed by 1 km/h. (Refer to the instrument panel's cruise control section for detailed instructions.)

### Turn signal switch:

Push the switch to the left ← to activate the left turn signals. Push to the right → to activate the right turn signals. The corresponding indicator on the instrument panel will illuminate simultaneously.

**Hazard warning switch:**  
Press the button to activate all four turn signals simultaneously, alerting surrounding vehicles to potential hazards.

**OK button / Directional toggle (5-way switch)**

**Horn button:**  
Press the button to sound the horn.

### High/Low beam and passing light switch:

Default state: Low beam. Push upward to activate high beam. Push downward to activate passing light

☰☐: High beam

☷☐: Low beam

☷☐: Passing light

### SEAT switch:

Briefly press to unlock the seat lock.

### Fog light switch

Press briefly to turn on the fog lights; press again briefly to turn them off. Do not leave the fog lights on for extended periods while idling, as this may trigger a voltage warning.



# Left and Right Handlebar Control Systems

## Right handlebar switches



### ⏻ Power button

Short press: Powers on the motorcycle.

Long press: Powers off the motorcycle.

### ⏻ Engine stop/ignition switch

This rocker switch is designed as follows: Set to the "Q" position: Circuits are connected, allowing engine ignition. Set to the "⊗" position: Ignition circuit is completely cut off, preventing engine start (can be used for emergency shutdown).

### ⚡ Electric start switch

Pressing this button engages the starter circuit. To start the engine, ensure the side stand is retracted, the engine stop switch is in the "Q" position, and the brake lever is firmly squeezed

### M switch

The M button can be used to switch riding modes only when:

The engine stop switch is in the RUN position. The throttle grip is fully closed (at idle position), and Cruise control is not active.

Press the M button briefly to cycle through the following five riding modes:

🏍️: SPORT mode

🛣️: ROAD mode

☁️: RAIN mode

⚡: OFF ROAD mode

👤: RIDER mode

## ⚠️ CAUTION

• Do not crank the engine for more than 5 seconds per attempt during continuous starting, as excessive power discharge may cause abnormal heating of the electrical circuit and starter motor. If the engine fails to start after several attempts, stop and inspect the fuel supply system and starting circuit system.

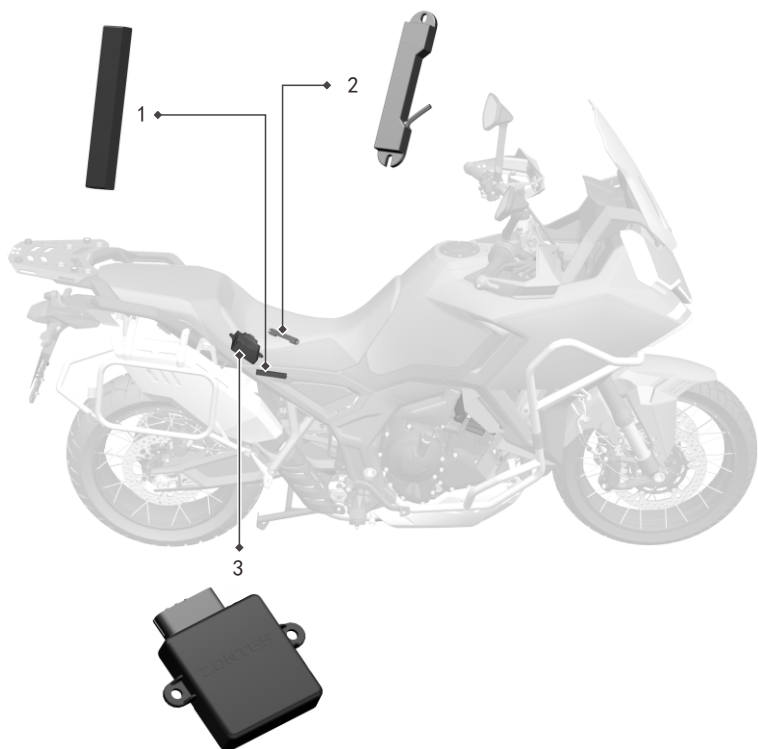

3D antenna sensing area



4

## PKE (keyless entry system) instructions for use:

- Low-frequency transmitting antenna (Fig.1)
- Non-electric inductive antenna (Fig.2)
- 3rd generation PKE host (Fig.3)
- Proximity key (Fig.4)

# Passive Keyless Entry System

## Use of inductive key

The motorcycle is equipped with two smart keys. Please store one securely as a backup.

PKE Both smart keys have barcode stickers attached, with codes corresponding to the barcode on the PKE control unit. The PKE unit automatically recognizes the key closest to the motorcycle without requiring activation. At any given time, only one smart key can be active.

### **⚠ CAUTION**

• The smart key is equipped with green and red LEDs that flash during motorcycle detection. The LED flashes green when the smart key battery has sufficient power. The LED flashes red when the battery is low (immediately after battery installation, both red and green LED will flash once simultaneously). Due to the capacity limitations of CR2032 coin cell batteries, the typical service life is approximately 18 months (actual duration may vary based on usage). If your smart key becomes unresponsive or the indicator flashes red, consider replacing the key battery.

## Non-electric induction start mode

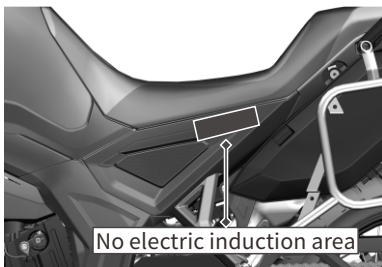

When the inductive key battery is lower there is no key battery, it can be powered on through the non-electric induction mode. The specific steps are as follows:

- Press and hold the " ⏻ " button on the right hand handle when the vehicle is turned off and the faucet lock is closed, and the first "drop" sound is heard.
- Within 5 seconds, place the key sensing area (Fig. 4) against the non-electric sensing area.

### **⚠ CAUTION**

- Alternatively, first place the key sensing area (Fig. 4) flush against the power-off induction area, then perform the steps described above.
- After powering on via power-off induction mode, the system will no longer detect the key. Remember to power off the vehicle when leaving it unattended.

## PKE power-on

Briefly press the "⏻" button. The turn signals will flash twice, the steering lock will automatically disengage, followed by two audible beeps ("di-di"), indicating the circuit is connected.

## ⚠ CAUTION

•If the steering lock fails to unlock, it may be because the handlebar is obstructing the lock pin. Gently turn the handlebar to free the lock pin. Alternatively, the issue may be caused by a low battery. Please check if the battery power is sufficient.

When the steering lock fails to disengage, you have a 30-second window to operate the fuel tank lock and seat lock. During this time, briefly pressing the "⏻" button has no effect. To exit this mode, press and hold the "⏻" button, or wait for more than 30 seconds for the system to exit automatically.

## ⚠ DANGER

•When using non-induction or Bluetooth mode to force start, please be sure to turn the handlebar to the far left and confirm that the handlebar lock cylinder has been retracted before using the vehicle.

## ⚠ CAUTION

- If a short press of the '⏻' button does not produce any 'beep' sound, please check the battery level and fuses (main fuse, charging fuse, and PKE fuse) to ensure proper power supply.
- If a short press of the '⏻' button produces a 'beep' sound but the vehicle does not start, please check the key battery level and try using the non-inductive starting mode (refer to the instructions for non-inductive starting mode) or start the vehicle via mobile control.
- When the vehicle battery is depleted, be sure to fully charge it and unplug the charger before attempting to start.

## PKE power-off

After the motorcycle comes to a complete stop and the engine is off, turn the handlebar fully to the left. Press and hold the "⏻" button for more than 2 seconds, then release. The turn signals will flash twice, the steering lock will automatically engage, and a single "beep" will sound, indicating full power shutdown

## Passive Keyless Entry System

### CAUTION

•After power-off, verify the steering lock status. If the steering lock fails to engage, ensure the handlebar is turned fully to the left—the vehicle will automatically lock. If the handlebar is not turned fully left during shutdown, do not push the vehicle or coast, as sudden engagement of the steering lock when the handlebar moves left may cause a hazard. When pushing the vehicle or coasting downhill, ensure the PKE system is powered on (steering lock disengaged).

---

### CAUTION

•It is recommended to replace the key battery once a year.

•Vehicle should try not to be equipped with electronic devices that affect key signals, such as GPS, driving recorders, wireless chargers, etc.

•Keep the key away from interference sources such as mobile phones, power banks, and Bluetooth headphone charging cases; Try not to keep it with meal cards, NFC cards, car keys, metal pendants, etc. Do not wear protective cases made of metal, conductive or magnetic materials.

If there is a strong interference source near the vehicle affecting the key signal, the vehicle can be unlocked by emergency start method, mobile phone remote and Bluetooth control

---

## PKE fault prompt

When an abnormal condition is detected in the vehicle, the vehicle will alert the owner with a buzzer sound of varying lengths and a fault code, which means as follows:

Item	Alert Sound	Fault Code	Alarm Description
START button stuck	One long, two short	8002	If a button is detected as stuck after each startup, an alarm will sound once after 10 seconds.
Abnormal high-frequency reception	Two long, one short	8006	When abnormal high-frequency reception of the PKE main unit is detected upon every normal power-on startup, the alarm will trigger once (only a single alert; this item is not checked for non-powered inductive startup and APP remote startup).
No paired remote	Two long, three short	8008	If no paired remote control is detected when pressing the red startup button each time, an alarm will sound once.
Low battery in remote	Three long	8009	If an abnormal signal from the transponder battery is detected during each normal startup, an alarm will sound once (only once, non-electric induction startup and APP startup do not check this item).
Handlebar lock open abnormal	Five short	8010	If an abnormal unlock signal is detected during each startup, an alarm will sound once (only once)
Handlebar lock close abnormal	Five short	8011	If an abnormal lock signal is detected during each startup, an alarm will sound once(only once)

# Passive Keyless Entry System

Item	Alert Sound	Fault Code	Alarm Description
Abnormal low-frequency transmitting antenna	Three long and one short	8012	Each time an abnormal low-frequency transmitting antenna is detected during normal startup, an alarm will be triggered once (only once, not detected during power-off induction startup and APP startup)
Remote control out of detection area	Eight short	8014	After a normal startup, if the PKE main unit cannot receive the transponder response signal while operating, it will alarm and shutdown (non-electric induction startup and APP startup do not check this item)

# Instrument Panel

## Instrument panel mode selection

This instrument panel offers four theme modes that can be switched according to usage scenarios and personal preference. The following brief description uses the interface of Theme 2 as an example. Please note that as instrument functions are updated, content may change. Refer to your actual vehicle for the most current information.

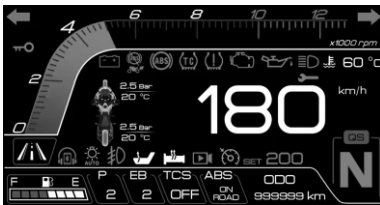

Theme 1



Theme 2

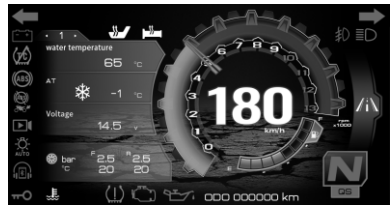

Theme 3



Theme 4(Screen projection mode)

## ⚠ WARNING









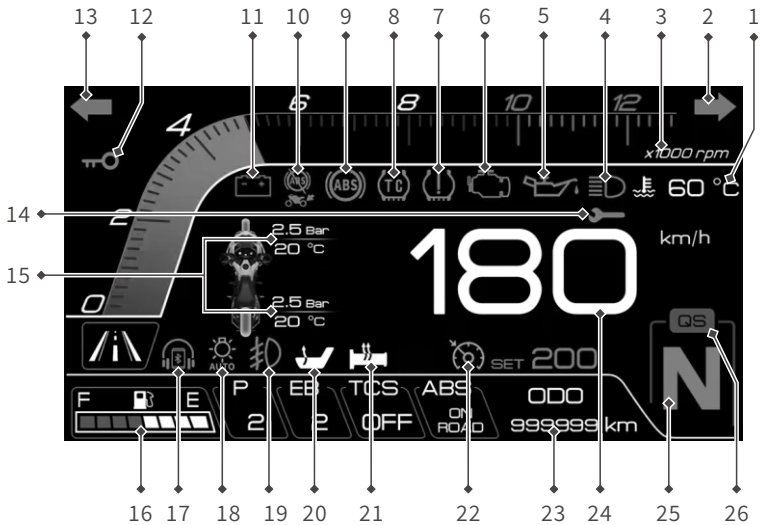











- Do not operate the instrument functions for extended periods while the engine is off, as this may drain or deplete the battery.
- Basic Operation: Use the left and right handlebar switches to operate and configure various instrument functions.
- It is not recommended to operate the instrument panel via the handlebar switches while the motorcycle is in motion.

# Instrument Panel

## Indicator and alarm lights

Instrument Panel



1. Coolant temperature warning light "  "
2. Right turn signal indicator "  "
3. Tachometer " x1000 rpm "
4. High beam indicator "  "
5. Engine oil pressure warning light "  "
6. EFI malfunction indicator light "  "
7. Tire pressure indicator "  "
8. TCS system warning light "  "
9. ABS system warning light "  "
10. Rear ABS off indicator "  "
11. Battery low voltage warning light "  "
12. Key ID indicator "  "
13. Left turn signal indicator "  "
14. Service/Maintenance reminder light "  "
15. Tire pressure , Tire temperature warning light "  $\frac{2.4 \text{ Bar}}{30^\circ \text{C}}$  "
16. Fuel gauge "  "
17. Phone bluetooth "  "
- Headset bluetooth "  "
18. Auto headlight "  "
19. Fog light indicator "  "
20. Seat heater indicator "  "
21. Heated grip indicator "  "
22. Cruise control indicator "  SET 200 "
23. Odometer " ODO: 999999 "
24. Speedometer
25. Gear position indicator
26. Quick shifter indicator " QS "

## Coolant temperature warning light



After power-on, the coolant temperature is displayed in real time. If the temperature reaches between 117°鉉 and 122°鉉, the warning light will activate, indicating that the cooling system requires inspection.

### Coolant temperature

Approximate range:

40°C to 122°C.

Below 40°C: Displays "—".

Between 117°C and 122°C: Coolant high-temperature warning light illuminates. Temperature value flashes.

Above 122°C:

Coolant high-temperature warning light illuminates. "122°C" flashes.

## Right turn signal indicator" ➡ "

This indicator flashes when the turn signal switch is engaged.

## Tachometer " x1000 rpm "

## High beam indicator" ≡ D "

This indicator illuminates when the high beam of the headlight is activated.

## Engine oil pressure warning



If engine oil pressure drops to a dangerous level while the engine is running, this warning light will illuminate. The light will also turn on when the ignition switch is set to "Ω" without the engine running.

### ⚠ WARNING

- If the oil pressure warning light illuminates while the engine is running, stop the engine immediately. Do not restart the engine until the issue is resolved.
- Operating the engine with the oil pressure warning light on may cause severe engine damage.

### ⚠ WARNING

- The oil pressure warning light should turn off shortly after the engine is started.
- If the oil pressure warning light remains on after starting the engine, stop the engine immediately and investigate the cause.
- Running the engine with low oil pressure will result in serious engine damage.

## EFI malfunction warning light " ⚠ "

After the engine starts successfully and operates normally, the EFI warning light should remain off. If the light illuminates during operation, it indicates a fault in the electronic fuel injection (EFI) system.

# Instrument Panel

## WARNING

• Continuing to ride the motorcycle with an active EFI system fault may cause damage to the motorcycle. Have the EFI system inspected by an authorized ZONTES flagship store or dealer.

## Tire pressure indicator " "

The indicator illuminates to alert when abnormal tire pressure or temperature is detected, requiring inspection and maintenance.

## WARNING

• If the TCS warning light does not turn off after the motorcycle speed reaches 5 km/h, or if it illuminates during riding, exercise extreme caution to prevent rear wheel skidding.

• If the warning light illuminates during riding, the TCS may be malfunctioning. Immediately seek repair at an authorized ZONTES flagship store or dealer.

## TCS system warning light " "

(Refer to the TCS section for details).

## WARNING

• If the TCS light does not turn off after the vehicle is powered on, or if the warning light illuminates while riding, pay special attention to avoid rear wheel skidding.

## CAUTION

• If the warning light does not function as described above, or if the warning light illuminates while riding, the TCS may be malfunctioning. Please promptly take the motorcycle to a ZONTES flagship store or authorized dealer for service.

## ABS system warning light " "

When the vehicle is powered back on, the ABS indicator light is on and would turn off when the vehicle reaches a speed of about 5km/h. If the lights are always on while driving: (please see pages 1-9 for details).

## Turn off the rear wheel ABS indicator " "

When the driving control-ABS function is set to "turn on the front wheels and turn off the rear wheels ABS", the indicator light comes on; restarting the vehicle will turn on the front and rear wheel ABS by default.

## WARNING

• If the ABS warning light does not turn off after the vehicle speed reaches 5 km/h, or if the warning light illuminates while riding, pay special attention to avoid wheel lock-up during emergency braking.

## CAUTION

• If the warning light does not function as described above, or if the warning light illuminates while riding, the ABS may be malfunctioning. Please promptly take the motorcycle to a ZONTES flagship store or authorized dealer for service.

## Battery low voltage warning light"

When the engine is off and the detected voltage is  $<12.5V$ , the symbol flashes as a warning (flash frequency 1 Hz; warning stops automatically when voltage  $\geq 12.5V$ ).

When the engine is running and the detected voltage is  $<13V$ , the symbol flashes as a warning (flash frequency 1 Hz; warning stops automatically when voltage  $\geq 13.0V$ ).

If battery voltage is  $\leq 13.3V$  at idle, idle speed will increase from 1350 rpm to 1550 rpm for charging. When battery voltage reaches  $\geq 14V$ , idle speed will return to 1350 rpm.

If the displayed voltage is greater than 15V, stop using the vehicle immediately and have the motorcycle inspected at a ZONTES flagship store or authorized dealer.

## Key ID indicator"

## Left turn signal indicator"

This indicator flashes when the turn signal switch is operated.

## Service/Maintenance reminder light



Refer to the periodic maintenance chart – engine oil.

## Tire pressure , Tire temperature warning light"

## Fuel gauge"

When only the first segment starts flashing, the remaining fuel is approximately 4.8L, and the low fuel warning indicator will also illuminate. When the fuel level indicator flashes, refuel as soon as possible.

## CAUTION

• When the fuel gauge segments scan up and down repeatedly, it indicates a broken or short circuit in the fuel level sensor wiring. Please have the vehicle serviced promptly.

The fuel level gauge will display accurately only when the vehicle is held upright in the normal riding position.

Rapid acceleration or deceleration, leaning the motorcycle, or riding on slopes may cause the fuel gauge indication to vary temporarily; this is normal.

# Instrument Panel

## Fog light indicator" "

The indicator lights up when the fog lights are turned on.

## Phone bluetooth" "

Lights up when connected to a phone via Bluetooth.

## Headset bluetooth" "

This indicator flashes when the turn signal switch is operated.

## Auto headlight" "

## Seat heater indicator" "

Briefly press the confirm button on the instrument panel main interface to switch to the seat heater icon. Press the ↑ button to turn on the seat heater function; pressing ↑ increases the heat level, while ↓ decreases it (Levels 1–3, Level 0 is off). You can activate this function in advance; it will operate when engine speed is >2000 rpm and battery voltage is >13.5V. The function will turn off if voltage drops below 12.8V or if the engine speed condition is not met.

When the seat heater is turned on, if the corresponding icon on the main interface turns red, it indicates a fault preventing normal operation. Go to the instrument main menu – Vehicle Information – Fault Information page to check the corresponding fault code for troubleshooting.

## WARNING

- When the seat heater is turned on (Levels 1–3), the corresponding indicator light will illuminate. Level 0 is the off position.
- The seat heater includes an idle protection feature; heating will only occur while the vehicle is in motion.
- Do not use the seat heater in hot weather.
- If the seat is damaged, replace the seat before using the seat heater.

## Heated grip indicator" "

On the instrument panel main interface, briefly press the OK button to switch to the heated grips icon. Press the  $\uparrow$  button to turn on the heated grips; pressing  $\uparrow$  increases the heat level, while  $\downarrow$  decreases it (Levels 1–3, Level 0 is off). You can activate this function in advance; it will operate normally when engine speed is  $>1300$  rpm and battery voltage is  $>13.5V$ . The function will turn off if voltage drops below 12.8V or if the engine speed condition is not met. If the heated grips icon turns red under any circumstances, check the vehicle's overall voltage and whether the intelligent control unit is functioning properly.

When the heated grips are turned on, if the corresponding icon on the main interface turns red, it indicates a fault preventing normal operation. Go to the instrument main menu – Vehicle Information – Fault Information page to check the corresponding fault code for troubleshooting.



## Cruise control indicator" SET 200"

The cruise control function helps riders maintain a constant speed during long-distance riding, reducing fatigue. Control switches: the system consists of the "RES+/SET-" buttons.

### Conditions for use:

1. Vehicle speed is between 45–160 km/h.
2. Gear position is between 3–6.

**Safety status:** Ensure the side stand is retracted, the motorcycle tilt angle is normal, and no fault codes are displayed.

**Activating the system:** After powering on, briefly press the "SET-" button; the cruise control symbol "  " on the instrument panel will illuminate, indicating cruise standby mode. When the speed and gear conditions are met, press the SET/- button again briefly to activate cruise control. The cruise control indicator and the target cruise speed "  SET 200 " will light up, indicating cruise active mode. The cruise speed will be set to the current riding speed.

### Adjusting speed:

**Accelerate:** Briefly press the "+" button to increase speed by 1 km/h each time; hold to accelerate continuously.

**Decelerate:** Briefly press the "SET-" button to decrease speed by 1 km/h each time; hold to decelerate continuously.

You can manually operate the throttle to increase riding speed. After accelerating to the desired speed, briefly press the "SET-" button to set the cruise speed to the current riding speed. If a new speed is not set, releasing the throttle will cause the speed to return to the previously set cruise speed.

# Instrument Panel

## Temporary deactivation:

1. Operating the front or rear brake
  2. Operating the clutch
  3. Operating the gear shift lever
  4. Inability to maintain the set cruise speed for an extended period
  5. Activation of ABS or TCS function
- The cruise control set indicator (the word "SET") and the target cruise speed will turn off, while the cruise control symbol remains illuminated (yellow).

## Resuming cruise control:

1. If the speed is still above 45 km/h, briefly press the "SET/-" button. The cruise speed will be set to the current riding speed.
2. Use the throttle to accelerate to the desired speed, then briefly press "SET/-". The cruise speed will be set to the current riding speed.
3. If the speed is still above 45 km/h, briefly press "RES/+". The riding speed will return to the previously set cruise speed.
4. If the speed is below 45 km/h, use the throttle to increase speed to 45 km/h, then briefly press "RES/+". The riding speed will return to the previously set cruise speed.

## Deactivating cruise control:

Turning off the ignition completely exits cruise control; both the cruise control symbol and the "SET" indicator will turn off.

## Cruise control will be automatically deactivated under the following conditions:

1. Inability to maintain the set speed (e.g., on steep slopes).
2. Detection of wheel slip or spin (if TCS is enabled, traction control will engage).
3. Engine stop switch is in the "OFF" position.
4. Engine stalls.
5. Side stand is deployed. If cruise control deactivates automatically, the system indicators will turn off.

## Usage restrictions:

1. Avoid use on curves, slippery roads, congested areas, or complex traffic conditions.
2. Avoid low-traction surfaces (e.g. gravel, wet roads).
3. Unsuitable for congested roads or frequent lane changes.

## CAUTION

- Keep both hands on the handlebars while using cruise control, and be prepared to takeover control at any time.
  - Braking will immediately deactivate cruise control. Prioritize braking safety.
  - TCS intervention will deactivate cruise control.
-

## Cruise control usage recommendations:

If the target speed is within 10 km/h of the current cruise speed, briefly press the "+" or "SET/-" button to adjust incrementally.

Example: At a current cruise speed of 100 km/h, to set 105 km/h, press "+" 5 times (Note: Avoid excessively rapid presses, as the ECU may not register them).

If the target speed exceeds 10 km/h above the current cruise speed, manually accelerate to the target speed first, then press "SET/-" to set the new cruise speed. Example: To increase from 100 km/h to 120km/h, manually throttle to 120km/h, press "SET/-" once, and fine-tune with "+" or "SET/-" if needed. Note: During active cruise control (when both cruise indicators "Ⓢ" and "SET" are lit), manually exceeding 140 km/h and pressing "SET" will not register.

**Overtaking Scenario:** While cruising at 100 km/h, manually throttle to accelerate past slower motorcycles. After overtaking, release the throttle—the speed will gradually return to 100 km/h.

**Setting Maximum Speed (140 km/h):** Ensure the cruise indicator "Ⓢ" is orange. Manually accelerate to  $\geq 40$  km/h, then press "SET/-" to activate cruise control. The speed will automatically stabilize at 140 km/h.

## Odometer" 000.999999"

Total driving mileage

## Speedometer

### Gear position indicator

This vehicle adopts an international gear arrangement, equipped with 6 gears and one neutral gear.

### Quick shifter indicator" Ⓢ "

# Instrument Panel

## Indicator and alarm light

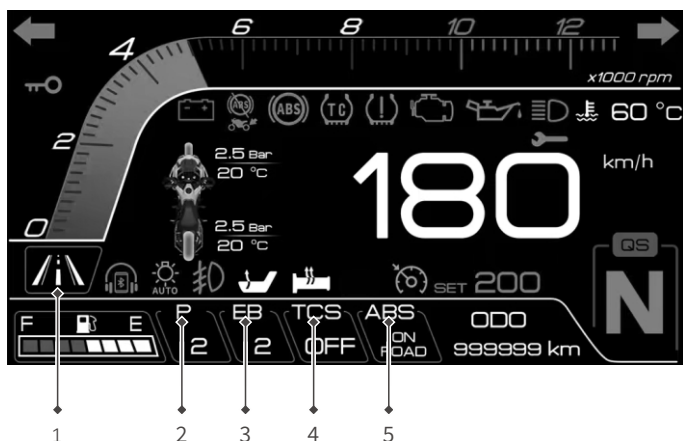

1. Riding mode
2. P (Power)
3. EB (Engine brake)
4. TCS level
5. ABS mode

### Riding mode

Press the M button on the right handlebar briefly to cycle through riding modes without boundary. Modes include: SPORT, ROAD (factory default), RAIN, OFF ROAD, and RIDER. Riding mode cannot be switched when ABS or TCS reports a fault. To restore switching capability, turn the motorcycle power off and on again, then ride at a speed above 5 km/h until the ABS system completes self-diagnosis and both "(ABS)" and "(TCS)" indicators turn off. Riding mode can then be switched.

### P(Power)

P stands for Power. The lower the value, the stronger the power and the quicker the throttle response (range 1–4). Factory default is 3.

### EB(Engine brake)

EB stands for Engine Brake. The lower the number, the weaker the engine braking effect (range 1–3). The EB value is not selectable independently; it follows the P value. Factory default is 2.

### TCS level

TCS has different levels corresponding to each riding mode:

- SPORT – Level 3
- ROAD (factory default) – Level 5
- RAIN – Level 7
- OFF ROAD – Level 1
- RIDER – Level 1
- OFF means TCS is disabled.

## Rear ABS off indicator" "

When the driving control setting "Disable Rear ABS" is set to "OFF," this indicator illuminates. Restarting the vehicle restores the default setting with both front and rear ABS enabled.

## WARNING

•If the ABS warning light does not turn off after the vehicle speed reaches 5 km/h, or if the warning light illuminates while riding, pay special attention to avoid wheel lock-up during emergency braking.

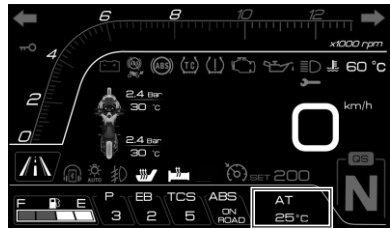

## Ambient temperature

1. Display range: -15°C to 50°C.
2. Below -15°C displays "--".
3. Above 50°C turns red and flashes at 1Hz as a warning.
4. Ice symbol illuminates at 3°C and below, turns off at 5°C and above.
5. At speeds below 30km/h, heat radiated from the road and exhaust from other vehicles may affect temperature readings.

# Instrument Panel

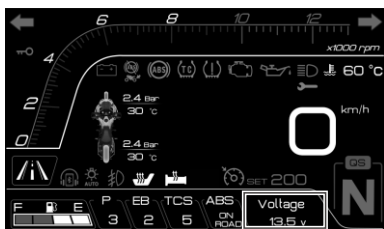

## Voltage

When the engine is off and detected voltage is  $<12.5V$ , the symbol flashes as a warning (flash frequency 1Hz; warning stops automatically when voltage  $\geq 12.5V$ ).

When the engine is running and detected voltage is  $<13V$ , the symbol flashes as a warning (flash frequency 1Hz; warning stops automatically when voltage  $\geq 13.0V$ ).

If displayed voltage exceeds 15V, stop using the vehicle immediately and have it inspected at a ZONTES flagship store or authorized dealer.

If battery voltage is  $\leq 13.3V$  at idle, idle speed increases from 1350rpm to 1550rpm for charging. Once battery voltage reaches  $\geq 14V$ , idle speed returns to 1350rpm.



## Trip meter

Range: 0-9999.9 km (resets to zero after exceeding the maximum value).

To reset: On the trip meter interface, press and hold the left button for 2 seconds to clear the trip meter, average speed, and average fuel consumption.

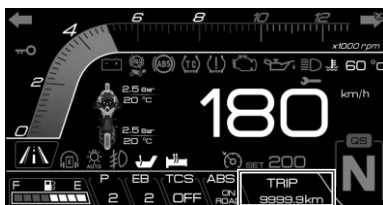

## Total mileage



## Average fuel consumption

Shows average fuel consumption since the last trip meter reset. Calculation is based on values recorded on the trip meter.

Display range: 0.0-99.9 L/100 km. When average fuel consumption is reset, "--" is displayed.

# Instrument Panel

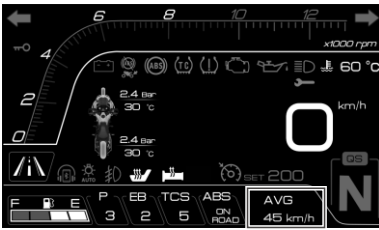

## Average speed

Displays the average speed since the trip meter was last reset. The average speed is calculated based on the values recorded on the trip meter. Display range: 0.0–199.9 km/h. When the average speed is reset, “-.” is displayed.

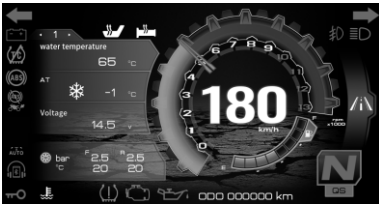

When "Theme 3" is selected, the instrument panel will display altitude information.

## Altitude

(Displayed only in Theme 3): Display range: -999 m to 9999 m. Values beyond this range will show the boundary limits. After replacing the instrument panel or restarting the motorcycle power, the altitude value will gradually calibrate during riding. Calibration time may vary depending on GPS signal strength. Fluctuations in altitude values during calibration are normal.

## Quick menu

Press the “OK” button on the left handlebar switch briefly to enter the quick function menu. Use the left/right buttons to switch between function options, and the up/down buttons to change levels. Press the OK button again briefly to exit.



## ABS mode

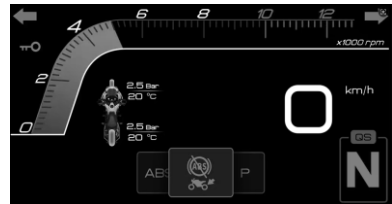

## Rear ABS off indicator

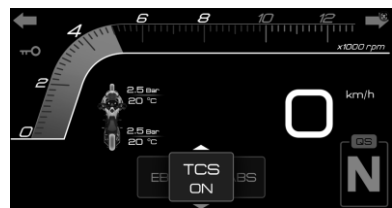

## TCS level

# Instrument Panel

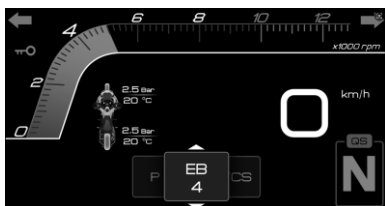

EB (Engine Brake)

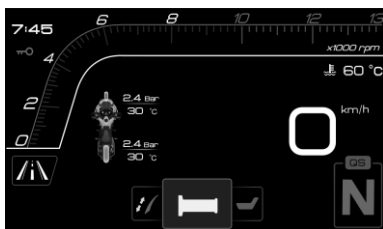

Handlebar



P (Power)



Settings

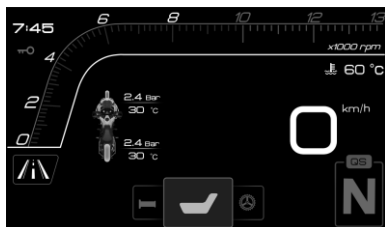

Seat



Windshield adjustment

## Menu structure

Home Screen	Quick Menu							
	Windshield Control	Raise						
		Lower						
	Heated Grips	3						
		2						
		1						
		OFF						
	Seat Heating	3						
		2						
		1						
		OFF						
	Settings (Entry option: Function Settings)	Level 1 Menu		Level 2 Menu	Level 3 Menu			
		Display (Entry: Main Window)		Style (Default: Style 3)	2(Purple)			
					1 (Yellow)			
					3 (Orange)			
				Backlight (Default: Level 5)		5		
						4		
						3		
						2		
						1		
Date (Default: Manual)				Manual Standard				
				Auto Standard				
Language (Default: Chinese)		Chinese						
		English						
Theme (Default: Theme 2)		3(Wild)						
		2(New Theme)						
		1(Classic)						
Units (Default: Metric)		Metric						
		Imperial						
Riding Control (Entry: Rear ABS)		Rear Wheel (Entry: ON)	OFF					
			ON					

# Instrument Panel

Home Screen	Settings (Entry option: Function Settings)	Level 1 Menu	Level 2 Menu	Level 3 Menu	
		Function Settings (Entry: Tire Pressure Settings)	Tire Pressure Settings(Entry option: Tire Pressure Detection)	Rear Wheel	Not Learned / Learning / Learned
				Front Wheel	
				Tire Pressure Detection (Default: ON)	ON
					OFF
				Units (Default: bar)	kpa
					bar
					psi
		Bluetooth (Entry option: Bluetooth On/Off)	Bluetooth Connection		
			Bluetooth On/Off		
			Clear Connection		
		Vehicle Information (Entry option: Fault Information)	Maintenance Reminder	Reset (Entry option: No)	否
					是
Fault Information					
Version Information					

On the home screen, briefly press the OK button to access the quick menu. Press and hold the OK button to enter the main menu. The system will automatically exit if no operation is performed within 10 seconds. Use left/right buttons to switch between options, and up/down buttons to adjust settings. Briefly press the OK button to exit.

The last item in the quick menu is the main menu. Briefly press the OK button to enter. Use up/down buttons to navigate, press OK to confirm, left button to return to the previous level, and right button to proceed to the next level. All options have boundary limits.

On any interface, push the control lever to the left and hold for 1.5 seconds to directly return to the home screen. Alternatively, the system will automatically return to the home screen after 30 seconds of inactivity (exceptions: camera front/rear view interfaces and vehicle information interface).

## Heated Grip Fault Codes

Code	Fault Description
0000	Seat Heating Failure
0100	Seat Heating Failure
9092	Heated Grip Failure
9093	Heated Grip Failure

## Clock settings

Online Calibration: Time is automatically synchronized with GPS upon each power-on. The year, month, day, hour, and minute can also be manually set based on local time.

Operation: Enter manual settings and configure in the order of "Year," "Month," "Day," "Hour," and "Minute." When the cursor selects a field, use the up/down buttons to adjust the value. Briefly press the left/right button to confirm and switch to the next field

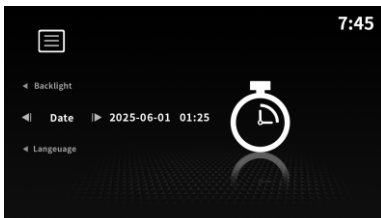
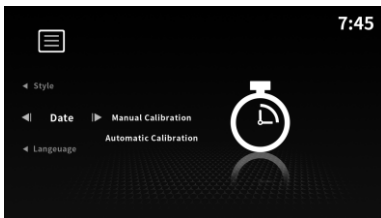

## Bluetooth settings

Pairing: Before two Bluetooth devices can establish a connection, they must recognize each other. This mutual recognition process is called pairing. Once recognized, devices are stored and only need to be paired during initial contact. Prerequisites for Pairing: The Bluetooth function of the devices must be enabled, and the devices must be set to discoverable. For initial pairing with a mobile phone, the phone must be in the Bluetooth interface to be recognized and paired by the instrument panel.

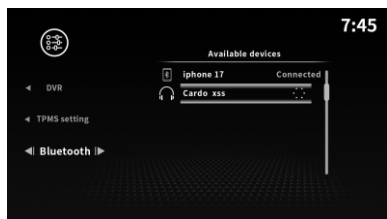
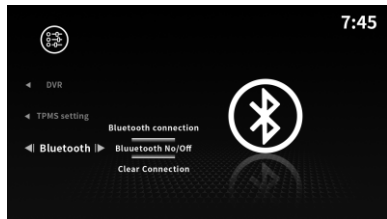

# Instrument Panel

## Unit settings

Switch between metric or imperial units to suit your reading preferences.



## Language settings

Change the system language.

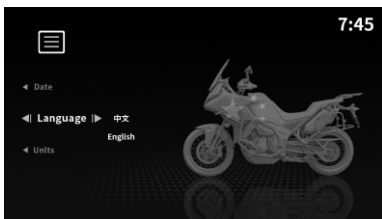

## Backlight settings

Choose from 5 backlight brightness levels or select auto-adjustment (brightness adjusts automatically based on the photoelectric sensor)

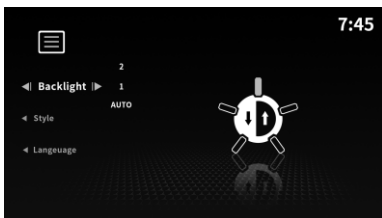

## Vehicle Information

Displays fault information for the ECU, PKE, ABS, MCM, and tire pressure systems.



## GPS indicator "GPS"

Green: Indicates strong positioning signal, and the vehicle can be located normally.

Yellow: Indicates moderate positioning signal, and the location may deviate.

Red: Indicates poor positioning signal, and the vehicle cannot be located.

## 4G signal indicator "4G"

Shows 4G signal strength. The icon fills up as signal quality improves.

## Key number "Key"

This indicates the number of the key currently in use, which corresponds one-to-one with the key codes in the ZONTES Smart APP. For example: Key 1 corresponds to the [0] key code in the APP, Key 2 corresponds to the [1] key code in the APP, and so on. Each vehicle can have a maximum of 4 keys.

## Maintenance information

You can view the remaining maintenance mileage in the motorcycle information section. In the remaining maintenance mileage option, briefly press the "OK button" to reset and proceed to the next maintenance cycle.

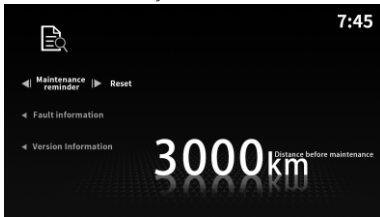

## Tire pressure information

When the tire pressure monitoring setting is enabled, the tire pressure and temperature will display "--" each time the motorcycle is powered on. Actual tire pressure values are transmitted only after the first time exceeding the minimum speed of 30 km/h (TPMS sensors send signals to the motorcycle only after exceeding the minimum speed).

Tire Pressure Unit Settings: Briefly press the "Up" or "Down" button on the 5-way switch to toggle units, and press the OK button to confirm.

Tire Pressure Learning:

Rotate the valve stem of the front (or rear) wheel to the 12 o'clock position and let the motorcycle stand for over 5 minutes. Operate the instrument panel to enter tire pressure learning mode: Power on the instrument panel → Enter the menu → Tire pressure settings interface → Select front/rear wheel → Set the front/rear wheel to "Learning" status.

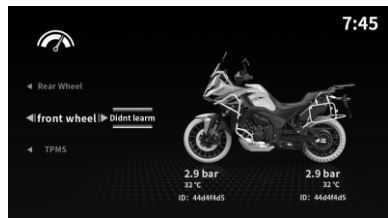
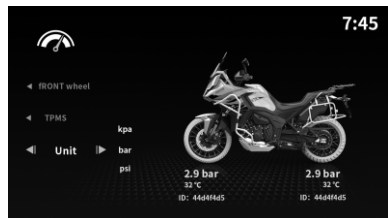
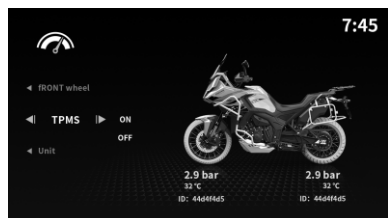

# Maintenance

## First maintenance

The initial 1,000 km maintenance is mandatory to ensure the motorcycle remains in the safest and most efficient condition. It is the owner/rider's responsibility to ensure safety.

### WARNING

- Failure to perform proper maintenance or address malfunctions before riding may lead to serious or fatal accidents.
- Always follow the inspection, maintenance recommendations, and service intervals provided in this Owner's Manual.
- If unfamiliar with motorcycle maintenance, entrust the service to an authorized ZONTES dealer.

## Maintenance safety

Read the maintenance instructions before each service to ensure you have the necessary tools, parts, and skills. We cannot anticipate every hazard that may arise during maintenance. Only you can decide whether to perform the service.

## Follow these guidelines during maintenance:

- Turn off the engine and remove the key.
- Place the motorcycle on a stable, flat surface using the side stand or support it with the main stand.
- Allow the engine, muffler, brakes, and other high-temperature components to cool before starting work to avoid burns.
- Start the engine only under specified conditions and in a well-ventilated area.

### WARNING

- Brake discs, calipers, and pads may become extremely hot during use. To avoid potential burns, allow brake components to cool before touching them.

## Initial routine inspection

The first inspection at 1,000 km is critical. During this period, all engine components have undergone break-in. This service involves readjusting components, tightening all fasteners, and replacing engine oil contaminated by wear debris. Thoroughly performing this initial 1,000 km service ensures optimal performance and extends your motorcycle's service life.

## CAUTION

Ensure all periodic maintenance tasks are strictly performed as specified in this manual. The initial 1,000 km service must follow the methods described in this section. Pay special attention to "DANGER" and "WARNING" notices in this section. Using non-genuine replacement parts may accelerate wear and shorten the motorcycle's lifespan. Always choose genuine ZONTES parts for replacements.

- Dispose of waste generated during maintenance (e.g., cleaners, used oil) properly to avoid environmental contamination.
- The maintenance chart specifies the minimum required services. If your motorcycle is frequently used under severe conditions, perform maintenance more frequently than indicated. Consult an authorized ZONTES service center if you have questions about maintenance intervals.

## Regular maintenance table

① Inspect (clean, lubricate, adjust or replace if necessary) Ⓡ:Replace Ⓣ:Tightening★:Note

Item	Pre-ride check	Frequency*1						Annual check	Remake	Refere page number
		X1000km	1	5	10	15	20			
Secondary water tank level	①	①	①	①	①	①	①	Replace every 3 years or 30000 kilometers	6-20	
Brake pad wear	①		①	①	①	①	①	Check wear condition	-	
Rear swingarm anti-wear block	①	①	①	①	①	①	①	Replace after 30000 kilometers ★ Note 1	-	
Fuel level		①							-	
Engine oil	☆	①	Ⓡ	Ⓡ	Ⓡ	Ⓡ	Ⓡ		6-16	
Oil filter	☆		Ⓡ	Ⓡ	Ⓡ	Ⓡ	Ⓡ		6-17	
Air filter (element)	☆☆☆		①	Ⓡ	①	Ⓡ	Ⓡ	★ Note 2	6-22	
Tire	☆☆	①	①	①	①	①	①	Check tire pressure and tread wear	6-40	
Brake fluid	☆☆	①	①	①	①	①	①	Replace every 2 years	6-42	
Drive chain	☆☆	①	①	①	①	①	①	★ Note 1	-	
Wheel spokes	☆☆☆	①	①	①	①	①	①	Check for looseness or detachment	-	
Front suspension	☆☆☆	①	①	①	①	①	Ⓡ	★ Note 3	6-30	
Rear suspension	☆☆☆	①	①	①	①	①	①	Check for leaks	6-31	
Brake system	☆☆☆	①					①	Check fluid level in reservoir	-	
Radiator hoses			①	①	①	①	①		-	
Air filter oil drain tube			①	①	①	①	①		6-24	
Electronic seat cushion lock, Electronic fuel tank lock								Clean and lubricate every 4,000 km	-	

## Regular maintenance table

① Inspect (clean, lubricate, adjust or replace if necessary) ② Replace ③ Tightening ★ Note

Item	Pre-ride check	Frequency*1						Annual check	Remarks	Reference page number
		X1000km	1	5	10	15	20			
Idle speed				①	①			Start check	-	
Fuel lines				①				Check for leaks	-	
Muffler	☆			①	①	①	①	★ Note4 Figure 1	-	
Clutch lever free play	☆			①	①	①	①	Follow the operation video	6-26	
Internal mechanism of steering lock	☆				①		①	★ Notes5	-	
Bolts and nuts in steering mechanisms	☆			①	①	①	①	Figure 2	-	
Steering mechanism bearings	☆	☆					①	Replenish grease every 15,000 km	-	
Vehicle fasteners, bolts, nuts	☆	☆		①	①	①	①	Figure 2	-	
Wheel and sprocket carrier bushings and oil seals	☆	☆		①	①	①	①	★ Note6	-	
Brake hoses	☆	☆		①	①	①	①	Check for leaks	-	
Spark plug	☆	☆			①		①		6-15	
Windshield assembly	☆	☆			①			★ Note7	6-12	
Swingarm needle bearings	☆	☆					①	Replenish grease every 15,000 km	-	
Multi-Link suspension needle bearings	☆	☆					①	Replenish grease every 15,000 km	-	
Valve clearance	☆	☆					①	Inspect and adjust every 40000 km	-	
								★ Note8	-	

# Maintenance

★ : This service should be provided by a dealer or qualified service center. Owners may perform it themselves if they possess suitable tools, service information, and mechanical understanding.

★ ★ : For safety reasons, this item must be serviced by a dealer or qualified service center.

★ Note 1: Clean and lubricate the chain every 500–1000 km, and inspect the wear condition of the upper and lower swingarm chain protectors.

★ Note 2: If riding in particularly humid or dusty areas, perform maintenance more frequently.

★ Note 3: Service the suspension every 20,000 km (12,000 miles) by replacing oil seals, dust seals, and suspension fluid.

★ Note 4: If the motorcycle falls over or the muffler/heat shield is impacted or scraped by external force, first carefully inspect the appearance, mounting point integrity, and whether the muffler mounting rubber is deformed. After starting the engine, check for exhaust leaks. Internal rattling or severe external damage usually requires replacement. All related hangers, brackets, mounting rubbers, and bolts must be replaced before continuing to ride.

Note 5: Every 10,000 km (6,000 miles), inspect, clean, and lubricate. Refer to the official website's "Steering Lock Maintenance Video" for detailed procedures

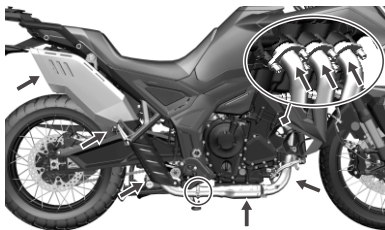

Figure 1

★ Note 6: Check the wear condition of the oil seal lip. Replenish grease if necessary.

★ Note 7: Every 5,000 km (3,000 miles), check the windshield raising/lowering function; check for binding/dry grinding or abnormal noise in the windshield support; check the guide rails for excessive dust and debris, and promptly clean them and apply dedicated lubricating grease.

★ Note 8: Valve clearance (engine cold state):  
Intake: 0.1–0.22 mm.  
Exhaust: 0.2–0.33 mm.

Check the following for looseness: Front disc brake caliper bolts, Front fork lower tube bolts, Upper and lower triple clamp bolts, Upper triple clamp decorative nuts, Disc brake rotor and rear disc brake caliper bolts, Rear axle nut, Rear swingarm nuts, Side stand cut-off switch bolts. Also check that the retaining rings on both sides of the main stand are present and intact.



Figure 2

# Maintenance

## Pre-drive inspection

Failure to thoroughly inspect the motorcycle before riding or to maintain it properly may increase the risk of accidents and damage. Always inspect the motorcycle before each use to ensure it is safe to operate. Refer to the "Maintenance" section of this Owner's Manual for details.

## Before riding, perform the following checks:

### Steering system

- Steering moves smoothly and freely
- No obstructions to movement
- No looseness or play

### Throttle

- Operation is smooth, and throttle returns freely

### Muffler

- Do not remove the muffler end cap. Doing so will alter the vehicle's power characteristics, affect engine performance and durability, and increase riding noise. Removal is prohibited.

## Brakes

- The brake lever and brake pedal operate normally.
- Brake fluid is above the lower level mark in the reservoir.
- There is no "spongy" feeling indicating poor braking.
- There is no dragging (brake drag).
- There are no brake fluid leaks.
- Brake disc/pad wear must not exceed the specified limit.

## Shock absorbers

- No foreign objects attached, no oil leaks, and smooth operation.

## Fuel

- Sufficient fuel for the planned journey.

## Engine oil

- **Check whether the oil level is sufficient. Following steps 6-17, the oil level should be between the upper and lower marks on the oil sight glass.**

## Lights

- Ensure the following lights function properly: headlight, taillight/brake light, instrument panel lights, turn signals, front position lights, and license plate light.

## Indicator lights

- Ensure the high beam indicator and turn signal indicators illuminate correctly.

## Horn

- Functioning normally

## Brake switch

- Functioning normally.

## Engine stop switch

- Functioning operation.

## Side stand/ignition interlock switch

- Functioning operation

### CAUTION

- Failure to familiarize yourself with the controls may lead to loss of vehicle control, resulting in accidents or injuries.
- Read the Owner's Manual carefully to understand all controls. If any control or function is unclear, consult a ZONTES dealer.

### WARNING

- Installing non-genuine ZONTES parts may compromise the safety of your motorcycle and could lead to accidents resulting in injury or even death.
- Always use genuine ZONTES original parts or certified alternatives designed and approved for your motorcycle.

## Battery removal

The battery is located under the rider's seat. To remove the battery, proceed as follows:

1. Open the seat and turn off the motorcycle's power switch.
2. Remove the seat and unbuckle the battery strap.
3. Pull back the black protective cap and disconnect the negative (-) terminal, then pull back the red protective cap and disconnect the positive (+) terminal.

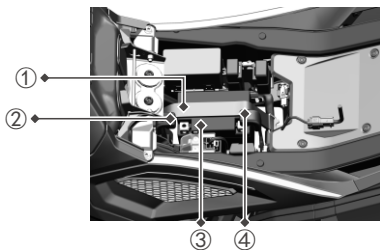

- ① Battery strap
- ② Battery positive cable (red)
- ③ Battery
- ④ Battery negative cable (black)

### ⚠ CAUTION

•When reinstalling the battery after removal, ensure the surrounding wiring harness is properly routed. Pay special attention to the positive terminal area and other red wires to avoid contact with the frame or other metal parts. The battery must be fully seated inside the battery box.

•After reinstalling the battery, if the vehicle loses power during starting or riding, the battery wakes from sleep mode, idle speed is abnormal, or fuses have been reinserted, perform an individual EFI hardware reset as follows: Turn on the ignition switch and the engine stop switch, pull in the clutch lever, start the engine and let it idle for 60 seconds, then turn off the engine stop switch. Wait 10 seconds and repeat the procedure.

## New battery activation

Battery installation:

1. Before installing the battery, inspect its appearance. The case should be free of dents or cracks, the cover should be well sealed with no signs of leakage, and the terminals should be free from tilt or deformation.
2. First connect the positive (+) cable (red wire), then connect the negative (-) cable. Caution: Do not reverse the polarity, as this may damage the voltage regulator/rectifier and other electrical components.
3. After tightening the bolts, apply grease or petroleum jelly to the bolts, nuts, and terminals to prevent corrosion that could cause poor contact.
4. Place the battery into the battery box and secure it with the strap. Ensure the battery does not shake.

## Chargingport

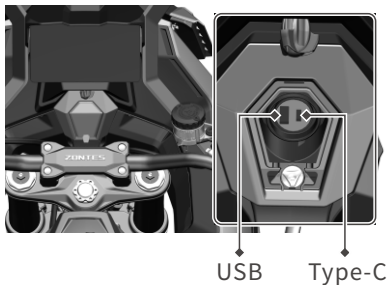

### Battery charging instructions

If the battery is discharged and cannot start the vehicle due to prolonged storage or other reasons, recharge the battery as follows:

1. Open the dust cap of the vehicle's charging port.
2. Use a charger or power bank and connect it to the Type C charging port for charging.

### ⚠ CAUTION

- The USB port cannot be used to charge the battery in reverse; only the Type-C port can charge the battery.
- When using a charger or power bank to charge the vehicle battery via the Type-C port, note that the maximum charging power is 30W. It supports AFC/FCP/PD2.0/PD3.0 charging protocols.

### Battery cleaning

1. Remove the battery.
2. If the terminals show initial corrosion with white deposits, clean them with warm water and dry thoroughly.
3. If the terminals are severely corroded, use a wire brush or sandpaper to clean and polish them. Wear safety glasses during this process.

### Battery replacement

When replacing the battery, ensure the new battery model matches the original specifications. The battery specifications are designed to be compatible with the motorcycle's electrical system. Using an incorrect battery model may compromise performance, reduce lifespan, and potentially cause electrical failures.

### Use and maintenance

1. Do not crank the engine for more than 5 seconds per starting attempt. If the engine fails to start after several attempts, inspect the fuel supply system and the starting/ignition systems.
2. The following conditions may cause battery over-discharge or insufficient charging, shortening its service life:
  - Frequent starting attempts
  - Short riding durations or distances
  - Extended periods of ignition-on without engine operation
  - Installation of additional electrical accessories (e.g., high-power lights, audio systems, GPS)

3.If abnormal symptoms occur (e.g., sluggish starter motor, dim lights, weak horn sound, or instrument panel blackout/restart during ignition), recharge the battery immediately.

4.If the motorcycle will be unused for an extended period, either remove the battery for separate storage or disconnect its terminals. Fully charge the battery before storage and recharge it every three months.

5.Charging Precautions:

- When charging, use a charger or power bank connected to the Type-C charging port, or remove the battery and charge it separately using a dedicated battery charger.
- Avoid overcharging, as it may cause electrolyte leakage, swelling, or even explosion, posing serious hazards.

## CAUTION

1. Do not attempt to open or modify the battery in any way.
- 2.Avoid using or storing the battery near high temperatures or open flames, as this may cause damage to the battery and vehicle.
- 3.Do not reverse the positive and negative terminals during installation, as this may damage the battery and vehicle.
- 4.Use the provided screws and nuts to securely connect the battery terminals. Loose connections may cause damage to the battery and vehicle.

5.If any abnormal conditions are detected during use or charging (e.g., unusual odor, overheating, deformation, discoloration, or other irregularities), stop use immediately and remove the battery from the vehicle.

6.This battery is standard equipment for the motorcycle and should not be used for purposes other than starting the motorcycle.

7.Installing additional devices such as anti-theft systems, GPS, or fog lights may impact the battery and electrical system. Use only qualified branded products and connect them to the reserved interfaces provided by the manufacturer. Do not modify wiring privately, as this may cause electrical system malfunctions or excessive battery discharge.

8.Do not damage the battery. The electrolyte inside is harmful to skin and eyes. Avoid contact with skin, eyes, or clothing. If contact occurs, rinse immediately with plenty of water and seek medical attention.

---

## Tool kit

Press the "SEAT" button on the left handlebar briefly to open the seat, then open the storage cover of the battery box to access the tool kit.



## Left and right fairings(quick release)

The left and right fairings are quick-release components. Release the clips at the top and bottom of the fairing (bottom first, then top), then push the fairing toward the rear of the vehicle to remove it.

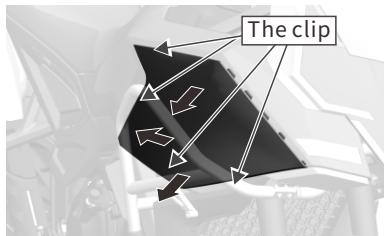

There are clips on all four sides indicated by the arrows. First release the lower clip, then release the remaining three clips in order. Finally, pull the panel outward diagonally in the direction of the arrow to complete removal.

## Head cowl panel (quick release)

The head cowl panel is a quick-release component. ① First, use a flat-head screwdriver to pry open the mushroom pins in the direction of removal. ② Then, use a plastic trim tool to disengage the clips, and pull the remaining clips in the removal direction to complete the detachment.

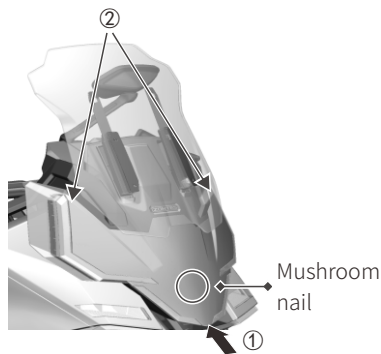

# Maintenance

## Windshield assembly maintenance

Check the windshield raise/lower function every 5,000 km:

- Check for binding, dry rubbing, or abnormal noise during windshield operation.
- Check the guide rails for excessive dust or debris, and clean them promptly while applying grease.
- Grease specification: PI-SAM 371C.

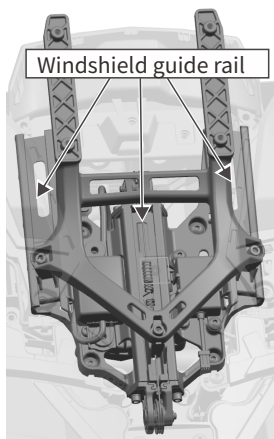

## Engine guard removal

1. Deploy the main stand to stabilize the motorcycle. If the motorcycle has been started recently, allow it to cool down for a while before proceeding.

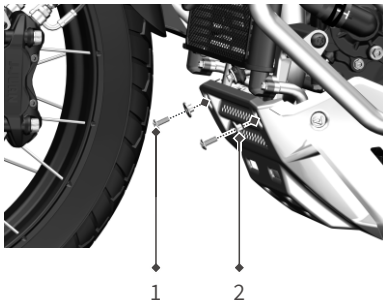

1. M6×16 bolt
2. Flanged bushing

2. Use a T25 torx wrench to remove the two M6×6 bolts (1) at the front of the engine guard, and remove the flanged bushings (2).



3. Use a T25 torx wrench to remove the three bolts (1) and flanged bushings (2) securing the engine guard, then remove the engine guard.

## Muffler

### Muffler maintenance

This motorcycle's muffler is equipped with a catalytic converter to effectively reduce the emission of harmful substances during operation. To ensure its optimal performance, refer to the scheduled maintenance chart in the "Maintenance" section.

To extend the muffler's service life and prevent issues such as corrosion or reduced catalytic efficiency due to improper use or maintenance.

#### Strictly adhere to the following guidelines:

- Do not rev the engine at high speeds while stationary for extended periods.
- Avoid prolonged low-speed riding under heavy loads.
- Do not add anti-rust oil or engine oil into the muffler.
- Never spray cold water directly onto the muffler while the engine is hot.
- Avoid coasting with the engine off.
- Do not use low-quality engine oil.
- Use only unleaded gasoline.
- Promptly remove dirt and debris from the muffler surface and tailpipe.
- Maintain the engine in good working condition through regular maintenance and inspections. Prevent poor combustion that may cause exhaust gases to reignite inside the pipe, leading to catalytic converter sintering and failure.
- When installing the muffler, ensure the sealing gasket is properly positioned.
- When installing the muffler decorative cover, attach heat insulation pads at all screw points to prevent heat damage or fire hazards from high temperatures.

# Maintenance

## Spark plug

### Spark plug inspection

Spark plugs are critical components. As specified in the maintenance schedule, they should be regularly removed and inspected. The condition of the spark plugs reflects the engine's operating status. The ceramic insulator around the center electrode should appear light brown (the ideal color under normal riding conditions). If the spark plug shows significantly different coloration, it may indicate poor engine performance.

If the electrodes show corrosion, excessive carbon deposits, or other buildup, replace the spark plugs promptly.

### ZONTES specified spark plug

TORCH/BN8RTIP-8

### Spark plug replacement

1. Use a stiff wire or needle to remove carbon deposits from the spark plug. Then adjust the electrode gap to 0.7–0.9 mm using a feeler gauge.
2. While cleaning, observe the coloration at the spark plug tip. This indicates whether the standard spark plug is suitable. A normally used spark plug should have a light brown ignition zone. If the insulator appears whitish and the electrodes are eroded, switching to a colder heat range spark plug is recommended.

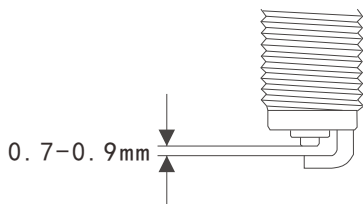

### Spark plug gap:

0.7-0.9mm

### Installing the spark plug

Clean the spark plug washer contact surface and wipe away any dirt from the spark plug threads.

### Locking torque:

Spark plug:  
13N.m

### ⚠ WARNING

• Incorrect installation of spark plugs may damage the engine cylinder head. Excessive torque or cross-threading during installation can also cause damage. Exercise caution during installation. If a torque wrench is unavailable when installing a new spark plug, tighten until resistance is felt, then rotate an additional 3/8 turn (135°. For used spark plugs, tighten until resistance is felt, then rotate an additional 1/12 turn (30°). However, always aim to achieve the specified torque whenever possible.

- Dirt entering the spark plug hole can damage the engine. After removing a spark plug, cover the spark plug hole with a non-woven cloth or other lint-free, residue-free soft material to prevent contamination
- Do not use spark plugs with a heat rating lower than BN8RT1P-8.

## Engine oil

The longevity of the engine depends on using high-quality oil and regular oil changes. Regularly checking the oil level and changing the oil are two essential maintenance tasks.

### Check the engine oil level

Follow the steps below to check the engine oil level.

- 1.Park the motorcycle on a level surface and deploy the main stand or keep the vehicle upright.
- 2.Start the engine and let it idle for 3-5 minutes.
- 3.Stop the engine and wait for 3-5 minutes.
- 4.With the vehicle held upright, observe the oil inspection window. The oil level should be between the MIN and MAX level marks.

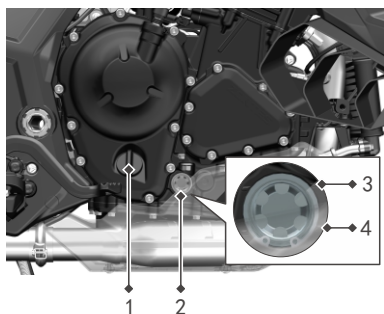

1. Engine oil filler cap
2. Engine oil sight window
3. Max oil level line
4. Min oil level line

## ⚠ CAUTION

• The engine oil level should be between the MAX and MIN lines.

5. If the engine oil is found to be below the minimum oil level, remove the engine oil filler cap and add oil.
6. Check whether the engine oil filler cap O-ring is damaged. If damaged, replace it in time.

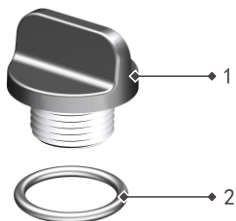

1. Engine oil filler cap
2. O-ring

## Change engine oil and oil filter

Replace the engine oil when the maintenance interval is reached. Oil replacement should be performed with the engine warm (after idling for 3–5 minutes) so that the old oil drains more completely. Follow the steps below:

1. Place the motorcycle on a level surface using the main stand. Start the engine and let it idle for 3–5 minutes, then stop the engine and wait for 3–5 minutes.
2. Place an oil drain pan under the engine drain bolt to collect the used oil.
3. Remove the engine oil filler cap and O-ring. Use a socket wrench to remove the engine drain bolt and washer, and drain the old oil.

**Do not start or run the engine while the oil is being drained. Always ensure there is sufficient oil in the engine before starting.**

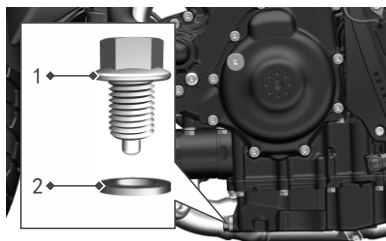

1. Engine drain bolts
2. Washer

4.Reinstall the drain bolt with a new washer (clean the threads before installation). Tighten the drain bolt with a torque wrench according to the specified torque ( $40 \pm 3 \text{ N}\cdot\text{m}$ ).

## ⚠ CAUTION

•It is recommended to use a funnel when refilling oil.

## WARNING

•Using oil not specified may cause engine damage.

## DANGER

•When the engine is running, it is forbidden to open the fuel filler nut to prevent the high-temperature oil from splashing out and injuring people.

5.Place an oil pan under the oil filter.

6.Remove the oil filter using a filter wrench.

7.Wipe away residual oil and contaminants with a clean non-woven cloth.

8.Install a new oil filter: Before installation, add a small amount of oil into the new filter, and apply a thin layer of engine oil to the seal. Then tighten the oil filter.

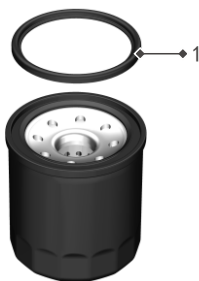

### 1.Oil filter seal ring

①Add engine oil through the engine oil filler opening

### Tightening torque:

Engine oil drain bolt:  
 $40 \pm 3 \text{ N}\cdot\text{m}$

Oil filter  
 $20 \pm 2 \text{ N}\cdot\text{m}$

### Engine oil recommendation

Engine oil (SN10W—50/1L)

### Engine oil change capacity

Replace the oil:  
3.0 L

Replace the oil filter:  
3.4 L

②After checking the O-ring on the engine oil filler cap, install the filler cap.

③Run the engine at varying speeds for 3 minutes. During operation, check for oil leaks around any parts that were removed or reinstalled.

## Maintenance

### CAUTION

•Always wipe off any spilled oil before starting the engine.

---

9. Let the engine idle for 5 minutes, then shut it off and wait 3 minutes. Check the engine oil level via the sight window marks (ensure the oil level is within the marked range). Recheck for any leaks.

### CAUTION

• Before installing the oil filter, carefully inspect whether the seal ring is correctly seated in its groove and check for any damage or cuts. Replace it immediately if damaged; otherwise, oil leakage may occur.

---

## Coolant (antifreeze)

### Recommended coolant:

TOTAL antifreeze

### Total amount of coolant (antifreeze):

1900ml (250ml with auxiliary water tank)

### Coolant

Check the coolant level in the reserve tank when the engine is cool.

1. Place the motorcycle on a stable, level surface.
2. Support it upright using the main stand.
3. Check that the coolant level in the reserve tank is between the Higher and lower level marks.

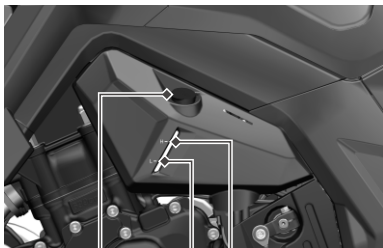

1 2 3

1. Coolant reserve tank cover
2. Lower level mark (L)
3. Higher level mark (H)

4. If the coolant level is below the Lower level mark (L), remove the coolant reserve tank cap.

### ⚠ CAUTION

• Only remove the coolant reserve tank cap. When the engine is very hot, never remove the radiator cap.

5. Add antifreeze until the level is between the marks.

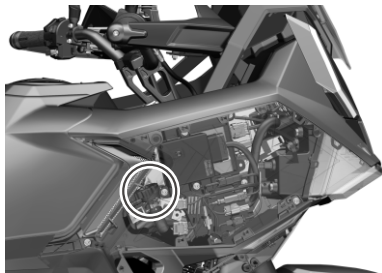

Coolant main tank cover

### ⚠ CAUTION

• If water needs to be added, use distilled water only as a temporary substitute. Other types of water may cause corrosion and other adverse effects to the engine cooling system.

6. Reinstall the coolant reserve tank cap.

# Maintenance

## CAUTION

• Procedure for Refilling Coolant in the Main Radiator: Ensure all hoses and clamps are properly installed. Remove the right side cover and fog light controller. Take off the filler assembly and open the filler cap. Slowly and continuously add coolant until the liquid level reaches the filler neck. Start the vehicle and let it idle. Once the instrument panel shows two temperature bars, you may gently rev the engine to around 3000 rpm. Continue adding coolant as needed during this process. When the middle of the main radiator feels noticeably warm, tighten the filler cap. Let the engine idle for about 1 more minute before turning it off. After the engine has cooled down, reopen the cap and top up the coolant to complete the refilling of the main radiator.

### Engine coolant (antifreeze)

Use a coolant (antifreeze) specifically formulated for aluminum radiators, typically a mixture of antifreeze concentrate and distilled water in specified proportions. This coolant can be used as long as the outdoor temperature does not fall below its freezing point. When adding or replacing coolant, use only ethylene glycol-based antifreeze compatible with aluminum radiators.

## DANGER

• Swallowing or inhaling antifreeze can be harmful. Do not eat, drink, or smoke while handling it. Thoroughly wash hands, face, and any exposed skin after use. If swallowed, contact a poison control center or hospital immediately. If inhaled, move to a well-ventilated area with fresh air. If splashed into eyes, rinse immediately with plenty of running water and seek medical attention. Keep children and pets away from antifreeze.

### Coolant change

Coolant should be replaced at intervals specified in the user manual's maintenance schedule. This task should be performed by an authorized ZONTES dealer.

## Air filter

The air filter should be replaced regularly according to the periodic maintenance schedule in the user manual. Please have the air filter replaced at ZONTES flagship stores or authorized dealerships.

### Inspecting the air filter

The air filter is located on the inside side of the left enclosure panel. If the air filter is blocked by dust, it will increase the intake resistance, decrease the output power, and increase the fuel consumption. Follow the steps to check the clean air filter.

### **⚠ WARNING**

- Under normal conditions, the air filter element should be replaced or serviced every 1,000 km. The air filter does not have a quick maintenance feature. After quick maintenance, it can continue to be used for 4,000 km before the next service or element replacement.
- If riding in dusty conditions, increase the frequency of cleaning or replacing the filter element.
- Operating the engine without the air filter installed is dangerous. Without the inner filter element to block it, engine backfire flames could travel into the air filter intake chamber. Dirt may also enter the engine, causing damage. Do not operate the engine without the air filter element installed.

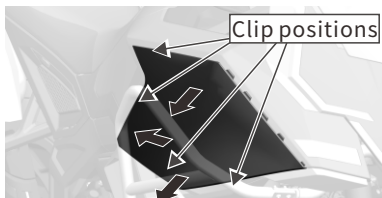

Remove the left side cover (refer to section 6-8 for removal instructions).



2. Remove the five screws and take out the air filter's (left intake chamber) bright cover.



3. Remove the filter element (for detailed instructions, please refer to the video on the official website).

### **⚠ CAUTION**

- Inspect the removed filter element. Use a high-pressure air gun to blow off contaminants from the clean side. If the filter is heavily soiled or damaged, it must be replaced.
- Reassemble the motorcycle in the reverse order of removal.

### CAUTION

•If the air filter element is not installed correctly, dust may bypass the filter and enter the engine, causing damage. Ensure the filter element is properly seated. Additionally, when washing the motorcycle, do not allow water to enter the air filter. If water enters, it can be drained by removing the drain tube. Make sure there is no residual water inside the air filter before using the motorcycle.

---

## Drift tube

The air filter drain tube should be inspected and the accumulated oil should be drained regularly according to the periodic maintenance schedule in the user manual. It is recommended to have the air filter drain tube condition checked at ZONTES flagship stores or authorized dealerships.

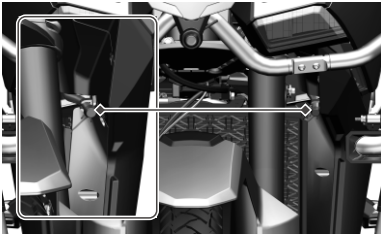

1.As shown in the diagram, this is the drain tube for the left intake chamber. Use needle-nose pliers to remove the retaining clip, pull out the plastic plug, and drain the waste oil. After completion, reinstall the components in the reverse order to restore the original condition.

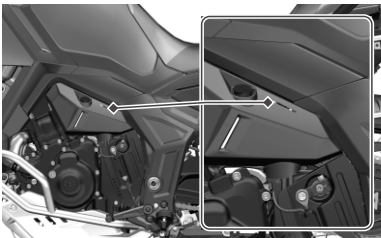

2.As shown in the diagram, this is the oil level inspection window for the air filter drain tube (oil should be drained when accumulation is visible in the tube).

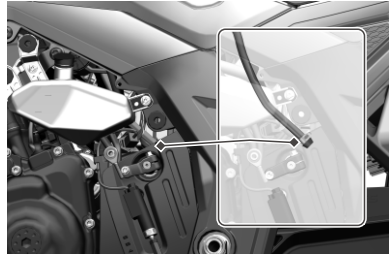

3.Remove the left side cover of the reserve tank (refer to the reserve tank removal procedure). Use needle-nose pliers to remove the retaining clip, pull out the plastic plug, and drain the waste oil. After completion, reinstall the components in the reverse order to restore the original condition.

# Maintenance

## Engine idle speed check

Check the engine idle speed. If necessary, please visit a ZONTES dealership for inspection and adjustment.

### Engine idle speed:

1350±100 r/min

## Adjusting the brake lever play

J.JUAN

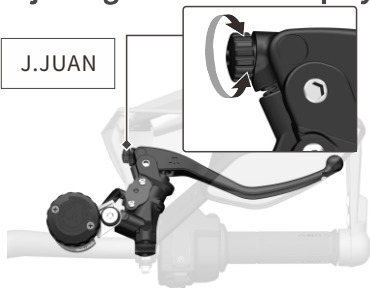

Push the front brake lever toward the front of the motorcycle while turning the adjustment knob. Release the front brake lever and test whether the gap is comfortable for operating the lever. Turning the adjustment knob clockwise increases the gap between the front brake lever and the handlebar.

After adjustment, check whether the brake lever functions properly before riding.

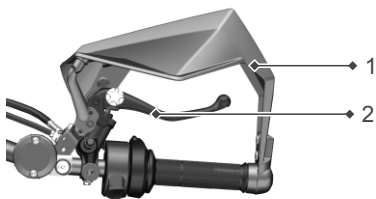

1.Hand guard

2.Brake lever



1. No Free Play in the Brake Lever  
There should be no free play in the brake lever. If free play exists, please have the brake system inspected at a ZONTES flagship store or authorized dealership.

### **⚠ DANGER**

•If the brake lever feels soft or spongy when operated, it indicates air inside the hydraulic brake system. Please have the brake system bled by a ZONTES dealership or flagship store before riding. Air inside the brake system will reduce braking effectiveness, which may cause loss of control and an accident.

## Check the clutch lever free play

Measure the free play of the clutch lever as shown in the diagram.

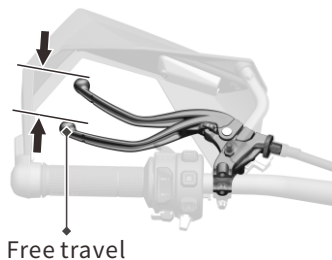

### Clutch handle free travel:

10-15mm

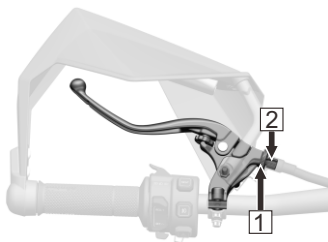

Check the clutch lever free play regularly and adjust it according to the following procedure when necessary:

1. Remove the protective cap on the nut.
2. Loosen the locknut [1].
3. Rotate the adjustment nut [2] to make the adjustment.
4. Tighten the locknut [1].

(Note: Inspect the clutch cable for any bends or damage. If necessary, have it replaced by a ZONTES authorized service center. Use commercially available cable lubricant to lubricate the clutch cable to prevent premature wear and corrosion.)

### ⚠ CAUTION

- If the specified free play cannot be achieved, or if the clutch becomes inoperable, please visit a ZONTES flagship store or authorized dealership for clutch inspection.
- Incorrect adjustment of the free travel will cause premature wear of the clutch.

## Side stand

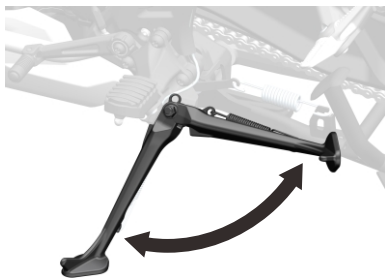

### Side stand

When the side stand is deployed, if the clutch lever is not held and the transmission is not in neutral, the side stand cut-off switch will cut the power and the engine will stop.

### **⚠ CAUTION**

- Check that the side stand operates smoothly. If the side stand is stiff or makes squeaking noises, clean the pivot area and lubricate the bushings with clean lubricant.
- Check the spring for any damage or loss of tension.

## Shift level

This motorcycle is equipped with a six-gear transmission. Shift gears by pressing the shift lever downward or lifting it upward. Before downshifting, reduce the vehicle speed or increase the engine speed. Before upshifting, increase the vehicle speed or decrease the engine speed. This helps prevent unnecessary wear on the drivetrain components and the rear tire.



### **⚠ WARNING**

•When the transmission is in the neutral position and the neutral indicator light is on, gradually release the clutch lever to confirm that the motorcycle is truly in neutral.

## Rear grab rail (rear luggage rack)

Do not exceed the maximum load limit.

### Maximum load:

10 kg

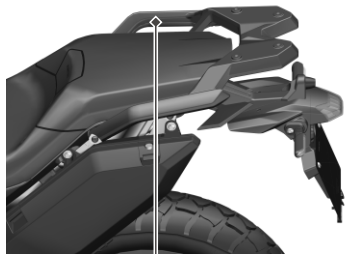

Rear grab rail  
(rear luggage rack)

## Fuel tank cap

The fuel tank is located in front of the seat. Before opening the outer fuel tank cap, ensure the engine stop switch is in the OFF position. The vehicle's electrical system must be powered on to open the tank cap. Lift the small cover plate to open the fuel tank cap. Always ensure the fuel tank cap is in the locked position when leaving the vehicle unattended after parking.

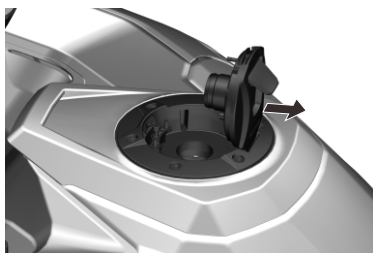
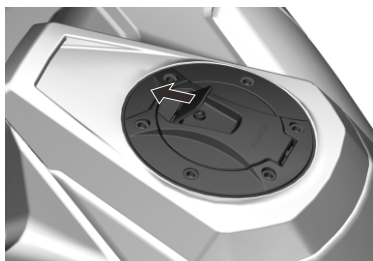

### Fuel type:

Unleaded gasoline only

### Fuel octane rating:

Your motorcycle is designed to use gasoline with a Research Octane Number (RON) of 95 or higher.

### Fuel tank capacity

22L (Oil consumption: 5.0 L/100km)

## ⚠ DANGER

- Do not overfill the tank, as spilled fuel may flow onto the hot engine. Stop refueling when the nozzle automatically clicks off. The fuel level must not exceed the bottom of the filler neck, as heat expansion may cause overflow and damage motorcycle components.
- Turn off the engine and ensure the stop switch is in the "OFF" position during refueling. Keep away from open flames.
- Take precautions to prevent fires or inhalation of fuel vapors. Refuel in a well-ventilated area. Ensure the engine is off, avoid fuel spills, prohibit open flames, and keep all heat and ignition sources away. Avoid inhaling fuel vapors. Keep children and pets away during refueling.

## ⚠ CAUTION

- Do not use high-pressure water to clean the fuel tank cap during washing, as water may enter the tank.
- If the fuel tank cap is stuck, press it firmly downward. After restarting the vehicle, attempt to open it again.
- Do not let the fuel nozzle touch the bottom of the tank during refueling, as this may damage the tank and cause leaks.

## Adjust the front suspension system

### Spring preload

The spring preload adjustment knob can be rotated using a No.14 socket wrench. The standard position is achieved by turning the knob counterclockwise to its limit and then clockwise by 4 turns.

The spring preload adjustment range is 10 turns. Turning clockwise increases the spring preload (makes it firmer), while turning counterclockwise decreases the spring preload (makes it softer).

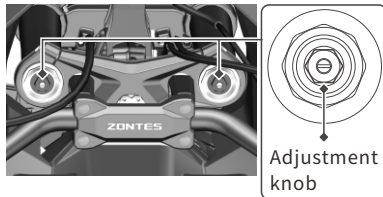

### ⚠ CAUTION

• Do not turn the adjustment knob beyond its limits. The preload for both left and right shock absorbers should be adjusted to the same position.

### Compression damping adjustment

The front shock absorber compression damping adjustment knob can be rotated using a flat-head screwdriver. The adjustment range is 4 turns. The standard position is achieved by turning the knob clockwise to its limit and then counterclockwise by 2.75 turns.

Turning clockwise increases the compression damping (makes it firmer), while turning counterclockwise decreases the compression damping (makes it softer).

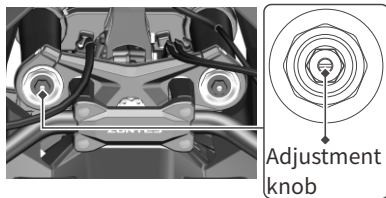

### ⚠ CAUTION

• Do not turn the adjustment knob beyond its limits.

# Maintenance

## Rebound damping adjustment

The front shock absorber rebound damping adjustment knob can be rotated using a flat-head screwdriver. The adjustment range is 4 turns. The standard position is achieved by turning the knob clockwise to its limit and then counterclockwise by 1.75 turns.

Turning clockwise increases the rebound damping (makes it firmer), while turning counterclockwise decreases the rebound damping (makes it softer).

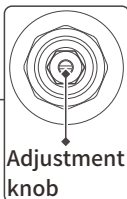
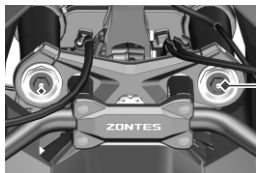

### CAUTION

- Do not turn the adjustment knob beyond its limits.

## Adjust the rear suspension system

### Rear shock absorber rebound damping adjustment knob

The rear shock absorber rebound damping adjustment knob can be rotated using a flat-head screwdriver. It has an adjustment range of 70 clicks. As the damping force needs to be set within a fixed range from the factory to ensure shock absorber performance, each shock absorber is individually tested and adjusted, meaning the factory setting of the damping adjustment knob is not fixed. It is recommended to first mark a reference line near the knob with a marker pen. Before each adjustment, return the knob to its factory position (aligning with the mark) before making changes. Turning clockwise increases the rebound damping (makes it firmer), while turning counterclockwise decreases the rebound damping (makes it softer).

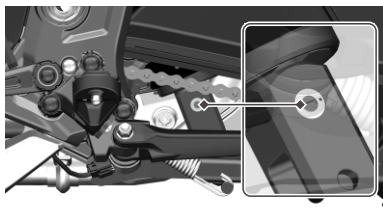

## Compression damping

The rear shock absorber compression damping knob is located below the rear mounting bracket of the fuel tank. After removing the seat, it can be rotated using a flat-head screwdriver. It has an adjustment range of 15 clicks. The standard position is achieved by turning the knob counterclockwise to its limit and then clockwise by 7 clicks. Turning clockwise increases the compression damping (makes it firmer), while turning counterclockwise decreases the compression damping (makes it softer).

## Spring preload

The spring preload adjustment knob can be rotated manually. It has an adjustment range of 15 turns. The standard position is achieved by turning the knob counterclockwise to its limit and then clockwise by 1.5 turns. Turning clockwise increases the spring preload (makes it firmer), while turning counterclockwise decreases the spring preload (makes it softer).

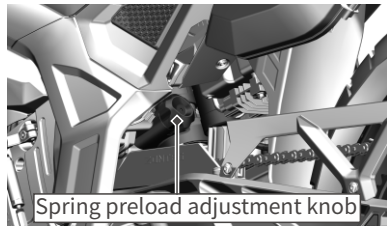
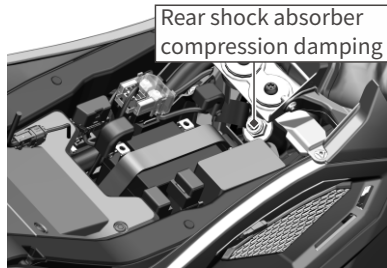

## ⚠ CAUTION

- Do not turn the adjuster beyond its limits.
- The rear shock absorber damping unit contains high-pressure nitrogen gas. Do not attempt to disassemble, repair, or dispose of the damper improperly. Please have it serviced by a ZONTES flagship store or authorized dealership.

# Maintenance

## Suspension system adjustment recommendations

	Setting	Solo Riding	Load in Addition to Rider		
			With Panniers	With Passenger	With Passenger and Panniers
Front Suspension	Preload	4 turns (out of 10)	4turns	4turns	4turns
	Rebound (R)	1.75 turns (out of 4)	1.75turns	1.75turns	1.75turns
	Compression (C)	2.75 turns (out of 4)	2.75turns	2.75turns	2.75turns
Rear Suspension	Preload	1.5 turns (out of 15)	4turns	6turns	10turns
	Rebound	19 clicks (out of 70)	17clicks	15clicks	12clicks
	Compression	8 clicks (out of 15)	6clicks	6clicks	5clicks
Remarks	<ul style="list-style-type: none"> <li>•For both front and rear suspension, spring preload is adjusted by turning clockwise from the fully counterclockwise position. Clockwise rotation increases preload, counterclockwise decreases it.</li> <li>•For both front and rear suspension, damping force is adjusted by turning counterclockwise from the fully clockwise position. Clockwise rotation increases damping, counterclockwise decreases it.</li> <li>•The factory damping settings for the rear shock absorbers may vary. Note the vehicle's factory setting positions before making adjustments.</li> <li>•Balanced front/rear suspension sag under load: 50mm for the front fork, 26mm for the rear shock absorber.</li> <li>•Adjustment order: First adjust spring preload to achieve balanced front/rear sag when the rider is seated, then fine-tune damping forces as needed.</li> <li>•The first 1000 km of vehicle mileage is considered the suspension break-in period. Avoid adjustments during this period.</li> </ul> <p>The above is for reference only. Adjust according to specific conditions.</p>				

## Upper triple clamp damping rubber troubleshooting

Trouble-shooting Step	Phenomenon Description		Trouble-shooting Step	Normal Condition	Troubleshooting Step
Hold the front brake and rock the handlebars forward and backward	No significant play indicates normal condition				
	Significant looseness indicates the need to check two potential scenarios	Case one	Tighten the upper triple clamp bracket mounting bolt to the specified torque	60N·m	If the issue is resolved after torquing, return to normal operation. If the issue persists, proceed to Case 2.
		Case two	Remove the upper triple clamp damping rubber and inspect its appearance	No deformation	If the rubber is deformed, cracked, or has lost elasticity (almost no rebound when pressed by hand), the damping rubber is aged and must be replaced.
				No cracks	
Normal rebound					

# Maintenance

## Transmission chains

This model is equipped with a drive chain made of special materials. When the drive chain needs to be replaced, please have this task performed at a ZONTES flagship store or authorized dealership. Check and adjust the motorcycle's drive chain before riding each day. Perform inspection and maintenance according to the following method.

### **⚠ DANGER**

• **To ensure safety, the inspection and adjustment of the drive chain should always be performed before riding.**

### Inspecting the drive chain

When inspecting the drive chain, check for the following issues:

- Loose chain pins.
- Broken or damaged sprocket teeth.
- Links that do not rotate freely.
- Excessive wear.
- Improper chain adjustment, indicated by inconsistent alignment marks on the left and right sides of the swingarm.
- Dryness, severe rust, or heavy dirt accumulation.
- Whether the chain has reached the end of its service life.

### **⚠ WARNING**

• **If any of the above problems are found, please contact a ZONTES flagship store or authorized dealership for service.**



Good shape



Shape wear

### **⚠ CAUTION**

• **When inspecting or replacing the drive chain, also check the wear condition of both the front and rear sprockets and the swingarm chain slider. Replace them if necessary.**

### Drive chain cleaning and lubrication

Clean and lubricate the drive chain regularly using the following method:

1. Remove dirt and dust from the chain.
2. Clean the chain with a sealed chain cleaner or a mixture of water and a neutral detergent. Use a soft-bristled brush to clean dirt and dust from the surface of the O-rings.
3. Wipe away the water and neutral detergent, then allow the chain to dry completely.
4. Apply motorcycle-specific chain lubricant for sealed chains, ensuring it lubricates the O-rings, rollers, and both the inner and outer link plates.
5. After thoroughly lubricating the chain, wipe off any excess lubricant. Allow the chain to sit for at least 30 minutes to let the lubricant fully penetrate and provide effective lubrication.
6. Maintain proper chain lubrication.

## Adjustment of the transmission chain

Adjust the slack of the transmission chain to the appropriate range. Increase the frequency of adjustment of the transmission chain according to the driving conditions.

### **WARNING**

• Excessive drive chain slack is dangerous. If the chain derails, it may damage the engine. Also, a severely loose chain moving at high speed can cut into and damage the swingarm, potentially causing deformation or breakage. Always check and adjust the chain slack before riding.

---

# Maintenance

## Check the drive chain slack

Adjust the drive chain slack to within the appropriate range. Check the chain slack before each ride and adjust if necessary.

1. Place the motorcycle on the center stand.
2. Shift the transmission into neutral.
3. Measure the drive chain slack as shown in the figure.

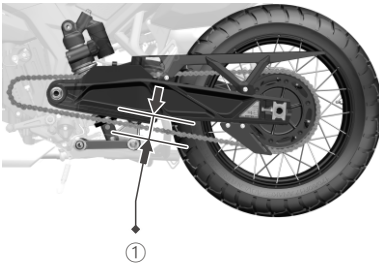

① Drive chain slack

### Drive chain slack:

35-45mm

4. If the drive chain slack is incorrect, adjust it according to the following procedure.

## Adjust the drive chain slack

1. Remove the cotter pin using pliers, then loosen the rear axle bolt using a 30-size wrench or socket.
2. Loosen the lock nut using a 13# open-end wrench.

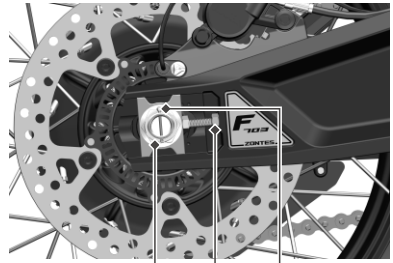

① Rear axle nut

② Lock nut

③ Cotter pin

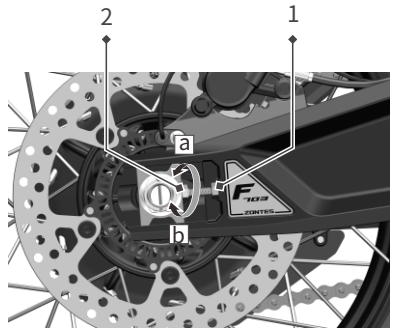

## Drive chain slack adjusting bolts

1. Use a wrench to loosen the lock nut.
2. To tighten the drive chain, turn the drive chain slack adjusting bolt on the swingarm in direction (a). To loosen the drive chain, turn the drive chain slack adjusting bolt on the swingarm in direction (b), then push the rear wheel forward.

Note: Perform the above adjustment on both the left and right adjusting bolts of the swingarm.

## WARNING

•Adjust the drive chain to the proper slack (35-45 mm). To ensure the rear wheel is aligned straight, adjust the adjustment markers on both sides to the same position relative to the swingarm scale.

3. After completing the adjustment, tighten the lock nut and the rear axle nut. Install the cotter pin into the corresponding hole and bend it at least 120 degrees using pliers.

### Rear axle nut locking torque

120-130N.m

## WARNING

•The drive chain on this motorcycle is precision-made from special materials. It is strongly recommended to use only this company's O-ring chain when replacement is required. Using other drive chains that have lower tensile strength or are of inferior quality may cause chain breakage, which could damage the vehicle or cause personal injury. When an O-ring chain has reached the end of its service life due to wear and elongation, it must not be shortened by removing links and re-riveting. Operating a chain that is severely beyond its fatigue life may cause breakage, which could damage the vehicle or cause personal injury.

## Check chain service life

A properly maintained O-ring chain has a normal service life of 10,000 to 15,000 kilometers. Replace the chain promptly when it has worn and elongated to the end of its service life:

- 1.It is recommended to replace it with a genuine 525 O-ring chain.
- 2.If using an O-ring chain with a master link (split-type), a dedicated riveting tool must be used. Before riveting, evenly apply special lubricant to the O-rings on the link pins. Ensure the O-rings and link plates are clean and free of debris. When flaring the pin ends, it is recommended to perform the riveting process in multiple steps. The pin hole must not be cracked or shattered. The flare size must ensure the riveted link pivots freely and the outer link plate will not dislodge or fall off during normal riding.

## WARNING

•If the swingarm chain slider fails, the high-speed moving chain can not only cut into and damage the swingarm but also damage the chain itself. Breakage of the swingarm or chain could damage the vehicle or cause personal injury.

# Maintenance

## Check the swingarm chain slider

1. Every 500 to 1,000 kilometers when cleaning the O-ring chain, always inspect the raised surface (Surface A) and the flat surface (Surface B) of the swingarm chain slider. When surface B develops a groove deeper than approximately 1 mm from contact with the chain's inner and outer link plates, the swingarm chain slider must be replaced immediately to prevent it from being worn through by the chain.

2. When installing a new O-ring chain, check the wear condition of the swingarm chain slider. If the slider is worn very thin by the chain, or if a groove of approximately 1 mm is present where the chain's inner and outer link plates make contact, a new swingarm chain slider must be installed to prevent the chain from wearing through the slider and damaging the swingarm.

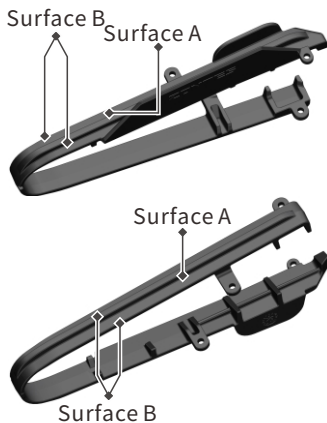

## Tires (Inspection/ Replacement)

### Check tire pressure

Check tire pressure before riding on unpaved winding roads and after returning to paved roads from unpaved terrain. If riding exclusively on paved roads, check pressure at least monthly or when insufficient pressure is suspected. Always check tire pressure when the tires are cool.

### Recommended tire pressure:

Front wheel:  
250kPa

Rear wheel:  
250kPa

### Damage inspection

Check tires for cuts, cracks, exposed fabric or cords, or nails/foreign objects embedded in the sidewalls or tread. Also inspect sidewalls for abnormal bulges or swelling

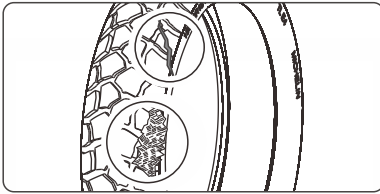

### Abnormal wear inspection

Check the contact surface of the tires for signs of abnormal wear.

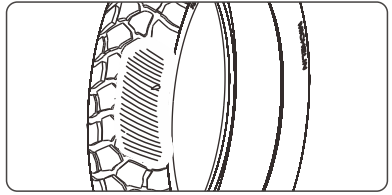

### Check tread depth

Check the tire wear indicators. If the wear indicators become visible, replace the tires immediately. For safe riding, tires should be replaced when the minimum tread depth is reached.

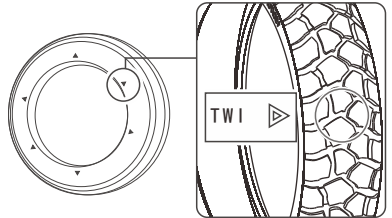

### Tire replacement

Have tires replaced by an authorized ZONTES service center.

For recommended tires, pressures, and minimum tread depths, refer to the "Technical Specifications" section. Whenever replacing tires, follow these guidelines:

- Use the recommended tires or equivalent products with the same size, construction, speed rating, and load capacity.
- After tire installation, balance the wheels using genuine ZONTES balancing weights or equivalent equipment.

# Maintenance

- Do not install inner tubes in tubeless tires on this motorcycle. Excessive heat may cause inner tubes to burst.
- This motorcycle is designed for tubeless tires only. The rims are engineered for tubeless tires. Installing tubed tires may cause slippage on the rim during hard acceleration or braking, leading to rapid air loss.

## DANGER

- **Installing unsuitable tires may compromise handling and stability, resulting in accidents that could cause injury or death.**
- **Always use tires of the size and type recommended in this Owner's Manual.**

## Check rims and valves stems

Before each ride, inspect the rims for damage and check if the spokes are loose. Additionally, examine the position of the valve stems.

## WARNING

- **Using excessively worn or improperly inflated tires may lead to accidents causing serious injury or death.**
- **Always follow the tire inflation data and maintenance guidelines provided in this Owner's Manual.**

## Wheels

### Rims and spokes

To ensure safe motorcycle operation, the wheels must be round with properly tensioned spokes. Loose spokes or wheel distortion may cause instability at high speeds and potential loss of control.

Wheel removal is not required for the maintenance tasks listed in the schedule. Perform the following checks:

1. Check if the rims are distorted or out of round.
2. Inspect spokes for looseness or detachment. If found, have them serviced by an authorized ZONTES service center.
3. Slowly rotate the wheel to check for wobbling. Significant wobbling indicates an out-of-round rim—seek professional repair at a ZONTES service center.

## Brake system

### Check brake fluid

1. Place the motorcycle upright on a stable, level surface with the handlebars level.
2. Check that the brake fluid level is above the lower limit mark.
3. If the fluid level in any reservoir is below the lower mark, or if the brake lever free play exceeds specifications, inspect the brake pad wear. If the pads show minimal wear, there may be a leak—have the system inspected by an authorized ZONTES service center.

Front brake fluid reservoir

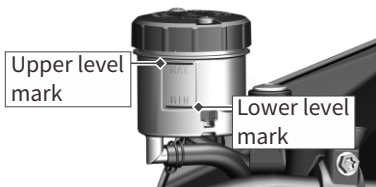

Rear brake fluid reservoir

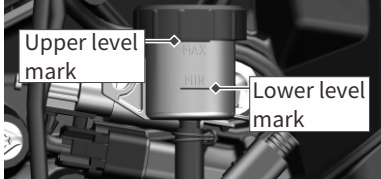

### Check brake pads

Inspect the condition of the brake pad wear indicators.

Front wheel: Replace the brake pads if worn down to the base of the indicators.

Rear wheel: Replace the brake pads if worn down to the indicator marks.

### Front brake caliper

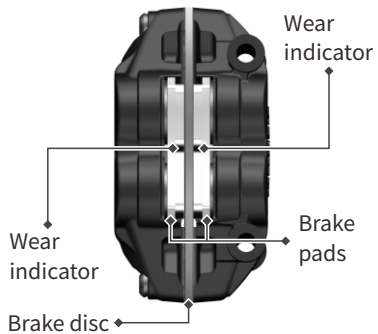

### Rear brake caliper

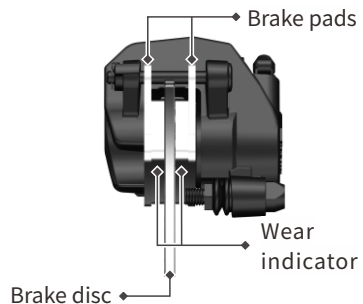

# Maintenance

Front wheel: Check the brake pads from the front of the brake caliper.

Rear wheel: Check the brake pads from the right rear side of the motorcycle.

If replacement is needed, have the brake pads replaced by an authorized ZONTES service center. Always replace brake pads in pairs (both sides simultaneously).

## Adjust the brake light switch

Check if the brake light switch is functioning correctly. If the switch reacts too slowly, hold the brake light switch and rotate the adjusting nut counterclockwise. If the switch reacts too quickly, rotate the adjusting nut clockwise.

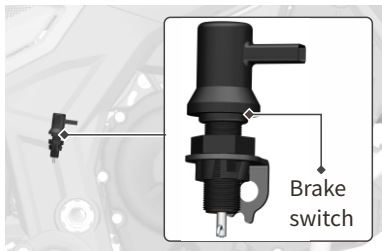

## Headlight adjustment

1. The headlight has two independently adjustable sections: the high beam and the low beam adjustment points. These are accessible after removing the left and right side covers. (Height adjustment should be performed on both the left and right headlights.)

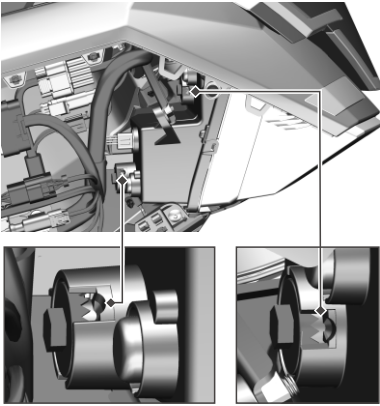

Low beam  
adjustment

High beam  
adjustment

2. Use a #6 × 150-200 mm cross-tip screwdriver. Insert it into the adjustment hole. Turn counterclockwise to lower the beam, and clockwise to raise it. Note: During adjustment, ensure the screwdriver tip engages properly with the teeth of the adjustment bolt. During adjustment, the cross-tip screwdriver must engage properly with the teeth of the adjustment bolt. For more detailed steps, please watch the related video on the official website.

# Maintenance

## Installing additional electrical accessories

The vehicle comes pre-equipped with a retrofit connector for auxiliary lights, an anti-theft alarm connector, and an OBD diagnostic port.

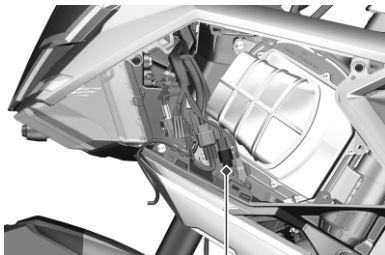

Retrofit connector for auxiliary lights

Remove the left side cover (refer to pages 6-8). After removal, the retrofit connector for auxiliary lights will be visible.

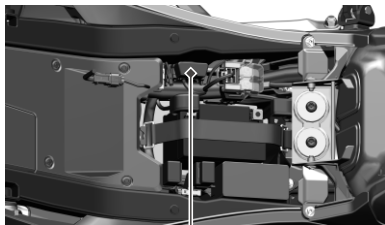

OBD diagnostic port

The OBD diagnostic port is located under the seat. Briefly press the "SEAT" button on the left handlebar switch to open the seat.

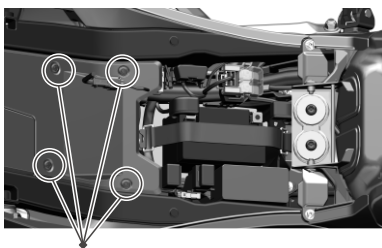

Expansion rivet

Remove the four expansion rivets on the electrical component cover in the battery compartment, then take off the cover.

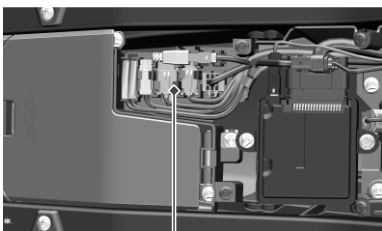

Anti-theft alarm connector

The anti-theft alarm connector is located under the electrical component cover in the battery compartment. It becomes visible once the cover is removed.

**⚠ WARNING**

- It is prohibited to connect power-consuming devices such as GPS units or fog lights directly to the positive and negative terminals of the battery.
- Wiring for power-consuming devices must not be routed in close contact with the sides of the battery.
- Installed power-consuming devices must be positioned at least 300 mm away from the fuel injection ECU, relay assembly, and PKE controller.
- Any consequences resulting from unauthorized wire modifications or improper installation of additional devices will be the responsibility of the consumer.
- **The total power consumption of externally connected devices must not exceed 60W. Do not use auxiliary lights while the engine is idling.**

The peak output power of the magneto is:

14V 30A 5000rpm

# Troubleshooting

## Fuse locations

The fuses are located under the seat. Briefly press the "SEAT" button on the left handlebar switch to open the seat for access.

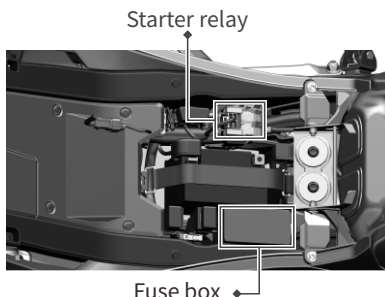

### Fuse

The main fuse and one spare fuse are located on the starter relay. The LCM fuse, ECM fuse, constant power fuse, ABS motor fuse, fuel pump fuse, starter fuse, ABS fuse, auxiliary fuse, other fuses, and four additional spare fuses are located in the fuse box.

- Main Fuse: Protects all electrical circuits.
- LCM Fuse: Protects the LCM circuit.
- ECM Fuse: Protects the ECM, ECM relay, fuel pump relay, and related components.
- Constant Power Fuse: Protects the fan, instrument cluster, and anti-theft alarm connector.
- ABS Motor Fuse: Protects the ABS motor.
- Windshield Fuse: Protects the windshield circuit.

- Starter Fuse: Protects the starter circuit.
- ABS Fuse: Protects the ABS controller.
- Auxiliary Fuse: Protects auxiliary components (position lights, turn signals, tail light, brake light, license plate light, horn, passing light).
- Other Fuse(s): Protect components connected to the handlebar switch (except the steering lock switch), instrument cluster, and anti-theft alarm connector.

### ⚠ DANGER

• Do not use fuses with specifications other than those specified or bypass them with direct connections. This may severely damage the electrical system, cause fires, burn out the vehicle, or lead to loss of engine power, posing extreme hazards.

### ⚠ CAUTION

• Always use fuses with the specified current rating. Do not use substitutes such as aluminum or iron wires. If a fuse repeatedly blows in a short period, it indicates an electrical system fault. Immediately have the system inspected by a service center.

## Catalytic converter

The catalytic converter effectively reduces pollutants from your vehicle's emissions, protecting our environment. Its lifespan is designed under the premise of using unleaded gasoline. Do not use leaded gasoline, as lead will permanently damage the converter's reduction components. Proper engine operation is critical for the converter. Prolonged engine misfiring or insufficient cooling may cause unburned fuel to accumulate and ignite in the converter, leading to overheating and permanent damage. Avoid maintaining high engine speeds while stationary for extended periods.

# Troubleshooting

## Fault diagnosis

The troubleshooting section assists in identifying causes of common issues.

### WARNING

- **Incorrect repairs or adjustments may damage the motorcycle without resolving the fault. Such damage is not covered under warranty. If unsure about proper procedures, consult an authorized service center.**
- **Before troubleshooting, contact an authorized service center. They will assist in resolving the issue. If the engine fails to start, follow the checks below to determine the cause.**

### Fuel system inspection

If the engine malfunction indicator on the instrument panel illuminates, it indicates a issue with the fuel injection system. Take the motorcycle to an authorized service center. Refer to the "Engine Malfunction Indicator" section in the instrument panel chapter for detailed explanations.

### Engine failure to start

- Ensure sufficient fuel in the tank.
- If the orange EFI fault light illuminates during operation after successful starting, it indicates an abnormal fuel injection system. Contact an authorized service center for inspection.
- Check the ignition system for proper function.
- Check idle speed. The correct idle speed is  $1350 \pm 100$  rpm.

### DANGER

- **Do not allow fuel to spill onto the ground; collect it in a container. Keep fuel away from the hot engine and muffler. Perform checks away from open flames, ignition sources, and heat sources.**

### Insufficient engine power

If engine power significantly decreases or the maximum speed drops substantially, it may indicate a clogged fuel system causing abnormal engine operation. Immediately visit an authorized service center for inspection.

### WARNING

- **Fuel system clogs may result from contaminated gasoline.**
- **For new motorcycles or vehicles that have run out of fuel, do not turn on the ignition switch until refueling is complete. Running the fuel pump dry severely shortens its lifespan.**

## Carbon deposit cleanup

To minimize carbon buildup, the following is recommended:

- 1.If the vehicle is frequently used for short trips or is consistently operated below 5,000 rpm, it is recommended to clean carbon deposits every 5,000 kilometers or every 6 months. If the vehicle is often operated above 5,000 rpm and the engine is sufficiently warmed up, the cleaning interval can be extended to every 10,000 kilometers or every 12 months.
- 2.Perform the cylinder cleaning procedure as follows: With the transmission in neutral and the clutch lever fully squeezed, fully open the throttle and then press the starter button. The ECU will then recognize this as the cylinder cleaning mode and will stop fuel injection. To exit the cylinder cleaning mode, turn off the ignition and wait approximately 10 seconds. Turning the ignition on again will exit the cylinder cleaning mode.

### Carbon cleaning methods:

- 1.Scavenging Cleaning: During riding, when conditions allow, appropriately increase throttle to raise engine speed above 7,000 RPM for a cumulative duration of at least 2 minutes. High-speed scavenging effectively removes carbon deposits.
- 2.Fuel Additive Cleaning: Use reputable brand fuel system cleaners according to instructions. Avoid frequent use, as it may damage fuel supply lines.

## Fuel injection system precautions

- 1.Before installing the battery on a new motorcycle, ensure all wiring connectors for the fuel injection system components are securely plugged in. This includes ensuring the oxygen sensor is installed and fuel has been added to the tank.
- 2.When installing the battery, securely attach the positive and negative cables to their respective battery terminals using the appropriate tools. Do not hand-tighten.
- 3.Always maintain a minimum of 3 liters of fuel in the tank. Insufficient fuel can affect the proper operation of the fuel injection system. Refuel promptly when the fuel gauge indicates 1 bar or less.
- 4.After reconnecting the battery, if a power interruption occurs while starting or riding, if the battery has been in a dormant/restart state, if idle speed is abnormal, or after re-seating fuses, perform a reset of the fuel injection system hardware as follows: Turn the ignition key ON and set the engine stop switch to RUN (ON). With the transmission in neutral and the clutch lever engaged (pulled in), start the engine and let it run for 60 seconds. Then, turn the engine stop switch OFF. Wait 10 seconds, and then repeat the entire procedure.

# Troubleshooting

5. After the motorcycle has been stationary for an extended period (parked for more than 3 hours), before the initial start, ensure the fuel pump has completed its pressurization cycle. This is done by turning the ignition ON and setting the engine stop switch to RUN (ON). Wait until the whirring sound from the fuel tank stops before starting the engine.

6. Perform the cylinder cleaning procedure as follows: With the transmission in neutral and the clutch lever fully squeezed, fully open the throttle and then press the starter button. The ECU will recognize this as the cylinder cleaning mode and will stop fuel injection. To exit the cylinder cleaning mode, turn off the ignition and wait approximately 10 seconds. Turning the ignition on again will exit the cylinder cleaning mode.

7. If the battery voltage icon on the instrument cluster is flashing, it indicates low battery voltage. Charge the battery promptly. Excessively low voltage may prevent fuel injection components from operating correctly, leading to failure to start, difficult starting, or lack of power.

8. During engine idling, if the battery voltage is low, the idle speed may increase to boost the alternator's charging output. Once the voltage returns to normal, the idle speed will return to its standard value..

## DANGER

• For a new motorcycle or one that has run out of fuel, do not turn the engine stop switch to RUN (ON) before refueling. Operating the fuel pump dry can severely damage it and shorten its lifespan.

---

## WARNING

• Do not arbitrarily disconnect and reconnect wiring harness connectors from various components. Never wash the connectors of fuel injection components with water.

---

## CAUTION

• If the malfunction indicator is off during engine operation but flashes after shutdown, it indicates a historical fault with no impact on vehicle performance. It will resolve automatically.

---

1. During engine operation, if the EFI malfunction indicator on the instrument panel illuminates, it indicates a fault in the EFI components that requires troubleshooting.

1. You can directly read the fault code in the instrument menu → Fault Information page, or retrieve it via the ZONTES Smart APP.



ZONTES intelligent APP QR code

2. Conditions for turning off the instrument panel warning light:

1. Using a Diagnostic Tool to Clear Fault Codes: Turn the motorcycle's electrical system on. Open the seat. Connect the diagnostic tool to the diagnostic port inside the electrical box. Follow the diagnostic tool's operational steps to clear the fault codes.

## **⚠ WARNING**

• If the malfunction indicator is off during engine operation but flashes after shutdown, it indicates a historical fault with no impact on vehicle performance. It will resolve automatically.

# Troubleshooting

## EFI fault codes

NO.	Fault Code	Fault Description
1	P0105	Intake Manifold Pressure Sensor Electrical Fault
2	P0110	Intake Air Temperature Sensor Electrical Fault
3	P0115	Cylinder Temperature Sensor Electrical Fault
4	P0336	Crankshaft Position Sensor Signal Implausibility
5	P0120	Throttle Position Sensor 1 Electrical Fault
6	P0220	Throttle Position Sensor 2 Electrical Fault
7	P2135	Throttle Position Sensor Signal Consistency Fault
8	P2100	Throttle Body Actuator Motor Electrical Fault
9	P0638	Incorrect Throttle Position
10	P0121	Throttle Position Sensor 1 Plausibility Fault
11	P0221	Throttle Position Sensor 2 Plausibility Fault
12	P0130	Upstream Oxygen Sensor Electrical Fault
13	P0030	Upstream Oxygen Sensor Heater Electrical Fault
14	P0225	Rider Foot Pedal Position Sensor 1 Electrical Fault
15	P2140	Rider Foot Pedal Position Sensor 2 Electrical Fault
16	P2130	Rider Foot Pedal Position Sensor Signal Consistency Fault
17	P0351	Cylinder 1 Ignition Coil Electrical Fault
18	P0352	Cylinder 2 Ignition Coil Electrical Fault
19	P0353	Cylinder 3 Ignition Coil Electrical Fault
20	P0201	Cylinder 1 Fuel Injector Electrical Fault
21	P0202	Cylinder 2 Fuel Injector Electrical Fault
22	P0203	Cylinder 3 Fuel Injector Electrical Fault
23	P0443	Evaporative Canister Purge Valve Electrical Fault
24	P0410	Secondary Air Injection Valve Electrical Fault
25	P0230	Fuel Pump Relay Electrical Fault
26	P0480	Fan Relay Electrical Fault
27	P1762	Tip-Over Switch Electrical Fault
28	P0914	Gear Position Sensor Electrical Fault
29	P060B	ECU Internal A/D Converter Module Error
30	P0604	RAM Fault

## EFI fault codes

NO.	Fault Code	Fault Description
31	P0601	EEPROM Fault
32	C001	CAN Bus Communication Interruption
33	C121	CAN Bus ABS Signal Fault
34	P0500	CAN Bus Front Wheel Speed Signal Fault
35	P1615	ROM Checksum Failure
36	P1900	Quick Shifter Sensor Electrical Fault

# Troubleshooting

## LCM function fault code

Serial number	Fault codes	Description of the fault code
1	9002	Spotlights is overloaded
2	9022	Fog lights is overloaded with white light
3	9032	The horn is overloaded
4	9042	The cushion lock is open
5	9052	The brake light is overloaded
6	9062	Low beam is overloaded circuit
7	9072	Fog lights is overloaded the way with yellow light
8	9082	Heated handlebar is overloaded circuit
9	9092	High beams is overloaded the way
10	90A2	The left light is overloadedn
11	90B2	The right light is overloaded
12	90C2	The left turn signal is overloaded
13	90D2	The right turn signal is overloaded
14	9003	Spotlights are wires short circuit
15	9023	Fog lamp white light wires short circuit
16	9033	The horn is wires short circuit
17	9043	Seat lock wires short circuit
18	9053	Brake light wires short circuit
19	9063	Short circuit in the low beam
20	9073	Fog lamp yellow light wires short circuit
21	9083	Heating handlebar wires short circuit
22	9093	Short circuit in high beams
23	90A3	The left light is wires short circuit
24	90B3	The right light is wires short circuit
25	90C3	Left turn signal swires hort circuit
26	90D3	The right turn signal is wires short circuit

## LCM key fault code

NO.	Fault codes	Description of the fault code
1	A001	KEY1 Channel - 【Channel】 Short circuit
2	A002	KEY1 Channel - 【Channel】 Open Circuit
3	A021	KEY1 Channel-【- Overtaking button】 Short circuit
4	A022	KEY1 Channel-【- Overtaking button】 Open Circuit
5	A031	KEY1 Channel-【- High beam button】 Short Circuit
6	A032	KEY1 Channel-【- High beam button】 Open Circuit
7	A101	KEY2 Channel--【Windscreen channel】 Short Circuit
8	A102	KEY2 Channel--【Windscreen channel】 Open Circuit
9	A111	KEY2 Channel--【Down /-Key】 Short Circuit
10	A112	KEY2 Channel--【Down /-Key】 Open Circuit
11	A121	KEY2 Channel--【OKKey】 Short Circuit
12	A122	KEY2 Channel--【OKKey】 Open Circuit
13	A131	KEY2 Channel--【Up /+Key】 Short Circuit
14	A132	KEY2 Channel--【Up /+Key】 Open Circuit
15	A141	KEY2 Channel--【Return to Key】 Short Circuit
16	A142	KEY2 Channel--【Return to Key】 Open Circuit
17	A151	KEY2 Channel--【Danger Warning Light Key】 Short circuit
18	A152	KEY2 Channel--【Danger Warning Light Key】 Open Circuit
19	A161	KEY2 Channel--【TCSKey】 Short Circuit
20	A162	KEY2 Channel--【TCSKey】 Open Circuit
21	A171	KEY2 Channel--【Cushion lock Key】 Short Circuit
22	A172	KEY2 Channel--【Cushion lock Key】 Open Circuit
23	A201	KEY3 Channel--【 Channel 】 Short Circuit
24	A202	KEY3 Channel--【 Channel 】 Open Circuit
25	A211	KEY3 Channel--【Right Turn Key】 Short Circuit
26	A212	KEY3 Channel--【Right Turn Key】 Open Circuit
27	A221	KEY3 Channel--【Steering Reset Key】 Short Circuit
28	A222	KEY3 Channel--【Steering Reset Key】 Open Circuit
29	A231	KEY3 Channel--【Left Turn Key】 Short Circuit
30	A232	KEY3 Channel--【Left Turn Key】 Open Circuit

# Troubleshooting

## LCM key fault code

Serial number	Fault codes	Description of the fault code
31	A241	KEY3 Channel--【Horn Key】Short circuit
32	A242	KEY3 Channel--【Horn Key】Open Circuit
33	A251	KEY3 Channel--【Light Key】Short circuit
34	A252	KEY3 Channel--【Light Key】Open Circuit
35	A301	KEY4 Channel--【 Channel 】Short circuit
36	A302	KEY4 Channel--【 Channel 】Open Circuit
37	A311	KEY4 Channel--【MODEKey】Short circuit
38	A312	KEY4 Channel--【MODEKey】Open Circuit
39	A321	KEY4 Channel--【Handlebar Heating Key】 Short circuit
40	A322	KEY4 Channel--【Handlebar Heating Key】Open Circuit
41	A501	KEY6 Channel--【 Channel 】Short circuit
42	A502	KEY6 Channel--【 Channel 】Open Circuit

Troubleshooting

Key's open circuit faulty will not show individual, If a KEY channel or the internal sense resistor (33K $\Omega$ ) of the KEY channel is not connected, it will directly alarm all open circuits in the channel .

## Storage methods

### Storage methods

If your motorcycle will not be used for a period of time, it requires special maintenance, which requires certain special materials, equipment, and techniques. For the above reasons, it is recommended that you have these maintenance tasks completed by our company's maintenance unit.

### Motorcycle

Thoroughly clean the motorcycle.

Park the motorcycle on a flat surface using the side stand.

Turn the handlebar to the left, long press the red power button on the handlebar to power off the entire vehicle, and the front lock will automatically lock.

### Fuel

Drain the fuel from the fuel tank into a container using a siphon or other appropriate method.

### Engine

1.Remove the spark plug, pour one tablespoon of new engine oil into each spark plug hole, reinstall the spark plug, and rotate the engine crankshaft several times.

2.Drain the engine oil completely and add new engine oil.

3.Cover the air filter intake port and muffler exhaust port with a cloth soaked in new engine oil to prevent moisture from entering.

### Battery

1.Remove the battery with reference to the battery section.

2.Clean the surface of the battery with neutral soapy water and remove rust from the terminals and wiring connectors.

3.Store the battery in a room above zero degrees Celsius.

### Maintenance

Use our company's dedicated charger to charge the battery every three months.

### Tires

Adjust the tire pressure to the specified pressure.

### Motorcycle surface

1.Spray rubber protectant on the surface of resin and rubber parts.

2.Spray anti-rust paint on the surface of parts without surface treatment.

3.Apply car wax to the painted surface.

# Maintenance and storage

## Re-enable the method

### Re-commissioning method

- Thoroughly clean the motorcycle.
- Remove the cloth covering the air filter intake port and muffler exhaust port.
- Drain the engine oil. Replace the oil filter and add new engine oil in accordance with the relevant content of this user manual.
- Remove the spark plug. Rotate the engine several times. Reinstall the spark plug.
- Reinstall the battery with reference to the battery section.
- Confirm that the motorcycle is properly lubricated.
- Perform the checks specified in the pre-driving check section of this user manual.
- Start the motorcycle in accordance with the relevant content of this user manual.

### Rust prevention

It is important to maintain the motorcycle carefully to avoid rust, so that the motorcycle will look like a new car after many years.

### Key points for rust prevention

Factors that cause rust damage: accumulation of salt from salted roads, dirt, moisture, chemicals. Damage to the painted surface by small stones or gravel, or scratches from collisions. Salted roads, sea breeze, industrial pollution, and high humidity environments can all cause rust.

### How to prevent rust

1. Clean the motorcycle at least once a month. Keep the vehicle clean and dry as much as possible.
2. Remove dirt from the motorcycle surface. Substances such as salt from salted roads, chemicals, asphalt, tree sap, bird droppings, and industrial emissions can damage your motorcycle. Remove these substances as soon as possible. If they are difficult to clean with water, use a cleaning agent. Follow the cleaning agent product instructions when using it.
3. Repair body damage promptly. Carefully inspect the painted surface of the motorcycle for damage. If any burrs or scratches are found, repair them immediately to avoid further damage. If the burrs and scratches penetrate the entire part surface, have it repaired by our company's designated maintenance unit.
4. Store the motorcycle in a dry and well-ventilated place. If you often wash the motorcycle in the garage and park it there, the garage will become very humid. High humidity will increase rust. If the air is not circulating, even in a high-temperature environment, a damp motorcycle will rust.

5. Cover the motorcycle. Avoid exposing the motorcycle to direct sunlight at noon, as this can cause discoloration of painted parts and plastic parts, and fading of the instrument panel. Using a high-quality, breathable cover can prevent ultraviolet radiation from the sun and reduce the deposition of dirt and air pollution on the motorcycle. Our company's dealers can help you select a suitable cover for your motorcycle.

## Cleaning the motorcycle

### Clean the motorcycle in accordance with the following guidelines:

Regular and thorough cleaning of the vehicle not only keeps it looking bright but also improves its regular performance and extends the service life of many components. Cleaning, washing, and polishing also give you more opportunities to check the condition of your vehicle frequently. Be sure to clean the vehicle after riding by the sea or in the rain, as salt and moisture can corrode metal parts.

### CAUTION

• In cold weather, when roads may be de-iced with salt, it is important to thoroughly clean the vehicle to remove road salt and avoid corrosion. Wheel spokes, bolts/nuts, and other unpainted metal parts are particularly susceptible to corrosion from road salt. After cleaning and drying the vehicle, apply anti-corrosion products to all vulnerable parts.

### Cleaning steps

Wait for the engine, muffler, brakes, and other high-temperature components to cool down before cleaning.

1. Rinse the motorcycle thoroughly with a low-pressure hose to remove loose dirt.
2. If necessary, use a sponge or soft towel dipped in mild detergent to remove dirt.

## Maintenance and storage

- Be particularly careful when cleaning the windshield, headlight lens, panels, and other plastic components to avoid scratches. Do not allow water to directly enter the air filter, muffler, and other electrical components.

3. Rinse the motorcycle thoroughly with plenty of clean water and dry it with a clean soft cloth.

4. After drying the motorcycle, lubricate all moving parts.

- Ensure no lubricating oil splashes onto the brakes or tires. Contaminated brake discs, brake pads, brake drums, and brake shoes will have significantly reduced braking performance, which may cause accidents.

5. Immediately lubricate the drive chain after cleaning and drying the motorcycle.

6. Waxing can prevent corrosion.

- Avoid using products containing strong detergents or chemical solvents. These substances can damage the motorcycle's metal parts, paint, and plastic components.

- Do not wax tires and brakes.

- If your motorcycle has parts with a matte paint finish, do not wax or polish the matte paint.

### CAUTION

- Do not use alkaline or acidic cleaning agents to clean the motorcycle, and do not use gasoline, brake fluid, or other solvents that may damage the motorcycle. Clean only with a soft cloth and warm water with a neutral cleaning agent.

- Avoid cleaning the motorcycle's cover paint with the following cleaning agents:

- Engine exterior cleaner (engine degreaser), range hood cleaner, bathroom cleaner, carburetor cleaner, chain cleaner, and cleaning products containing bleach. Try to avoid contact with brake fluid, strong acids, and alkalis to prevent corrosion.

### DANGER

- Driving a motorcycle with wet brakes is very dangerous. Wet brakes cannot provide the same braking force as dry brakes. This can cause accidents. After cleaning the motorcycle, test the braking system at low speed. If necessary, operate the brakes several times to dry the brake pads.

## Cleaning precautions

### Follow these guidelines when cleaning:

1. Do not use a high-pressure water gun:

- High-pressure water can damage moving parts and electrical components, making them irreparable.
- Moisture at the air intake may be sucked into the throttle body or air filter.

2. Do not rinse the muffler directly with water:

- Water entering the muffler may cause failure to start and rusting of the muffler.

3. Dry the brakes:

- Water will reduce braking performance. After cleaning, operate the brakes intermittently at low speed to help dry them.

4. Do not directly under the seat cushion with water:

- Water entering the storage box under the seat cushion can damage your documents and other items.

5. Do not rinse the air filter directly with water:

- If the air filter gets wet, the engine may not start.

6. Do not rinse directly near the headlight with water:

- After cleaning or driving in the rain, the inner lens of the headlight may fog temporarily. This will not affect the function of the headlight.
- However, if you find a large amount of water or ice accumulated inside the lens, have it inspected by an authorized ZONTES flagship store or dealer.

7. Do not wax or polish matte paint surfaces:

- Clean matte paint surfaces with a soft cloth or sponge, plenty of water, and mild detergent. Dry with a clean soft cloth.

### Follow these guidelines after cleaning:

1. Dry the motorcycle with a towel or absorbent cloth.
2. Spray anti-corrosion agent on all metal parts. **WARNING!** Do not apply anti-corrosion agent or oil spray on the seat cushion, handlebars, footrests, or tires. Otherwise, these parts may become slippery, leading to vehicle loss of control. Before operating the vehicle, thoroughly clean the surface of these parts.
3. Maintain rubber parts, plastic parts, and unpainted plastic parts with suitable maintenance products.

## Maintenance and storage

4. Wax all painted surfaces with non-abrasive wax or vehicle-specific spray.
5. After cleaning, start the engine and let it idle for several minutes to dry any residual moisture.
6. If the headlight lens fogs, start the engine and turn on the headlight to remove the moisture.
7. Store or cover the vehicle only after it is completely dry.

### WARNING

• Contaminants remaining on the brakes or tires may cause vehicle loss of control.

Ensure there is no lubricating oil or wax on the brakes or tires.

• If necessary, clean the tires with warm water and a neutral cleaning agent.

• If necessary, clean the brake discs and brake pads with brake disc cleaner or acetone.

• Before riding at higher speeds, test the braking performance and turning characteristics.

---

### Exhaust pipe and muffler

The exhaust pipe and muffler are made of stainless steel but may become dirty due to mud or dust.

Remove mud or dust with a damp sponge dipped in kitchen liquid abrasive, then rinse thoroughly with clean water. Dry with a soft towel.

If necessary, remove burn marks with a fine-grained commercial compound, then rinse in the same way as removing mud and dust.

If the exhaust pipe and muffler are painted, do not use commercial abrasive kitchen cleaners. Clean the painted surface of the exhaust pipe and muffler with a neutral detergent. If you are unsure whether the exhaust pipe and muffler are painted, have them inspected by an authorized ZONTES flagship store or dealer

### CAUTION

• Although the exhaust pipe is made of stainless steel, it may still rust. Once rust is found, remove all traces and dirt immediately.

---

### Aluminum components

Aluminum can be corroded when in contact with dirt, mud, or salt. Clean aluminum parts regularly and follow these guidelines to prevent scratches:

- Do not use hard brushes, steel wool, or other abrasive cleaning tools.
- Do not drive or scrape on the curb.

## Panels

Follow these guidelines to prevent scratches and damage:

- Clean gently with a sponge and plenty of water.
- Clean stubborn dirt with diluted detergent and rinse thoroughly with plenty of water.
- Avoid getting gasoline, brake fluid, or detergent on the instrument panel, windshield, panels, or headlight.

## Windshield

Clean the windshield with a soft cloth or sponge and enough water. (Avoid using detergents or any type of chemical cleaner on the windshield.) Dry with a clean soft cloth.

### CAUTION

- To avoid possible scratches or other damage, clean the windshield only with water, a soft cloth, or a sponge.

For heavily soiled windshields, clean with diluted neutral detergent, a sponge, and enough water. Ensure all detergent is rinsed off. (Detergent residue may cause the windshield to crack.)

- If scratches cannot be removed, replace the windshield as they may obstruct clear visibility.
- Keep battery electrolyte, brake fluid, or other chemical solvents away from the windshield and glass components. They can damage plastic.

## Transportation

Check the motorcycle in accordance with the pre-driving check section.

The fuel must be drained before transporting the motorcycle. Fuel is highly flammable and may explode under certain conditions. When draining, storing, or refueling fuel, strictly prohibit open flames. Ensure the engine is stopped and operate in a well-ventilated area.

Fuel Draining Steps:

1. Stop the engine and turn off the electric door lock switch.
2. Drain the fuel from the fuel tank into a suitable container using a siphon or other appropriate method.

### CAUTION

- When transporting the motorcycle, be sure to drain all fuel from the fuel tank. Transport the motorcycle in a normal driving position to prevent fuel leakage.

# Specification sheet

## Identification numbers

The frame and engine numbers are unique identifiers for your motorcycle and are required for registration. These numbers enable authorized dealers to provide better service when ordering parts or requesting specific maintenance. Please record these numbers and store them in a secure location.

Specification sheet



Frame number

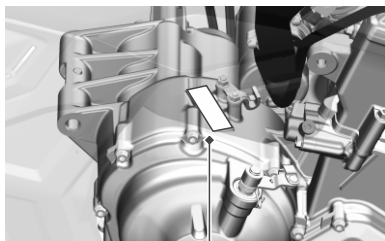

Engine number

## Nameplate

- This nameplate is made of a special material with tamper-evident properties and is a one-time-use product. Do not damage or remove it.
- This nameplate bears authoritative certification. Do not privately reproduce or print it.
- Do not clean the nameplate with corrosive liquids.
- Do not spray the nameplate with a high-pressure water jet.

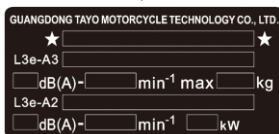
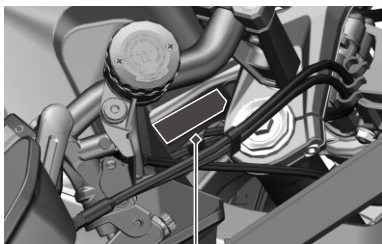

## Dimensions and curb weight

### 19-inch/Basic version(storage box)

Length	2265mm
Width	960mm
Height	1510/1603mm
Wheelbase	1550mm
Ground clearance	190mm
Seat height	830mm
Dry height	215.5kg
Curb weight	236kg

### 19-inch/Bumper+Three-box bracket

Length	2315mm
Width	960mm
Height	1510/1603mm
Wheelbase	1550mm
Ground clearance	190mm
Seat height	830mm
Dry height	220.5kg
Curb weight	241kg

### 21-inch/Basic version(storage box)

Length	2305mm
Width	960mm
Height	1525/1618mm
Wheelbase	1565mm
Ground clearance	205mm
Seat height	845mm
Dry height	215.5kg
Curb weight	236kg

### 21-inch/Bumper+Three-box bracket

Length	2355mm
Width	960mm
Height	1525/1618mm
Wheelbase	1565mm
Ground clearance	205mm
Seat height	845mm
Dry height	220.5kg
Curb weight	241kg

# Specification sheet

## Engine-Version 1

Three-cylinder, vertical,  
four-stroke, water-cooled, 699cc

Number of cylinders	3	
Cylinder diameter	70.0mm	
Stroke	60.6mm	
Displacement	699mL	
Compression ratio	13.0:1	
Start mode	Electric start	
Lubrication method	Pressure splash type	
Power	70.0kW	
Clutch	Wet multi-piece	
Transmission	Six-speed wheel shifting	
The primary wheel ratio	1.775	
Gear ratio	First gear	3.000
	Second gear	2.250
	Third gear	1.789
	Fourth gear	1.500
	Fifth gear	1.304
	Sixth gear	1.160
Drive form	Chain	
Economical fuel consumption	5.0L/100km	
Top speed	195km/h	

## Engine-Version 2

Three-cylinder, vertical,  
four-stroke, water-cooled, 699cc

Number of cylinders	3	
Cylinder diameter	70.0mm	
Stroke	60.6mm	
Displacement	699mL	
Compression ratio	13.0:1	
Start mode	Electric start	
Lubrication method	Pressure splash type	
Power	35.0kW	
Clutch	Wet multi-piece	
Transmission	Six-speed wheel shifting	
The primary wheel ratio	1.775	
Gear ratio	First gear	3.000
	Second gear	2.250
	Third gear	1.789
	Fourth gear	1.500
	Fifth gear	1.304
	Sixth gear	1.160
Drive form	Chain	
Economical fuel consumption	5.0L/100km	
Top speed	158km/h	

## Chassis system

Steering angle	42°
Tire specifications	
	(19-inch)
Front tire	120/70R19
	(21-inch)
	90/90-21
	(19-inch)
Rear tire	170/60R17
	(21-inch)
	150/70R18
Electrical system ignition method	Inductive discharge ignition
Spark plug model	BN8RTIP-8
Battery specification	12V, 6Ah
Fuse specification	10A/15A/25A

## Capacity

Effective Fuel Tank Capacity	22L
Engine Oil Capacity	4000mL
Engine Oil Replacement Capacity (with oil filter replacement)	3400mL
Engine Oil Replacement Capacity (without oil filter replacement)	3000mL

## Lamp power

Low beam	24W
High beam	28W
Front position light	1.4W/2.8W
Front turn signal	2W
Rear position light	2W/4W
Brake light	2.5W
License plate light	0.9W
Rear turn signal	3.5W
Front fog lamp	6.6W

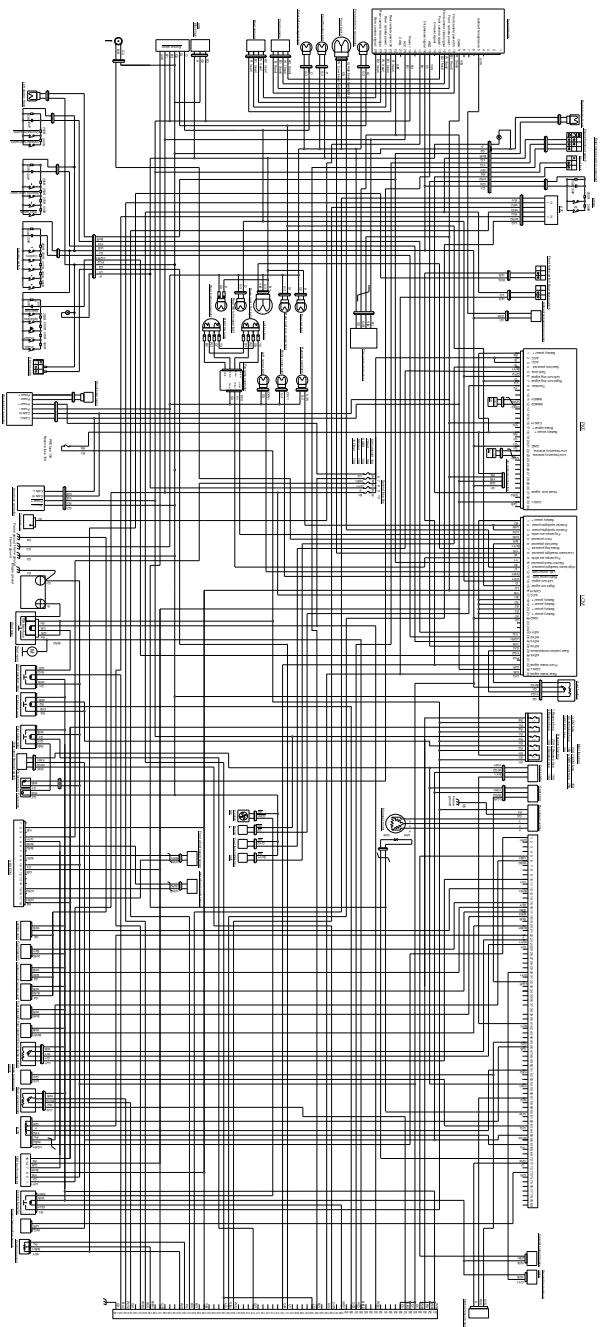

ZT703-F(ETC) CIRCUIT schematic English version

ETC



[WWW.ZONTES.COM](http://WWW.ZONTES.COM)