

C.2
MOTORCYCLE MANUAL

Preface

Thank you for choosing the ZONTES brand motorcycle. We design, test and manufacture this type of motorcycle for you with advanced technology to provide you with happy, interesting and safe driving. When you are completely familiar with the essentials in this manual, you will feel that driving a motorcycle is an exciting sport and you will feel the real pleasure of driving.

For your driving safety, please pay attention to the following items:

- Be sure to read this User's Manual carefully.
- Refer to the recommendations and procedures in this manual
- Please carefully read the safety tips pasted on the motorcycle body and written in this manual.

This User's Manual provides an overview of the correct repair and maintenance methods for motorcycles. At the same time, ZONTES Dealership has professionally trained technicians with complete tools and equipment to provide you with high-quality maintenance services at any time.

The vehicle information in this User's Manual is the latest production information before printing. Guangdong TAYO Motorcycle Technology Co., Ltd. reserves the right to modify the contents and design of this manual at any time, and will not assume any responsibility for this.

The contents of this User Manual are updated quickly, and the official website shall prevail. The PDF file of this manual can be downloaded from the official website.

The vehicle shown in this User's Manual is for reference only, and the actual situation is based on your actual vehicle.

Guangdong TAYO Motorcycle Technology Co., Ltd. reserves the right of final interpretation of this User's Manual.

No part of this manual may be reproduced or copied without permission.

Preface

Safety precautions:

The safety of you and others is very important. Please obey the traffic rules and drive safely.

In order to help you drive safely, our company provides detailed operation instructions and other relevant information on the body label and this manual to prevent you or others from being exposed to potential dangers.

The standard signal words in this manual are: Danger, Warning and Caution.

The following signal words and signs appear in this manual and on your vehicle. When these words and signs appear, they mean that your safety is at stake. Please familiarize yourself with the meaning of these signs before reading this manual.



Failure to observe the danger signs could result in serious injury or death.



Failure to observe the warning signs may result in serious injury or death.



Failure to observe the cautionary instructions may result in damage to the motorcycle and property.



Catalog

Catalog	2	Instrumentation	25
Information for Users	4	Instructions for Fuel, Oil, Coolant and Gear Oil	32
Instructions	4	Fuel	32
Modification	4	Engine oil	32
Safe driving instruction	4	Engine coolant/antifreeze	32
Inspection before driving	5	Distill water for coolant/antifreeze -	32
Vigilance in driving in rainy weather -	5	Coolant/antifreeze	33
Speed limit	5	The volume of coolant/antifreeze --	33
Product Configuration Description --	5	Change the coolant/antifreeze -----	35
Driving tips	6	Inspection and Maintenance	36
Starting of the engine	6	First Inspection	36
Driving	7	Pre-driving inspection	36
Break-in of the new vehicle	10	Keep proper wheel pressure	36
Numbering position	11	Maintenance schedule	37
Installation locations of spare parts ---	13	Scheduled Maintenance Sheet	39
.....	13	Fuel Tank Removal	42
Handlebar control system	14	The steps to remove the fuel tank are -	42
Shift lever	16	42
Rear brake pedal	16	Fuel tank inspection and repair	43
Rear shock absorber spring	17	Tool kit	44
Side parking bracket	17	Lubricating point	45
Front footrest position adjustment -	18	Battery	46
PKE operating instructions	20	Removing the battery	46
Use of inductive key	20	Instructions for using the battery ---	48
PKE working	21	Charger instructions	50
Turn on the PKE	21	Air filter cartridge	51
Turn off the PKE	22	Spark plugs	52
Non-electric induction start mode -	23	Removing the spark plug	52
PKE Host buzzer sound	23	Disassembly the spark plug	52

Catalog

Checking the spark plugs -----	53	Tires -----	69
Installing the spark plug -----	53	Tire pressure and load -----	69
Install spark plug -----	53	Tire storage -----	70
Engine oil -----	54	Front-wheel disassembly -----	71
Checking the oil level -----	54	Rear Wheel Removal -----	72
Changing the oil -----	54	Lighting & Lamps -----	74
Oil filter -----	56	Headlight bulb replacement -----	74
Clutch cable clearance -----	58	Headlight Beam Height Adjustment ---	74
Large adjustment -----	58	-----	74
Clutch cable clearance -----	59	Fuses -----	75
Fuel Evaporation Pollutant Control		Troubleshooting -----	76
System -----	59	EFI Precautions -----	79
USB port -----	60	Adding electrical parts -----	83
Drive chain -----	61	Storage Methods -----	85
Brake system -----	65	Inspection after cleaning -----	88
Braking fluid -----	66	Cleaning the motorcycle -----	90
Brake pads -----	66	Specification sheet -----	92
Front wheel -----	67	Wiring diagrams -----	94
Rear wheel -----	67		
Rear brake pedal adjustment -----	68		

Information for Users

There are all kinds of accessories on the market it can be assembled on your motorcycle, and we cannot directly control the market quality and applicability of accessories. The inapplicable accessories will endanger the safety of the riding personnel. The selection of accessories and installation, therefore, must be especially careful. Though we can't examine the applicability of accessories for sell on the market, but your distribution unit can help you to choose high quality accessories on the market, and can be installed correctly.



- **Accessories installed incorrectly or modified motorcycles will change handling of the motorcycle, this will cause an accident. Never use inappropriate accessories, to ensure that parts are installed correctly. All accessories and parts should use part of the company original.**
- **You should be properly installed accessories and spare parts, If you have any questions, please contact the company's authorized dealership or special maintenance shop.**

Instructions

Windshield, chair back, saddle bags, luggage, etc., are all laid accessories, easy to cause the instability of driving. Especially in the side wind or with large vehicles encountered. If the accessories installed wrong or poorly designed accessories, would endanger the safety.

Additional electrical accessories can make the electrical system overload, serious overload may damage the wiring, make the engine stalling when driving, and even destroy vehicles.

When transporting goods, they should be fixed in the low position as far as possible close to the motorcycle. Fixed goods incorrectly can lift the center of gravity which is very dangerous. It can make the motorcycle hard to control. The size of the goods will affect the air drag and motorcycle maneuverability. Please balance the left sides of the motorcycle, and fixed the goods.

Modification

Motorcycle modification or removal device cannot guarantee the original motorcycle driving safety, and it is illegal. The user will lose the rights of quality guarantee if they modify the motorcycles.

Safe driving instruction

Driving a motorcycle is a very interesting and exciting sport activity. It also requires special precautions to ensure the safety of drivers and motorists. Preventive measures are as follows:

Inspection before driving

Carefully read the instructions in the "Inspection before driving" section, and check each item according to the instructions, do not forget, this can ensure the safety of the driver and passengers. Your driving skill and mechanical knowledge, is the foundation of safe driving. First practice at where there are fewer motorcycle, until you can fully familiar with the mechanical performance and operation method of motorcycle. Remember that! Practice makes perfect.

Vigilance in driving in rainy weather

At any time drive within the scope of your own skilled. Know your skills limit and not to be reluctant so as to avoid accidents.

Vigilance in driving in rainy weather

Pay extra attention to driving on cloudy and rainy days, and keep in mind that the braking distance is twice that of sunny days. When driving, avoid road marking paint, manhole covers, and oily roads to avoid slippage. Drive with extreme caution over railroad crossings, iron fences and bridges. If you cannot clearly judge the road conditions, you should slow down.

Speed limit

Do not let the vehicle speed too high at any time, and do not let the engine rev too high to avoid accidents.

Product Configuration Description

The motorcycles in this manual have many configurations. The illustrations in this manual can only represent one or several configurations, not all configurations. The specific configuration should be subject to the actual object.



• If the parts or goods added to the locomotive change the weight distribution of the locomotive, it may have a negative impact on stability and operation. In order to avoid the possibility of an accident, please do not overload and modify it privately.

Driving tips



·As you drive the motorcycle for the first time, we suggest you had better look for practice on the un-public road, until you are familiar with this motorcycle control method.

· Driving with only one hand is the most dangerous, we should driving in both hands firmly in the grip and both feet on the foot. · No matter any situation, no hands are allow to be away from the line.

· When turning, try to lower the speed to safe speed.

Road surface is moist and smooth, tire friction will be small, braking ability and the ability to turn the naturally decrease, so you must lift the speed.

· Horizontal wind is usually the most likely to happen in the tunnel, valleys or large vehicles from behind when overtaking. You must be calm and lower your speed.

· Obey the traffic rules and speed limits

Starting of the engine

When you start the system without key, all the motorcycle will be connected automatically. Check whether the engine turn off switch is in the position of \odot . At this moment your motorcycle is in the neutral position, the neutral light will light up on the dashboard.



·This motorcycle equipped with ignition circuit and the starter circuit interlock switch. Only under the condition of the following the engine will start:

1.Transmission is under neutral gear, hold the clutch handle.

2.Transmission is not under neutral gear,side stand is packed up and you hold the clutch handle.

· Dumping of sensor when the motorcycle is overturned, will cut off the power and stop the oil supply, and make the motorcycle stall, and fault indicator will light up. Motorcycle starting again, you need to turn off the ignition switch, after waiting for 1 minute, reopen the ignition switch, and starting the engine.

Driving tips

When the engine is in cold machine status:

1. Pack up the side stand.
2. Throttle control handle is on idling position.
3. First pinch the clutch and then press the electric start button  to start.

When the engine is in cool machine status and hard to start:

1. Pack up the side stand.
2. Turn the throttle 1 / 8th opening, and at the same time pinch the clutch before pressing the electric start button  to start.
3. After starting the engine, keep the engine turning to fully preheated.
4. When after several times that the engine is hard to start, it is most likely that the cylinder submerged. In the case, you have to do the clear cylinder process: open the acceleration entirely, press the starting button for 3 seconds.



· The colder is the weather, the longer time the engine needs to preheat. After fully preheat, you can reduce the engine wear and tear.

When the engine is in hot machine status

1. Pack up the side stand.
2. Throttle control handle is on idling position.
3. First pinch the clutch and then press the electric start button  to start.

When the engine is in hot machine status and hard to start

1. Pack up the side stand.
2. Turn the throttle 1 / 8th opening, and at the same time pinch the clutch before pressing the electric start button  to start.
3. When after several times that the engine is hard to start, it is most likely that the cylinder submerged. In that case, you have to do the clear cylinder process: open the acceleration entirely, press the starting button for 3 seconds.



· When starting the hang gear in neutral, throttle back to bottom, form a habit of holding the clutch handle before starting. Avoid-error, when it is starting, moving forward immediately.

· When the motorcycle is starting, you must hold the clutch handle, or make the engine in the neutral condition, otherwise it can't start, don't forget to pack up side racks at the same time.

· Do not start motorcycle without fuel and engine oil.

Driving

Pack up the main stand, hold the clutch handle, just wait a moment, hit the hang first gear shift lever: step on the gas and slowly release the clutch handle gently, the motorcycle will start.

If you want to get to the next higher gear, speed up first, and then close the throttle, hold the clutch handle at the same time, the shift lever stepped down, hanging in the second gear. And then loose the clutch handle gently, gently step on the gas. In accordance with the main point to gradually shift can reach a top speed of gear.



· This motorcycle is configured with side racks and ignition interlock switch. When we set up side racks, it will range from neutral to other gears, the engine will stop running.



· When going downhill, we will not closed the ignition switch or engine flameout switch. Otherwise, it will reduce the life of the catalyst in the muffler.

Use the transmission system

The transmissionsystem can make the engine running smoothly in the normal speed range. Variable speed ratio is carefully selected for the engine performance. Drivers shall select the most appropriate gear according to driving conditions, and never use low-grade in high speed driving. In any time, don't use the method of half clutch to control speed. Before changing in low level gear, lower the speed or increase the speed of the engine. before hanging into the high-end gear, improve the speed or reduce the engine speed.

Riding uphill

When climbing steep hills, motorcycles will have the phenomenon of underpowered slowdown. You should put the low gear, let the engine operates within the scope of normal power. Then shift should be quickly, to avoid the motorcycle to slow down too much.

When going downhill, we can use the engine to assist braking resistance, as long as the gear into a lower gear. If the brake to be continuous using, it will overheat, and reduce the braking ability.



· When going downhill, you will not close the ignition switch or engine flameout switch, so as not to reduce the service life of catalyst in the muffler.

Driving

Braking and parking

- (1) Turn the throttle control handle forward, and make the throttle fully return.
- (2) Brake by using the front brake controller and rear brake pedal at the same time.
- (3) When the speed is low enough, you can change it to low level gear so as to reduce the speed.
- (4) Hold the clutch handle (to clutch off), put the gear into a gap position and then stopped completely. After having into the gap position, the gap indication light is lit.
- (5) If a motorcycle with a side stand is going to park in gentle slope road, you should hang gear into the low level, as far as possible to get the motorcycle started up hill side, to avoid overturned because of side racks rotation. However, when restart, you must hang the files back to the neutral position.
- (6) Turn the turn off switch on the right handle bar to the turn off gear position, the engine will stop.
- (7) Turn the handle bar to the left for most extent, press the “” button for 2-3 seconds, the handle bar will be locked and the electricity will cut off completely.
- (8) Swing the handle bar to make sure the handle bar is locked.



· High speed will extend the braking distance accordingly. Make sure the front vehicle or object to have proper distance with you to make your motorcycle braking. Otherwise it may cause collision.

· Use only front and rear brake is very dangerous, the braking method causes skid and out-of-control. In the wet pavement as well as turn place, be careful gently use the braking system. In the uneven road surface or smooth roads, to have emergency braking, you can make the motorcycle out of control.

· Emergency braking when the motorcycle is turning can make the motorcycle out of control. In this case, brake before the turning to reduce speed.

· When the engine is working or just stalling soon, the temperature of the muffler is high, please do not touch to prevent burns.

· Only use rear brake to brake will make brake system accelerated wear and tear so that the braking distance is longer and longer.



· If you use other anti-theft lock, such as u-lock, brake disc, chain lock anti-theft lock; you have to remove the anti-theft lock before driving.

Break-in of the new vehicle

The correct new running-in can prolong the service life of the motorcycle, it can also give full play to the performance of the new motorcycle. Below is a list of running in right way.

Recommended maximum engine speed

First 500 kilometers	below 5500 turns/minute
Up to 1500 kilometers	below 8000 turns/minute
Over 1500 kilometers	below 9800 turns/minute

Maximum RPM recommended

The gear and speed of the engine should be changed from time to time, and do not run continuously in a certain gear and speed. During the run-in period, the accelerator can be appropriately increased to make it fully run-in.

Running-in of tires

Like engine running-in, the adaptation of the new tires need to be correct to ensure the best performance. In use within the first 150km new tires, we should gradually increase the turning Angle to connect the ground surface in order to achieve the best performance of the tire. In the use of new tires within the first 150km, we should avoid nasty acceleration, a sharp turn, and emergency braking.

 **DANGER**

- If the tires are not well run in, it will cause the tires to slip and lose control. After changing tires, drive with extreme caution. Use the tires correctly according to the contents of this section, and avoid sharp acceleration, sharp turns and sudden braking during the first 150 kilometers of using the tires.

Avoid riding constantly under low RPM

In fixed (light load) under operation at low speed, it will make the parts wear and bad matching. As long as no more than recommended throttle opening (no more than 3/4 of the opening of the throttle), it can make the engine speed under various rotational speed. However, during the period of the first 500km, it should not be more than three quarters of the throttle opening.

Let the engine oil cycling

No matter in hot or cold machine status, before starting, you should let the engine had good idle running time in order to make the oil flow to all lubrication part.

Numbering position

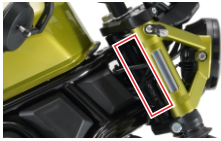

①

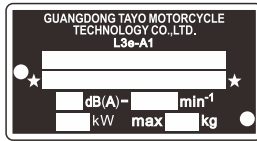

②



③

The Vehicle Identification Code and the engine number are used for the registration of the motorcycle. When ordering accessories or commissioning special services, the number enables the distributor to provide you with better service.

- ① The vehicle identification code is engraved on the frame under the seat seat,
- ② The 3C nameplate is fixed at the bottom of the front riser of the frame.
- ③ The engine number is embossed on the right crankcase.

Vehicle identification number:

Engine number:

Muffler care and maintenance

This motorcycle muffler with catalyst can effectively reduce the operation process of motorcycle emissions of harmful substances into the atmosphere. To make the device work effectively, please refer to “maintain” the preventive maintenance in the section table.

In order to improve the service life of the muffler, and avoid faults caused by not-normal-use and maintenance of the mufflers rust, catalytic conversion efficiency decrease, please be sure to comply with the following items:

- It is forbidden to hit the accelerator at high speed in place for a long time
- It is forbidden to drive in heavy-load low-speed for a long time.
- It is forbidden to add anti-rust oil or engine oil to the muffler.
- It is forbidden to directly flush the muffler with cold water when the motorcycle is hot.
- It is forbidden to slide when shut off.
- It is forbidden to use inferior oil.
- Use unleaded gasoline.
- Keep clear the dirt of muffler to the rear and the surface.

Numbering position

- Keep the engines running on good condition, regular maintenance and inspection. Avoid failure. Leads to engine combustion exhaust gas in the exhaust pipe to cause secondary combustion catalyst sintering failure.
- Installing a muffler, be sure to properly installed muffler gasket.
- If you need to dismantle oxygen sensor, be sure to use the right tools, and be sure to stay muffler outfit after cooling to room temperature.
- When installing the muffler decorative cover, be sure to install asbestos anti-hot pad at each screw point to avoid the muffler burning the decorative cover or causing fire risks in the high temperature.



- Please pay attention to the following items and similar items.
- Any violation may cause damage to parts or vehicles, or even casualties of riders.
- When driving, the side parking frame must be stowed to prevent the vehicle from overturning when turning, causing casualties to the riders.
- When driving, you must check whether the braking system is working properly. If there is a problem, please repair it immediately.



- Non-professionals should not unplug the fuel pipe to discharge the fuel, so as not to encounter open flames and damage the vehicle; do not let the muffler of the motorcycle contact foreign objects to avoid fire, and the use and storage environment of the motorcycle must not have fire hazards.
- When vehicle maintenance needs to replace parts, be sure to use the company's genuine parts, use non-genuine parts, especially electrical parts, which may damage the motorcycle or even burn the vehicle
- Please do not arbitrarily add accessories, especially electrical components, if the wiring is improper or the electrical load is too large, the vehicle may be burned.

Installation locations of spare parts

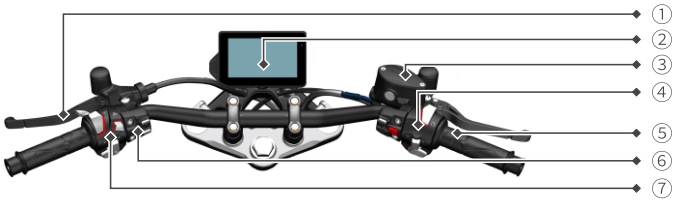

- ① Clutch lever
- ② Speedometer
- ③ Front disc brake oil cup
- ④ Right handle switch
- ⑤ Throttle
- ⑥ Left sub handle switch
- ⑦ Left handle switch



- ⑧ Rear brake
- ⑨ Front foot pedal
- ⑩ Rear disk
- ⑪ Side stand
- ⑫ Gear shift rod
- ⑬ Pedal Front disk brake

Handlebar control system

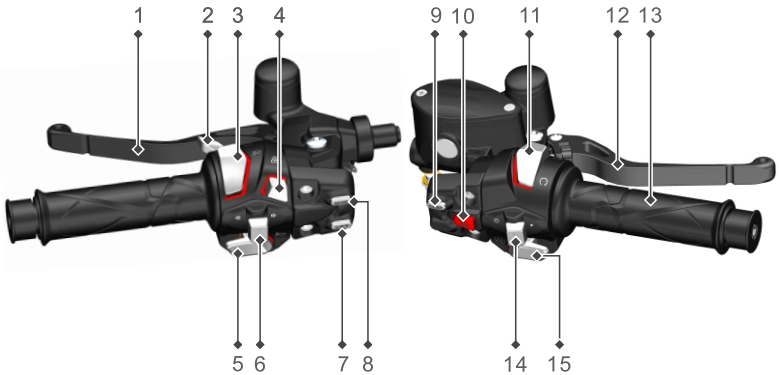



1. Clutch controller

When starting the engine or shifting gears, hold the handle to separate the clutch discs to cut off the power transmission.

2. Overtaking warning lights

When speeding up, press the button warning the cars in front or behind.

3. Dimmer switch high beam&low beam operation

When the dimmer switch on  position, the distance light is flashing. At the same time on the surface of the dashboard in light is lit will switch to  dipped headlight will be turn on and distance light is turn off. At the same time the high beam indicator on the dashboard surface lights up. When the switch is changed to , the low beam lights up.



4. Danger warning button

Press the button, the four lights are flashing, and warned nearby vehicles to pay attention to the safety.

5. Horn button

Press the button, the horn will ring.

6. Turn signal operation

When turn the switch to the left , the left turn light is flashing. When turn the switch to the right , the right turn light is flashing. The indicator light on the instrument surface also flashes at the same time.



· Whenever the road before changing lanes or turning, we must get into the habit of starting turn signals first. When gear changing lanes or turning is finished, they must be turn off.

Handlebar control system

7. MOD: Select the next (Move the cursor to select the option).

8. SET: Enter the main menu/confirm the option.

9. Cushion switch lock

When the engine does not start, when the cushion is locked, press the "SEAT" button, and the cushion lock will rise white.

10. Red power-on button

When the host is in the sleeping version, press the "⏻" button in short time to wake up the host. After detecting the response signal of the key and the signal of the handle bar lock, the whole vehicle will "starting" up. Press the "⏻" button in long time, the host will enter into sleep version, and the whole vehicle will be shut down.

11. Engine flameout switch

This switch is installed on the right hand switch assembly, is a kind of wave plate card, shaft in wave plate center. Dial in  position, the circuit connected, the motor can start.

If the switch in  position, starting circuit completely cut off, the motor can't start. It's an emergency way to shut down the switch.



When continue starting the engine, consecutive start time not more than five seconds at a time. Because a large number of start can make some abnormal heating to circuit and start motor. If you still can't start it a few time, you should stop and check the oil supply system and start the circuit system. (please refer to "troubleshooting" section.)

12. Front brake controller

When braking the front wheel, hold the brake handle on the right side. When braking the front wheel, we must grip on the right side of the front wheel brake. Because using the vehicle hydraulic brake disc, the brake holding force doesn't need to be large. When you hold front brake handle, brake lights will light up automatically.

13. Throttle control handle

Throttle control handle is used to control the engine rotating speed. When turn towards to the user's side is acceleration; On the other hand, turn towards to the opposite user's side is reduction.

Handlebar control system

14. Light switch

 Position: When the engine is working, the left and right hand switches backlight, front light, front position light, rear position light, and nameplate light are all on together.

● Position: front position light, rear position light and nameplate light are all on together.

15. Electrical starting button

Press this button to turn on the start-up circuit. When starting, you must set the gear position to the neutral position, confirm that the engine flame-off switch is in position, and hold the clutch handle to ensure safety.



· If the seat is not installed into position, the seat will glide which and will lead to the driver to lose control of the motorcycle. Make sure the seat cushion is locked in the correct position.

For details of the operation of MOD button and SET button, please refer to the main menu of the meter.

Shift lever

The motorcycle is equipped with 6 gear transmission. Down pedaling or up lifting the lever can switch gears. Afterwards, the lever will return to original position so as for subsequent gear shifting. Before shifting to lower gear, please reduce the speed or increase the RPM. Before shifting to higher gear, please increase the speed or reduce the RPM. Hence unnecessary wearing on transmission components and rear tire can be prevented.



· When the gear is in the neutral position, the neutral position indicator light is lit, please slowly release the clutch handle, to confirm whether really is in the neutral position.

Rear brake pedal

When press on the rear brake pedal, rear wheel brake will work, brake lights up at the same time.

Rear shock absorber spring

The rear shock absorber's spring is adjustable according to the will of the driver, the loading condition and road condition. The adjusting method is non-polar adjustment. You only need to stop the motorcycle with the side stand. And then you turn the spring adjustment to the needed position. The rigidity will decrease when we adjust it down; the rigidity will increase when we adjust it up.

Side parking bracket

When you are using the side stand, the side stand turn off switch will cut off the power if you don't hold the clutch handle and the shift level is on idle condition.

Shift lever

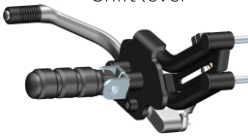

Rear brake pedal

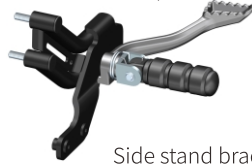

Rear shock absorber spring

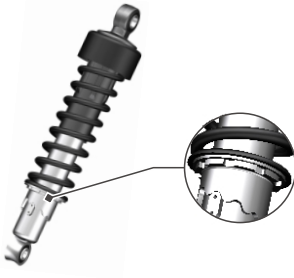

Side stand bracket



Front footrest position adjustment

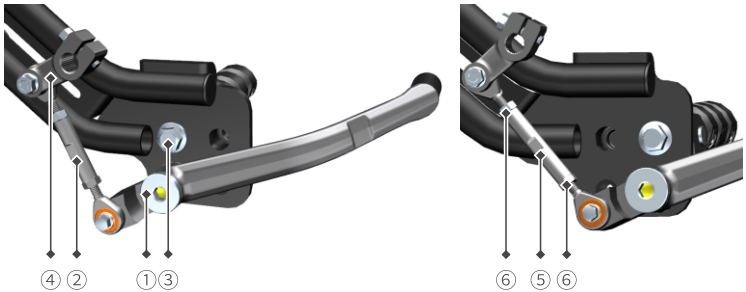

A. Adjusting the front left pedal position

Tools: 8# hexagonal socket, 14# plum wrench, 8# open-end wrench, 10# open-end wrench

1. Use 8# hexagonal socket to remove the M10 axle position bolt ①.
2. Use 8# and 10# open-end wrenches to remove the adjusting screw ②.
3. Remove the M10×25 bolt ③ with 14# plum wrench.
4. Install the front left pedal to the front position and tighten the M10×25 bolt ③.
5. Install the shift lever to the front position and tighten the M10 axle position bolt ①.
6. Rotate the spline rocker arm ④ clockwise by 1 or 2 teeth, replace the longer adjusting screw (in the accompanying accessories) ⑤, screw in the threads at both ends as long as possible, adjust the shift lever to the appropriate height, and tighten the adjusting screw lock nut ⑥.

Front footrest position adjustment

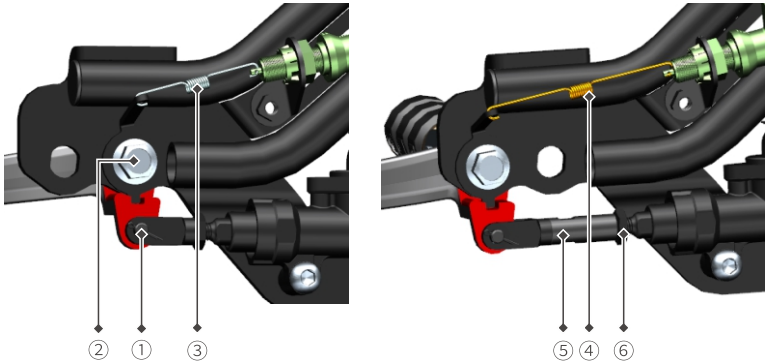

B.Adjusting the front right pedal position

Tools: 14# plum wrench, 10# open-end wrench, 14# open-end wrench, sharp-nosed pliers

1. Remove the rear brake pump coter pin and pin ① with a pair of sharp-nosed pliers.
2. Remove the M10×25 bolt ② with a 14# open-end wrench.
3. Remove the rear brake switch spring ③.
4. Replace the longer rear brake switch spring (included in the accessories) ④.
5. Install the front right footrest to the front position and tighten the M10×25 bolt ②.
6. Install the rear brake pump extension push rod (included with the vehicle) ⑤ onto the rear brake pump push rod, connect the brake pedal to fit the rear brake pump coter pin and pin ①, adjust the brake pedal to the proper height, and tighten the rear brake pump push rod lock nut ⑥.

PKE operating instructions

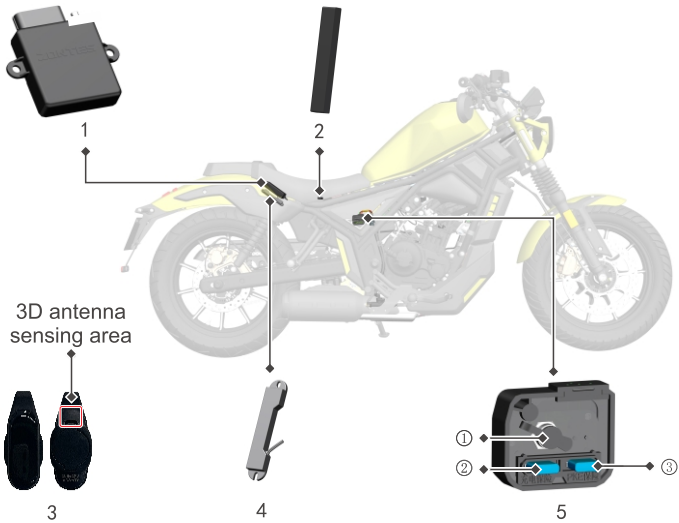

PKE (keyless entry system) instructions for use:

The PKE system consists of PKE main body (Figure 1), low-frequency transmitting antenna (Figure 2), key (Figure 3), powerless induction antenna (Figure 4) and PKE accessories (Figure 5), five parts.

PKE accessory (Figure 5) function description:

① battery charging DC interface ② charging insurance ③ PKE insurance

1. Use of inductive key

The vehicle is equipped with two inductive keys, one of which should be kept in a safe place for spare use. Both keys are labeled with a number that corresponds to the number of the PKE main body, and the PKE main body can automatically recognize the corresponding one near the vehicle without activation.

PKE operating instructions



·There are 2 LEDs, green and red, on the PKE key. If power of battery in the key is sufficient, when the PKE host is on, the green LED on the key flashes every 3 seconds. If power of the battery is low, red LED flashes. (The LED flashes once when the battery is just installed. This helps judges if the key is battery status).Due to the limited capacity of the key battery, the normal battery life is about 18 months.If the key is not sensitive or the sensor key indicator flashes red, please consider replacing the battery (there is a pry opening on the back cover of the sensor key, which can be replaced by prying it open, the battery is a 2032 button battery).

2.PKE working:

When the PKE is connected to the power supply for the first time (such as connecting to the battery power supply or plugging in the PKE fuse), when the key is not within the sensing range of the vehicle, the vehicle will beep 4 times, representing

1. PKE normal reset working signal
2. Start button pressed signal (similar to pressing the “” button). If the key is detected, the motorcycle will be on. If not, the motorcycle will enter non-electric inductive mode.
3. Long press start button, non-electric inductive mode on signal
4. Non-electricity inductive mode off signal.



·The non-electric induction detection is executed between the 3rd and the 4th beep. Detection period is 5 seconds.

3.Turn on the PKE:

Short press the “” button on right sub handle switch . Turning lights flash 2 times. Steering lock is unlocked automatically. Then a beep signal while the circuit is on.



·If the steering lock is not unlocked successfully, it may be that the handle locks the connected lock shaft, gently turns the handle to allow the lock shaft to move freely, or the battery may be too low to unlock, please check if the battery is normal.

PKE operating instructions



- If the battery power is normal, short press the “” button, the motorcycle cannot start up, but the main machine will give a "di" prompt, please try to use the induction key to start up without electricity (see the following instructions for specific operation). If the battery is normal and the host does not give a "di", please check whether the PKE fuse (the fuse position is as shown in FIG. 4) is normal. If the fuse is replaced, please be sure to replace the fuse of the same specification (15A).
- When the battery is dead, please try to turn it on after charging.



- Note: When the vehicle is working or moving, all buttons of the right auxiliary handle switch (Figure 6) are shielded and can only be used when the vehicle is stopped and the ignition is off.

4. Turn off the PKE:

After stopping and parking the motorcycle, put handlebar to the left, turn off the engine, long press the “” button on right handlebar, the turning signal will double flash twice, the steering lock will be locked automatically, then the buzzer "di" 1 sound to prompt, the electric circuit is unconnected.





- After turning off the motorcycle, please check if the steering lock is locked. If the steering lock is unlocked, please put the handlebar to the left, the motorcycle will be locked automatically.
- If the handlebar is not put to the left and turn off the motorcycle, it is forbidden to push the motorcycle or let the motorcycle slide, in case to put the handlebar to the left to lock the head lock, it is dangerous.
- When pushing the motorcycle or let the motorcycle slide from the hill, make sure the PKE is turned on (the steering lock is unlocked successfully)

PKE operating instructions

5. Non-electric induction start mode:

When the battery power of the induction key is low or there is no key battery, you can start the machine through the non-electric induction mode. The specific steps are as follows:

- (1) Select one of the following operations when the power is off:
 1. Press “ - 2. Press “ - 3. Repower the unit (e.g. connect the battery, plug in the main fuse, plug in the charging fuse and PKE fuse successively), and hear the third "tick".
- (2) Press the key induction area (picture 4) against the non-electric induction area (picture 3) within 5 seconds.

 ATTENTION

- You can also place the key induction area (Fig. 3) against the non-electric induction area (Fig. 4) first, and then proceed to step 1.
- The key is no longer detected after power-on without electric induction, please pay attention to power off when leaving the vehicle.

PKE Host buzzer sound

The PKE host buzzer prompts the user to detect an abnormal condition by a combination of long and short “Bi” other prompt sounds. The specific meanings are as follows:

“START” button stuck	One long and two short	The button is detected to be stuck after each power-on, and the alarm is once within 10 seconds (only once)
Fuel tank lock button stuck	One long and four short	After the button is stuck and then turned on, and the alarm will be activated once in 10 seconds. After the turn on and then stuck, and the alarm will be triggered once within 10 seconds.
Cushion lock button stuck	Two long	After the button is stuck and then turned on, and the alarm will be activated once in 10 seconds. After the turn on and then stuck, and the alarm will be triggered once within 10 seconds.

PKE operating instructions

High frequency reception abnormality	Two long and one short	When the TEST button is turned on, it detects that the PKE host has received a high frequency reception error, and the alarm is once (only once).
Loss of induction key pairing	Two long and three short	Induction key pairing lost alarm once every time it is turned on (only one alarm)
Induction key is low battery	Three long	Abnormal signal of sensor key battery is detected when starting with TEST key, and alarm is given once (only once)
Steering lock open abnormal	Five short	An unlocking in-position signal is detected every time the power is turned on, and the alarm is once (only once)
Steering lock is abnormal	Five short	The lock-in-place signal is detected abnormally every time the power is turned off, and the alarm is once (only once)
Lowfrequency transmitting antenna is abnormal	Three long and one short	The lock-in-place signal is detected abnormally every time the power is turned off, and the alarm is once (only once)
Induction key awayfrom detection area	Eight short	The lock-in-place signal is detected abnormally every time the power is turned off, and the alarm is once (only once)

Instrumentation

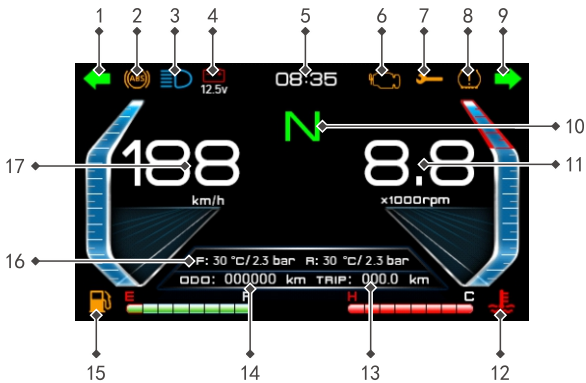

Short press the “” button of meter, then the meter will perform the process of self-test.



· Do not use high pressure water washing instrument directly.
 · Do not use dishcloth with organic solvent such as gasoline, kerosene, alcohol, brake fluid to wipe the instrument, Otherwise, the instrument may cause local cracks or discoloration due to exposure to organic solvents.

1. Left turn light

 When the turn signal switch to the left, the left turn signal light will be flashing.

2. ABS anti-lock braking system signal light

 ABS indicator: used to display the working condition of the ABS control system. When the key is turned to the "NO" position, the vehicle is powered on and the parking is stopped.

Normally the ABS indicator light will come on automatically. When the vehicle speed exceeds 5km/h, the ABS indicator light will automatically turn off. Otherwise, it means that the ABS control system has a fault barrier. Please contact our after-sales service point for inspection.

Instrumentation

3. Distance light lamp

 When using the high beam headlights, indicator light will be lighter.

4. Battery voltage prompt

 When the engine is off, if the detection voltage is less than 11.9V, the display symbol will alarm in the way of flashing this flashing frequency is 1Hz. When the detection voltage is greater than 12.1V, the alarm will be canceled automatically.

When the engine is on, if the detection voltage is less than 12.6V, the display symbol will alarm in the way of flashing this flashing frequency is 1Hz. When the detection voltage is greater than 12.8V, the alarm will be canceled automatically.

When the low voltage indicator of the battery flashes, it means the voltage of the vehicle is lower than the set value. If the indicator is continuously on for a long time, it means that it is an abnormal phenomenon. Please contact our company for after-sales inspection. After the inspection, If the battery is dead, charging the battery will make it back to normal. If the battery is damaged, the battery needs to be replaced.



· If the voltage is higher than 16V, you must stop using the vehicle immediately and contact after-sales service point of the company for inspection.

5. Clock

The clock display in the 24 hours system.



· If the battery is removed or battery lost electricity, it will be shown from "00:00" clock.

6. Fuel injection error signal light

 After the engine is successfully started, during normal running, the EFI fault light is off; if the EFI fault light is on at this time, it indicates that the EFI system is faulty.



· When the fuel injection system is showing error, it will break the fuel injection system when you still drive the motorcycle. Please contact the after-sales dealership shop to check the fuel injection system.

Instrumentation

7. Oil level warning light

 The first prompt is 1000km, and the second prompt is that the instrument mileage is 5000km. In the future, when driving every 5000km, the maintenance prompt light flashes, 200km in advance each time, and the power-on flashes for 5 seconds to prompt maintenance. After the maintenance is completed, short press SET to enter the main menu of the instrument to the vehicle information interface; long press the SET key to display whether to clear, and short-circuit SET to confirm the clearing.



Please properly deal with waste engine oil, do not prevent the environment. We suggest that you will put waste oil into a sealed container to a local recycling center. Don't put them into the dustbin or directly into the ground.

8. Tire pressure indicator light

 When the tire pressure and temperature are abnormal, it will flash an alarm and need maintenance and inspection.

9. Right turn signal light

 When press the right turn signal right to the right, it will be flashing.

10. Gear display

The motorcycle is using international gear, and there are six gear display which is 1,N,2,3,4,5,6 shown on the instrument.

11. Engine tachometer

Displays the engine speed, which means the number of revolutions of the engine shaft per minute.

12. Water temperature

 After the power is turned on, turn off the engine switch of the handle. After the EFI is powered on, the water temperature state is displayed. One grid indicates that the water temperature is lower than or equal to 60 °C, 61-70 °C shows two grids, and 71-80 °C shows three grids, 81- 90°C shows four grids, 91-100°C shows five grids, 101-110°C shows six grids, 111-120°C shows seven grids, and 121°C above shows eight grids. When the water temperature is greater than 111 °C, the water temperature indicator will start to alarm and the cooling system needs to be checked.



Please properly deal with waste engine oil, do not prevent the environment. We suggest that you will put waste oil into a sealed container to a local recycling center. Don't put them into the dustbin or directly into the ground.

Instrumentation

13. Tripmeter

There are two functions in the display area of the screen, which are the TRIP MODE and the ODO MOD. The TRIP MOD records accumulated mileage per drive, long press MOD key to clear zero, the maximum recorded value is 999.9.

14. ODO dometer

The ODO MOD records the driving mileage in total from the beginning to the present. The recorded information cannot be cleared, and the maximum recorded value is up to 999999.

15. Fuel level gauge

 The fuel level gauge shows the amount of fuel remaining in the fuel tank. The fuel level gauge shows 8 segments, indicating that the fuel tank is full. When the remaining fuel is low, the fuel indicator flashes, and fuel should be added as soon as possible.



· When the motorcycle is parked by using side stand, fuel gauge can't accurately show. Put the motorcycle into normal driving status, after we turn on the red power-on button, we don't need to start the engine, and we have to wait about half minute to let it accurately show; or shut down the red power-on button, turn it on again, the fuel level gage will demonstrate correct oil level information immediately.

16. Driving information

The record displays motorcycle information such as fuel consumption, average speed, cruising range, tire temperature and air pressure. The average fuel consumption is displayed when the motorcycle is stationary, and the instantaneous fuel consumption is displayed after the motorcycle is started.

17. Speedometer

Speedometer shows the speed is how many kilometers per hour (/miles).

Instrumentation

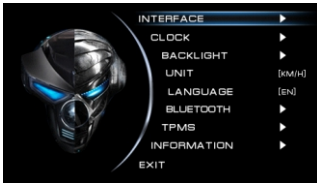

Figure 1



Figure 2



Figure 3



Figure 4

As shown in figure 1: Main menu

Menu operation: Short Press the SET button on the main interface to enter the main menu. Long Press the SET button at any time to return to the main interface, or the screen can automatically return to the main interface without any operation for 8 seconds. Short press the MOD button, then the cursor will moves downwards, short Press SET button to enter the secondary menu or set options.

① Interface style

The four interface styles are leisure, racing, street, and simplicity, respectively. Short press MOD button to move the cursor to select the option, short press SET button to confirm the option, then it will automatically return to the previous level.

② Clock Setting

The clocks and minutes are set individually in digital bits. When entering the clock setting, press digit setting from left to right, short press MODE key to increase digits, loop around, short press SET key to determine the current digit key, and then switch to the lower digit setting. After the last digit setting is completed, short press SET key to determine, and the interface will automatically return to the upper menu.

③ Instrument backlight brightness adjustment (figure 3)

Press the MOD key to change the backlight brightness gear (auto, 1, 2, 3, 4, 5) and press the SET key to confirm the selection.

Instrumentation

Automatic transmission: the old instrument has the darkest backlight when the headlight switch is turned on, and the backlight is the brightest when the headlight switch is turned off, automatically switching between two brightness levels; the new instrument automatically adjusts the backlight brightness and darkness according to changes in the light sensing environment.

④ Unit setting

Short press the SET button to alternately switch the unit display, and the speed unit can be switched between mph and km/h. Correspondingly, the mileage unit can be switched between mile and km.

⑤ Language setting

Short press the SET button to switch language between Simplified Chinese and English.

⑥ Bluetooth connection

When Bluetooth function is enabled, the OTA upgrade meter program can be connected after Bluetooth

⑦ Malfunction information (figure 4)

Current fault code, historical fault code, software version number.

Tire pressure monitoring function (figure 5)

The tire temperature and pressure data can be viewed on the main interface by short-pressing MOD to switch driving information or entering the "Main Menu-Tire Pressure Settings".

There are three pressure units: Psi, Kpa and Bar. Short press the SET button to switch, short press MOD to confirm and jump to the next item.

Tire pressure function description:

The tire pressure monitoring function is enabled, the tire pressure data will be monitored at all times, and the tire pressure prompt lamp will be on in case of abnormality.

The tire pressure monitoring function is off and does not prompt for tire pressure related data.

1. Tire pressure and temperature alarm

When the instrument receives that the tire pressure temperature information from the sensor exceeds the limit value, the instrument interface displays the corresponding tire pressure temperature alarm text, and the tire pressure indicator flashes (1 Hz).

2. Low voltage alarm

When the tire pressure sensor detects that the battery voltage value is lower than 2.6V, the interface shows that the sensor battery is low, the alarm will not disappear until the new sensor is re-matched, and the tire pressure indicator flashes (1Hz).

Instrumentation

3. Air leakage alarm

When the sensor detects the change of tire pressure (decompression), it will prompt a leak alarm and the tire pressure indicator will flash (1 Hz).

4. Unlearned alarm

When the meter does not match the sensor and the tire pressure setting interface displays "Not Learned", the main interface displays "Not Learned Alarm" and the tire pressure indicator flashes (1 Hz).

5. Sensor loss alarm

When the signal from the sensor is not received, the meter shows that the sensor is missing and the tire pressure indicator flashes (1 Hz).

Remove alarm: The alarm disappears after receiving valid data.

6. Sensor failure alarm

When the meter receives the sensor chip fault information, the interface displays the sensor fault alarm and the tire pressure indicator flashes (1 Hz). At this time, the sensor needs to be replaced, otherwise the tire pressure information cannot be displayed normally.

7. System failure alarm

When the chip that receives the signal inside the instrument fails, the instrument interface displays a system failure alarm and the tire pressure indicator flashes. At this time, the instrument needs to be replaced, otherwise the tire pressure information cannot be displayed normally.

8. Learning matching function

① First adjust the motorcycle meter to the learning mode, that is: power on the meter → enter the menu → tire pressure setting interface → operate the instrument button to set the front (rear) wheel to "learning..." and wait for the tire pressure sensor to learn information.

② Continue to inflate or deflate the corresponding front wheel or rear wheel until "Success" is displayed.

③ When the meter receives the matching signal from the tire pressure sensor, after the match is successful, the text "Learning..." on the tire pressure setting interface will be displayed as "success". At this time, the meter can receive the tire pressure temperature information of the sensor. If the learning is unsuccessful, you need to repeat the above operation and increase the time of inflation and deflation.

Instructions for Fuel, Oil, Coolant and Gear Oil

Fuel

The pure 95# or more unleaded gasoline must be used. The pure 92# unleaded gasoline can only be used in a short time in case of emergency, otherwise the engine lifetime will be shortened.

If there are tapping based on experience, you can use level higher gasoline or use other sellers of gasoline. Because there are differences between different brands.

Engine oil

Use high quality SN or above level four-stroke engine oil can prolong engine life. Please choose API SN level or higher level of "four stroke motorcycle engine oil".

WARNING

· The unleaded gasoline, poor quality fuel oil and engine oil can damage the system components, and it will shorten the service life of catalyist in spark plugs and muffler. Unclean fuel oil can block the oil-way, resulting in abnormal engine working, don't use that kind of oil.

ATTENTION

· Please properly deal with waste engine oil, do not prevent the environment. We suggest that you will put waste oil into a sealed container to a local recycling center. Don't put them into the dustbin or directly into the ground.

Engine coolant/antifreeze

The coolant/antifreeze we use is suitable for the aluminum radiator. The coolant/antifreeze is a mixture of coolant/antifreeze concentrate and water. If the outdoor temperature is higher than the freeing point of the coolant/antifreeze, it can be used. When you add or cool the coolant/antifreeze, please use alcohol as the foundation.

WARNING

· The coolant/antifreeze which splash out is possibly do harm to the surface of the motorcycle. Please be careful when you refill the coolant/antifreeze. If it splash out, please clean it immediately.

Instructions for Fuel, Oil, Coolant and Gear Oil



· It is bad for health if you swallow or absorb the coolant/antifreeze. Therefore, when you use it, please don't eat and drink. After every work, please clean your hands, face or any skin parts demonstrated. If you swallow it mistakenly, please go to the hospital immediately. If you absorb it mistakenly, please breathe more fresh air in the environmental in where there is full of fresh air. If the coolant/antifreeze runs into your eyes mistakenly, please watch your eyes with large amount of water at once. Also, keep the liquid away from kids and pets.

Distill water for coolant/antifreeze

If you need to add water, please use the distill water. If you use other kinds of water, it would probably do harm to the cooling system.

Coolant/antifreeze

Coolant/antifreeze can prevent routing and lubricate the coolant/antifreeze pump. Therefore, if the outdoor temperature is higher than the freeing point of the coolant/antifreeze, it can be used.



· Please refer to the instruction of coolant/antifreeze product when you use it.

· When adding coolant/antifreeze, ensure that the engine is cold. Do not open the tank cover of the hot engine, which may cause danger!

After the tank is filled with coolant/antifreeze, do not close the tank cover and start the engine idling (Appropriate fueling) for a period of time. At this time, air is discharged from the water inlet. After the air is discharged, add more coolant/antifreeze. Once, until there is no air discharge from the water inlet, it can be considered that the water tank has been filled up before the water tank cover can be closed.

· The sub tank coolant/antifreeze is added between “L” and “H”.

The volume of coolant/antifreeze

Coolant/antifreeze volume (total volume): 860ml.(Including auxiliary water tank about 200ml)

Instructions for Fuel, Oil, Coolant and Gear Oil



• Please choose the suitable coolant/antifreeze according to the driving air environment.

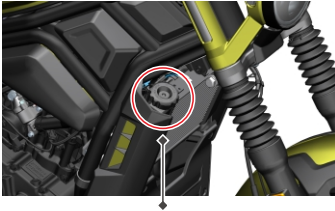

Radiator cap

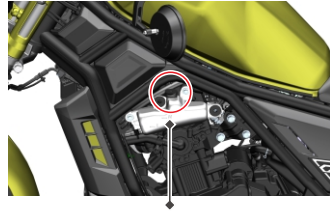

The cover of the auxiliary water tank

At all times, the coolant (antifreeze) level position in the sub-tank should be maintained between the H and L lines. If the coolant (antifreeze) level is below the L line, follow the steps below to add coolant (antifreeze); it is recommended that the coolant (antifreeze) be replaced every 3 years or 30,000 kilometers.

1. Park the motorcycle with the side stand.
2. Unpack the left toolbox.
3. Note that the oval opening of the rubber cap faces outward for easy removal.



• In order to correctly check the surface level of the coolant/antifreeze, we should put the motorcycle into the cooling engine condition.

• If the main water tank is empty, please check and repair the cooling system immediately. After you finish fixing the cooling system, add some coolant/antifreeze inside.

Instructions for Fuel, Oil, Coolant and Gear Oil



· It is bad for health if you swallow or absorb the coolant/antifreeze. Therefore, when you use it, please don't eat and drink. After every work, please clean your hands, face or any skin parts demonstrated. If you swallow it mistakenly, please go to the hospital immediately. If you absorb it mistakenly, please breathe more fresh air in the environmental in where there is full of fresh air. If the coolant/antifreeze runs into your eyes mistakenly, please wash your eyes with large amount of water at once. Also, keep the liquid away from kids and pets.

Change the coolant/antifreeze

It is suggest that you change the coolant/antifreeze completely every 3 years or 30000 kilometers.

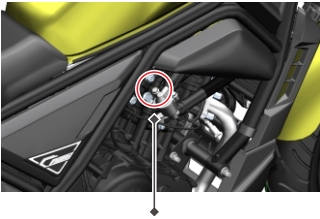

bleed bolt



And the cover of the
main water tank.

Inspection and Maintenance

First Inspection

The initial 1000 kilometers of maintenance is one of the most important work. During this period, all engine parts should have good running-in. In the case, maintenance and repair should put all the parts to readjust, tighten all fasteners, replace parts abrasive dust pollution of the oil. Repair, about 1000 kilometers seriously for the first time, will guarantee your motorcycle to play the best performance and prolong its service life.

WARNING

•According to the instruction for use in the inspection and maintenance of an execution section for 1000 kilometers Maintenance and repair. Please pay special attention to the danger and warning content of this section.

Pre-driving inspection

If it's not well check before driving the motorcycle, and there is no proper maintenance, it will increases the risk of accidents and the risk of motorcycle damage. Always check the motorcycle during daily usage, make sure it is safe to run. Refer to the instruction manual inspection and maintenance of the chapters.

If the motorcycle uses inappropriate tires, or operating motorcycle not correctly, or tire pressure is not correct, you will lose control of the motorcycle. have to use in this instruction manual provisions size and specifications of the tires. Always in accordance with the requirements of the inspection and maintenance section to keep proper tire pressure.

Keep proper wheel pressure

Inspection content	Key points for inspection
Steering system	Active steering, no block for moving, no working loose.
Accelerator	Correct accelerator inhaul space, smoothoperation; smooth holding for accelerator
Brake	Normal operation on braking controller and braking pedal; braking liquid above The LOWER line of the braking liquid cylinder; no feeling of inactive braking; no brake drag and brake liquid leak; braking plate wear within range

Inspection and Maintenance

Shock absorber	Smooth and active controlling
Fuel oil	Enough planning distance oil level
Engine lubricant	Is the amount of oil sufficient
Lamplight	Normal working for all kinds of light in the motorcycle
Indicator light	Distance light, turn signal right working normally
Horn	Working normally
Brake switcht	Working normally
Shut down switch	Working normally

The importance of these tests can never be neglected. Complete all of the inspection before driving and necessary repairs.



WARNING

· **When you do the inspection, engine running status is more dangerous for you to inspect. If your hand or clothes are moving parts involved in the motorcycle, it will cause serious damage to you. In addition to check the engine flame out switch and power to run the engine, shut down the engine when you perform other checks.**

Maintenance schedule

The table below is the inspection for each regular maintenance should be done, the interval period should be used in months or mileage depending on which one reached first. Each check should be carried out in accordance with the project in the table below.

If your motorcycle has been used in harsh conditions, namely the continuous driving in large throttle or worked in wind sand, it should have special maintenance to keep the reliability of the motorcycle after driving. The repair units can provide you with further advice. Especially, shock absorber and wheel steering system are key parts, and they require specialized technology and careful maintenance. To be safe, we recommend the work best done by a qualified repair units.

Inspection and Maintenance



- Initial 1000km maintenance is the must-follow project, it can make your motorcycle always reliable and have superior performance.
- When the engine is working and just stalling, the temperature of the muffler is high, please do not touch to prevent burns.
- Improper maintenance or problems after maintenance will cause an accident. To keep your motorcycle in good condition, it request the company qualified maintenance unit complete with mark project. Refer to this section, if you have any mechanical maintenance experience, you can maintain the unmarked items; if you are not sure how to deal with the work, let your repair units to complete the maintenance.



- Pay attention to the maintenance regularly to see whether full compliance with the prompt or not carefully. The initial 1000km maintenance, shall be carried out according to the method described in this section. "Dangerous "and "Warned" in this section should pay special attention to. Replacing the wrong parts can lead to motorcycle accelerated wear and tear, and shorten the service life of the motorcycle. When the motorcycle needs to replace parts, you can only use pure part of the company.
- Waste in the maintenance process, such as cleaning agents and waste engine oil should be properly handled so as not to damage to the environment.

Inspection and Maintenance

Scheduled Maintenance Sheet

- I: Check (clean, lubricate, adjust or replace if necessary)
 R: Replace
T: Tighten

Cycle Inspection Item	Check before driving	First1000	Each5000	Each10000	Regular replacement
		frist 3	Each 15	Each 30	
Air filter (filter)			I	R	
Muffler suspension hollow buffer gluer			I		
Muffler bolt, nut		T		T	
Engine oil	I	R			★ Note 1
Engine oil filter		I		I	
Ignition plug				I	
Clutch controller free stroke		I	I		
Throttle body		I		I	
Throttle digging line gap		I	I		
Idling		I	I		
Radiator rubber hose			I		
Brake		I	I		
Brake hose			I		Replace every 4 years
Brake fluid			I		Replace every 2 years
Tires			I		
Fuel pipe			I		
Transmission chain			I		

Inspection and Maintenance

Scheduled Maintenance Sheet

- I : Check (clean, lubricate, adjust or replace if necessary)
 R : Replace
T : Tighten

Cycle Inspection Item	Check before driving	First1000	Each5000	Each10000	Regular replacement
		frist 3	Each 15	Each 30	
Bolts and nuts in steering gear		T	T		
Front shock absorption				I	Replace every 3 years or 30,000 km
Rear shock absorption				I	
Coolant			I		Change once every 3 years or 30000km
Anti-wear block of rear fork lift		T		T	
Fuel Evaporative Pollutant Control System				I	
Internal moving mechanism of faucet lockr					Check, clean and lubricate
Steering Bearings inSteering Mechanisms					Check, clean, lubricate every 5,000 kilometers
Eccentric chain regulator NK50-25 needle roller bearing				I	Check, clean and lubricate every 6000km
Body and the engine installation of bolts and nuts		T	T		
Check valve clearance (cold) In 0.10-0.14mm / Out 0.18-0.22mm				I	

Inspection and Maintenance

★ Note1: First maintenance for the first 1000 kilometers or 3 months (whichever comes first), second maintenance for the actual mileage of the instrument when the actual mileage reaches 4000 kilometers, and every 4000 kilometers or 15 months thereafter (whichever comes first) Perform a regular maintenance.

Inspection and Maintenance

Fuel Tank Removal

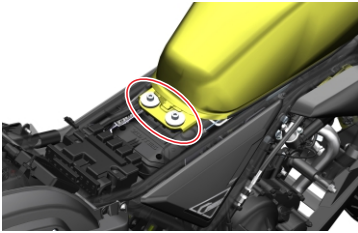

Figure 1

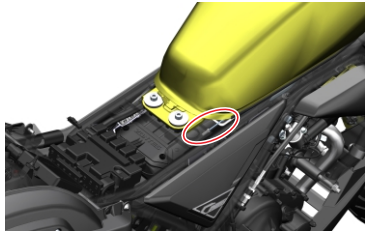

Figure 2

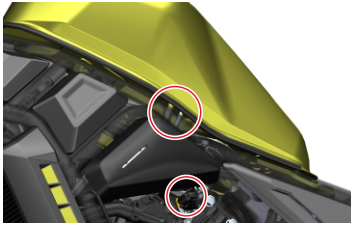

Figure 3

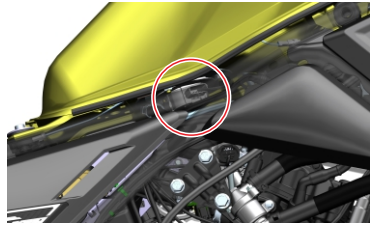

Figure 4

The steps to remove the fuel tank are:

1. unplug the tail light connector (the connector is located on the right side of the bottom of the seat) and remove the seat; use a 6# hex to remove the two M8 bolts at the end of the fuel tank (Figure 1).
2. Remove the connector between the electronic fuel tank lock protection plate and the cable (Figure 2).
3. Slightly lift up the rear part of the fuel tank and remove the fuel adsorption pipe and water leakage pipe on the left side of the tank (Figure 3); remove the fuel pump connector on the right side of the tank (Figure 4).
4. Hold the fuel tank with both hands and move it backward to remove the entire tank from the vehicle and place it in a safe area.



- The fuel tank is correctly positioned.
- The tubes are connected properly.
- When installing the fuel pipe, prevent foreign objects from entering the fuel pipe.
- Before installing the fuel tank, check the fuel vapor adsorption pipe to make sure it is not bent or kinked.

Inspection and Maintenance

Fuel tank inspection and repair

The fuel tank is located in front of the seat, when opening the outer fuel tank cover, make sure that the engine off switch is off and the whole vehicle must be energized to open the fuel tank cover. First, snap up the fuel tank cover ① to open the fuel tank cover ②.

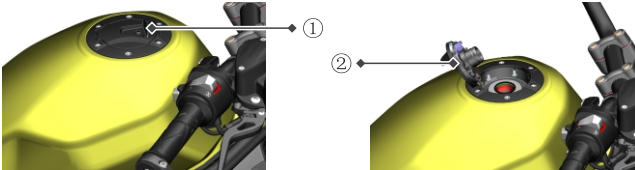

- Avoid overfilling the fuel tank so that the overflowed fuel will not flow to the hot engine. The fuel level should not exceed the bottom of the fuel tank opening, otherwise, the fuel will overflow when it expands with heat and will damage the motorcycle parts.
- Turn off the engine when refueling, make sure the engine off switch is off, and do not approach a smoldering fire.
- Do not overreach the fuel gun into the fuel tank to avoid damaging the fuel sensor.
- Take some precautions when adding fuel, otherwise, it may cause fire or inhalation of fuel vapors. Be in a ventilated area when refueling. Make sure the engine is turned off, avoid fuel spills, prohibit open flames, and make sure there are no heat or ignition sources around. Avoid inhaling fuel vapors. Keep children and pets away when refueling.



- Do not use high-pressure water to rinse the fuel tank cap when washing the vehicle to avoid water entering the fuel tank.
- If the fuel tank cap is stuck and cannot be opened, press down hard on the fuel tank cap and try to open it after the whole vehicle is shut down and restarted.

Inspection and Maintenance

Tool kit

The tool kit is placed in the toolbox on the right side of the vehicle, directly remove the toolbox decorative cover to see the tool kit, the location is shown in the figure.

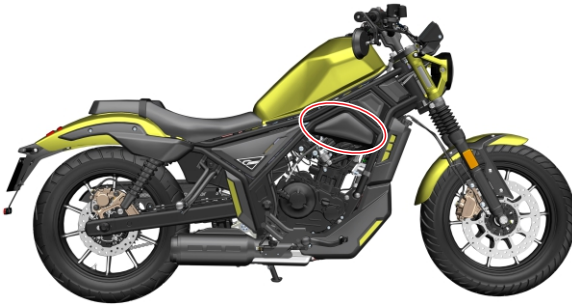

Inspection and Maintenance

Lubricating point

For safe driving, you have to keep good lubrication which can maintain the smooth operation, and prolong service life. After using in harsh conditions, after the vehicle is wet by the rain, or after washing the vehicle, it should **belubricated**. Lubrication points are as follows:

D:Chain oil G:Grease

- ① Clutch handle shaft
- ② Left footrest shaft
- ③ Side parking stand shaft and spring hook
- ④ Drive chain

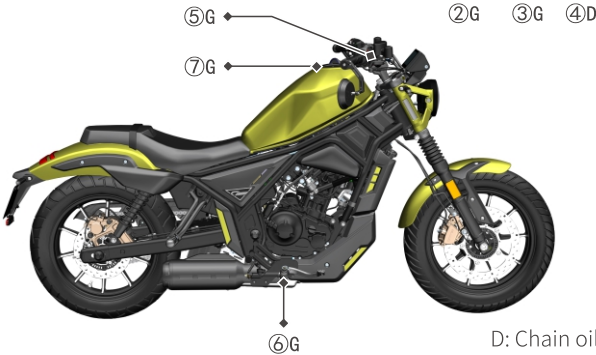

- D: Chain oil G: Grease
- ⑤ Brake handle shaft
 - ⑥ Right footrest shaft
 - ⑦ Fuel tank lock



•Lubrication might damage the switch. Don' T use grease or oil lubricate the switch.

Battery



Gel battery

Removing the battery

The battery is located under the driver's seat, please connect the positive and negative terminals and install the battery cover for the first time. Remove the battery in the following order:

- Turn off the motorcycle's power switch.
- Remove the seat and battery cover.
- Remove the negative terminal (-) by removing the black protective cap, and the positive terminal (+) by removing the red protective cap.

·When reinstalling the battery after removing the battery, you need to pay attention to straighten out the surrounding wiring harness, especially the position of the positive pole of the battery and other red, The wires need to avoid touching metal such as the frame and the battery box bracket, and the battery needs to be completely inserted into the battery box and the battery bandage must be tied (installed small cover) to ensure that the positive position of the battery is within the protection range of the positive protective plate.



·When reinstalling the battery, starting or when the whole vehicle has power failure, battery dormancy restarting, abnormal idle speed, plug and unplug fuse and other similar situations, please pay attention to reset individual hardware of the electronic injection. Steps: Turn on the electric door lock switch and the engine flameout switch, start the engine with the clutch of neutral gear. Turn off the engine flameout switch after 10 seconds and turn on the engine flameout switch after 10 seconds. Repeat 2 more times.

Battery

Replace the battery, please note the following:

When you replace battery, you shall confirm the battery type and verify the models are consistent with the original battery. the specification of the battery in motorcycle design is considered as the relative match. if switch to a different type of battery, it could affect the performance and life of the motorcycle, and is likely to trigger circuit fault.

· If you don't drive your motorcycle for a long time, please remove the battery and charge it per month.

· Battery should be checked regularly, if the voltage is lower than 12V, we suggest for battery charging.

Battery charging will shorten the life of the battery. Don't let the battery over charge.

· Please charge the battery when you use the professional lithium battery. The charging voltage should not be over 15V.

· Please properly deal with waste battery and waste electrolyte, don't damage to the environment.

· We suggest that you will recycle waste battery and waste electrolyte to a local recycling center. Don't discard it in the dustbin or discarded directly on the ground.

If the battery voltage is greater than 12.3V, the meter restarts with a black screen when igniting, you need to short-circuit the start relay to see if the same situation exists, such as

If the situation is the same, do not ignite for a long time (and each ignition time needs <3S) or stop the ignition, you need to go to the nearest dealer to check

· Whether the vehicle starting mechanism is normal, otherwise there may be a risk of burning the battery.



ATTENTION

· Please purchase and use our special charger to ensure the extension of the service life of the battery. There are lead-acid battery chargers for sale in Zontes shop. Users who need them can go to Zontes shop to purchase the corresponding chargers according to the batteries equipped with the model.

· It is not allow to use the unqualified charger to charge the original battery.



WARNING

Instructions for using the battery

1.The start of the new storage battery

Storage battery installation

a. Before installing the battery, check the appearance of the battery. The outer casing should be free of scars or cracks, the battery cover should be well sealed, and there should be no leakage, and the terminals should be free of skewing, deformation, etc.

b. After tightening bolts on the bolt, nut, terminal butter or vaseline, to avoid poor contact rust.

2.Use and maintenance

2.1 Each electric start-up time not more than 5 seconds, if you continue trying a few times and it can't start, you should check the oil supply system and starting, ignition system.

2.2 The following conditions will cause the gel battery to be over-discharged or under-charged to shorten the battery life.

a. Frequent electric start.

b. Short riding time and short driving distance.

c. No ignition after long-time startup.

d. Install additional electrical devices, such as high-power spotlights, audio, GPS and other electrical equipment.

2.3 If the starter motor is weak, the light is dim, the horn sounds hoarse, and the ignition appears black screen restarts and other abnormal phenomena, the battery should be recharged immediately.

2.4 When the motorcycle is not in use for a long time, the battery should be removed and stored separately, or the battery cable should be disconnected. Please recharge the gel battery before stopping the motorcycle, and recharge it once a month.

2.5 Charging Precautions:

a. When charging, please use the special charger provided by our company for charging. You can use the motorcycle's own charging port or remove the battery to charge separately.

b. When charging, try to refer to the following charging instructions to avoid high-voltage and high-current charging to extend the battery life.

c. Do not overcharge the battery. Overcharging will cause the battery to leak, bulge or even burst, which will cause varying degrees of danger.

Instructions for using the battery

3. Attention

3.1 This battery is a maintenance free gel battery. It is strictly forbidden to open or modify the battery without permission. Do not add electrolyte or water without permission. It is strictly prohibited to put it in a place with high temperature and open flame.

3.2 When using and charging gel batteries, it is strictly forbidden to approach an open flame, and avoid short-circuiting of the positive and negative electrodes and loosening of the positive and negative terminals to prevent the battery from exploding.

3.3 During use or charging, the battery has a peculiar smell, severe heat, discoloration, or deformation. Please remove the battery from the car body or the charger and stop it immediately

3.4 The gel battery is standard for motorcycles, please do not use it for other purposes than the start of the motorcycle..

3.5 The installation of external devices such as security devices, GPS, spotlights, etc. will have a certain impact on the battery and the circuit of the motorcycle. Adding qualified brand products must be selected and connected to the reserved interface of our company. Do not change the wiring privately, otherwise it will cause The circuit system of our vehicle may work abnormally and cause the gel battery to be over-discharged.

3.6 Do not drop the battery. The electrolyte contains sulfuric acid. Avoid splashing on the skin, eyes and clothes. Once in contact, please wash with plenty of water and send to hospital for treatment.

Fuel consumption

"Consumption" of powered by fuel motorcycle, refers to the vehicle with the fuel consumption at least one driving speed constant speed. Each vehicle will be equipped with "vehicle parts list" and it is also available for you to get the electronic version from our official website.

Charger instructions

When the vehicle has not been driven for a long time or for other reasons the battery feeds and cannot be started, please follow the steps below to recharge the battery:

1. Remove the lower cover of the Figure 1 electrical parts box.
2. Plug the DC output cable end of the charger into the PKE charging port;
3. Plug the charger input AC seat directly into the household 110-220V power supply, make sure the vehicle is off during the charging process, and unplug the charger when the charging is completed.”

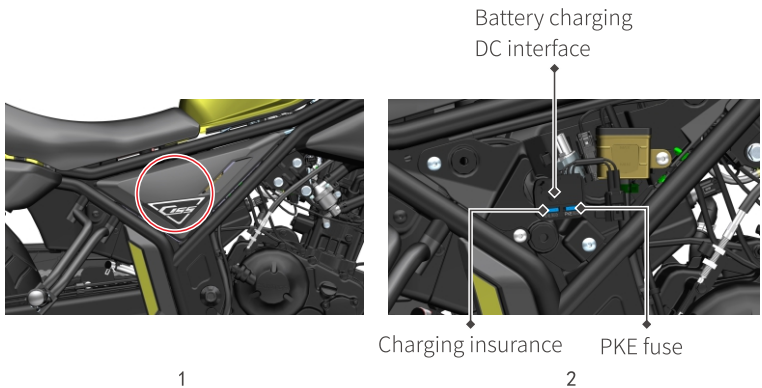

LED indicator

Battery charger	Red light	Charging mode
	Green light	Trickle mode charging



Battery charger



Lithium battery needs to be charged with lithium battery charger, please buy our special charger, the chargers are available in ZONTES shop, it is forbidden to use other unqualified chargers to charge the battery

Air filter cartridge

The air filter is located under the seat. If the air filter is clogged with dust, it will increase intake resistance, reduce power output and increase fuel consumption. Check and clean the air filter as follows.



WARNING

- If under the condition of dusty drive, you should increase the frequency of clean or replace filter.
- It is dangerous to run the engine without air filter. If there is no air filter inside the filter block, engine flame from the engine will jet to air filter inlet chamber.
- Dirt will enter inside of the engine, to cause harm to the engine. If there is no air filter cartridge, do not run the engine.

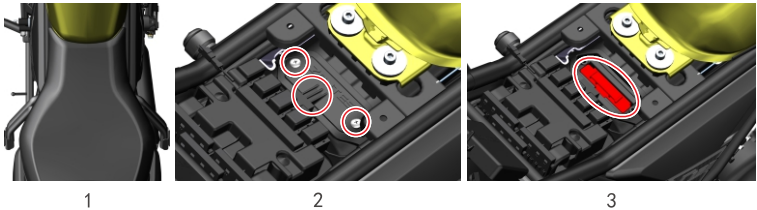

Maintain/replace the filter element:

1. Open and remove the entire seat by pressing the seat lock switch on the handlebar control system as shown in Figure 1.
2. Remove the two screws as shown in Figure 2, then remove the air filter rear housing cover and take off the dump switch hanging from the air filter rear housing cover.
3. Extract the filter element as shown in Figure 3 (Note: Please watch the video on the official website for detailed methods).
4. Observe the extracted filter element and blow off contaminants with a high-pressure air gun from the clean side. Replace the cartridge if it is heavily contaminated or damaged.
5. Install and restore the vehicle in the reverse order as described above.



ATTENTION

- If the air cleaner filter installation position is not correct, the dust will bypass the filter into the engine which can damage the engine. Make sure the filter installed in the correct position. In addition, when you flush the motorcycle, don't let the water into inside the air filter; if there is water into the air filter, you can pull the release the product oil pipeline, and make sure there was no swelling in the empty filter before using the motorcycle.

Air filter cartridge

Oil Pipe

1. As shown in Fig. 4, the oil pipe is located on top of the rear flat fork.
2. As shown in Fig. 5, put a piece of paper or a rag on the rear fork under the oil pipe, and then remove the clamp and pipe plug with a pair of sharp-nosed pliers to drain the waste oil.

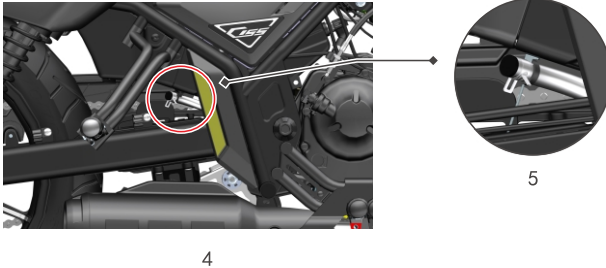

Spark plugs

Removing the spark plug

Follow the steps below:

1. Pull out the spark plug high voltage wire.
2. Remove the spark plug with a spark plug wrench.

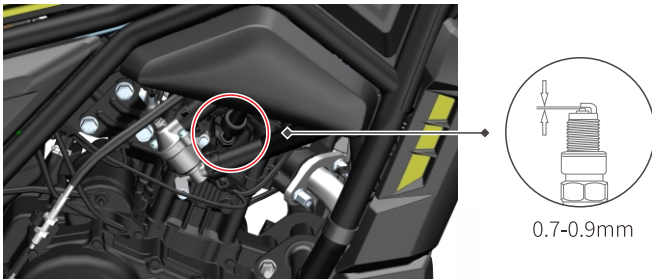

Disassembly the spark plug

Follow the steps below:

1. Disassembly the spark plug cap ,be careful not to use strong force, or you may break the spark plug.
2. To remove the spark plug with the spark plug wrench.
3. Check the spark plug.

Spark plugs

Checking the spark plugs

According to the maintenance schedule, the spark plug should be removed for inspection regularly. The condition of the spark plug can indicate the condition of the engine. The ceramic insulator around the middle electrode of the spark plug should be light brown (the ideal color when the motorcycle is running normally). If the spark plug has a significantly different color, it may be caused by poor engine operation.

If the spark plug electrode is corroded, excessive carbon deposits or other deposits, it should be replaced as soon as possible.

Installing the spark plug

Before installing the spark plug, use a feeler gauge to measure the spark plug gap. If necessary, adjust the gap to the specified value.

Clean the surface and contact surface of the spark plug gasket, and wipe off the dirt on the spark plug thread.

If there is a lot of carbon deposits, use a hard wire or steel needle to remove the carbon deposits attached to the spark plug.

Install spark plug

Torque: 14N.m

NGK	Annotation
CPR8EA-9	Standard spark plug
CR9E&CR9EI	Use the spark plug if the ambient temperature is too high and the spark plug is overheating.



WARNING

- The incorrect installation of the spark plug will damage the engine. If the torque of the spark plug is too large, it will also do harm to the engine. If there is no torque wrench when installing or replacing a new spark plug, screw it until there is resistance and then tighten it for 3/8 turn(135°). If used the old spark plug, screw the spark plug until there is resistance and then tighten 1/12 turn(30°), However, the spark plug should be screwd to the required torque as faras possible.
- The unclean material will go through the spark plug and go into the engine to do harm to it. Therefore, when we dismantle the spark plug, we have to use something to cover the installation hole of spark plug.
- It is forbidden to use spark plugs below LDK8RTAIP.

Engine oil

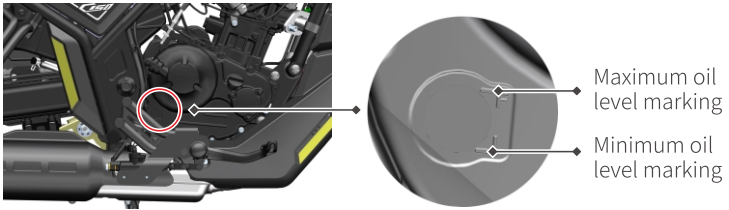

Whether the engine can be durable, it is very important to select the high quality oil and regular replacement of new oil. Check the oil level and oil change on a regular basis is two important tasks of maintenance project.

Checking the oil level

Check the oil level, according to the following steps to check oil level.

1. Park the motorcycle on a level surface and keep it upright.
2. Start the engine and run it at idle speed for 3-5 minutes.
3. Turn off the engine and wait 3-5 minutes.
4. Keep the vehicle upright and observe the oil inspection window. The oil level should be between the minimum and maximum oil level markings.



WARNING

· When the engine oil is too much or too little, running the engine can damage the engine. Stop the motorcycle on the flat ground and check the engine oil level gauge. The oil level must be between the lowest and the highest lines. When checking the oil level, make sure that the motorcycle is standing upright and slightly incline to either side may cause the inspection error.

Changing the oil

At each maintenance cycle, we should replace the engine oil. Oil change should be performed under the condition of the engine, so the old engine oil can discharge more thoroughly. Steps are as follows:

It is strictly forbidden to start or run the engine during the process of draining the oil. Before starting the engine, it must be ensured that there is enough oil in the engine.

1. Park the motorcycle on a flat surface with the side frame.
2. Unscrew the oil filler plug counterclockwise.
3. Place an oil drain pan under the engine oil drain bolt.
4. Remove the oil drain bolt with a tool and drain the old oil.

Engine oil



· Please replace the oil in the franchised dealer or repair shop. Unauthorized replacement is not allowed. Please consult the professional staff to ensure correct disassembly when the lower fairing cover is removed. Please dispose the disused engine oil properly and don't pollute the environment. We recommend that you put the disused oil into a sealed container and send it to the local recycling center. Don't put it in the dustbin or pour it directly onto the ground.

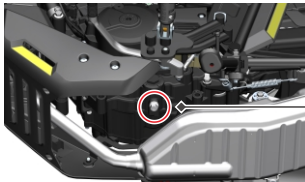

Engine oil drain bolt

5. Reinstall the oil drain bolt and its washer (make sure that the bolt threads are free of impurities and substances). Tighten the oil drain bolt with a professional tool. (Tightening torque $25 \pm 3\text{N}\cdot\text{m}$)
6. Add 1000 ml (1050 ml if the oil filter has been replaced) of oil (SN5W-40/1L) or new API SN motorcycle 4-stroke engine oil with viscosity SAE5W-40/10W-40/10W-50 from the engine oil filler hole. Then tighten the oil filler hole plug.



· If you doesn't use the prescriptive engine oil, it might damage the engine.

7. With different speeds launch machine for 3 minutes. When engine is running, check leakage situation with dismantling parts.
8. Operate the engine at idle speed for 5 minutes, and then turn off the engine for 3 minutes, check oil level through oil foot calibration. If the oil level is lower than the oil inspection port minimum scale line, you should add new oil to the highest scale line. Once again, check for leaks.



· When the engine is running, it is forbidden to open the oil filler plug to prevent the high temperature oil from splashing and hurting people.

Engine oil

Oil filter

1. Place the oil unloading tray under the right crankcase cover.
2. Remove 3 cap nuts on the oil filter cover with the special tool. Loosen the oil filter cover by rotating softly from left and right, and disassemble the oil filter cover. It is strictly forbidden to pick up the oil filter cover with a hard object, otherwise it will lead to oil seepage.
3. Disassemble the oil filter cover, and disassemble the old oil filter, the seal ring of oil filter will be stuck to the old oil filter. If don't replace the seal ring, please remove it and use again, but must not forget this seal ring.
4. Wipe off residual oil and impurities with a clean paper towel, check and install the filter spring and replace a new oil filter.



· It is very important to install the oil fine filter correctly, please use the original oil fine filter, please do not install the oil fine filter in reverse, spring and fine filter

· Do not forget to install the sealing ring. Be sure to double check that the use of a non-original oil fine filter or incorrect installation may result in contamination or missing oil cause serious damage to the engine.

Oil filter

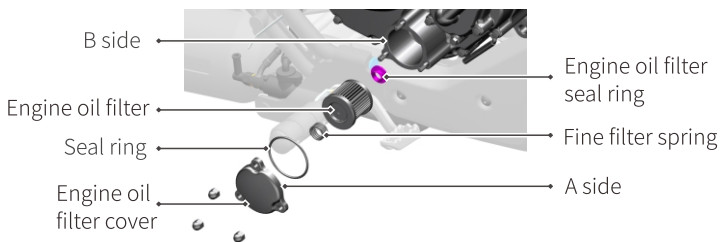

5. Before re-installing the oil filter cover: If necessary please replace the oil filter seal ring and O-ring on the oil filter cover, align the filter cover with the screw hole and press it in parallel with the mounting hole, Hold the fine filter cover by hand and pre-tighten the 3 cap nuts ,the end face (A side) of the filter cover is attached to the end face (B side) of the mounting hole. Pre-tightening 3 nuts to make sure that the filter cover can not bounce and then tighten the three cap nuts evenly. The standard torque is $10 \pm 1.5\text{N.m}$.



· Before installing the fine filter cover, please carefully check whether the O-ring on the oil fine filter cover is damaged. When installing the fine filter cover, the O-ring, the phenomenon of trimming should not occur. If there is damage or trimming, please ask the dealer to replace it in time, otherwise it will cause oil leakage.

· Be sure to install the fine filter cover according to the correct steps, otherwise it will cause oil leakage.

Clutch cable clearance

Clutch cable clearance

Measuring the clutch controller end free stroke, it should be between 10 ~ 15mm. If free stroke is not correct, accord with the following method to adjust.

Micro adjustment

1. Loose clutch digging line nut ①.
2. Rotate clutch digging line adjuster ② to get proper free stroke.
3. Screw down the clutch digging line nut ①.

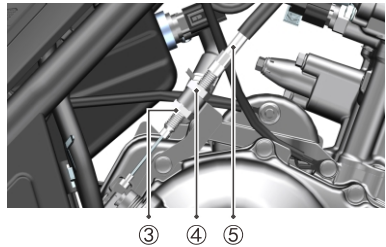
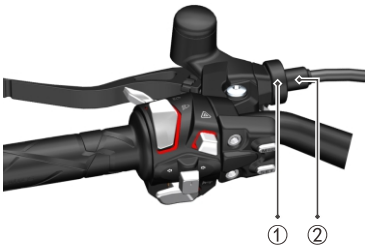
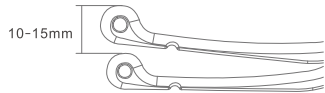

Large adjustment

1. Loose clutch digging line nut ③④.
2. Rotate clutch digging line adjuster ⑤ to get proper free stroke.
3. Screw down the clutch digging line nut ③④.



WARNING

- If the clutch controller free stroke is too large, it is easy to cause clutch and shift institutions wear and failure
- Maintain and adjust the clutch should be performed by the designated company service units.
- The adjustment and maintenance of the clutch shall be carried out by a dealer authorized by ZONTES.

Clutch cable clearance

Adjustment progress:

- (1) Loose lock nut ①.
- (2) Turn the adjusting screw ② to adjust the clearance lasso, within the range of 0.5~1.0mm.
- (3) After completion of clearance adjustment, tighten the lock nut.

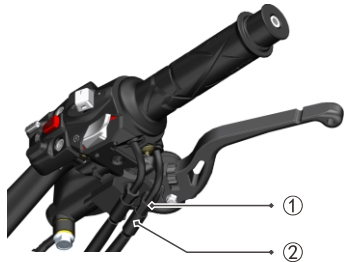

· After completing the clearance adjusting throttle cable, ensure the throttle hand turn automatically back to the closed position, do not make the engine idle speed by adjusting cable. It cannot appear the situation that the idling level is up when you turn the head of the motorcycle at the same time.

Idling Speed

When you check the engine idle speed, it should be performed under the hot condition of the engine. engine idle speed range should be between 1500 to 1700RPM.



· If the idle speed of engine is beyond the scope of regulation, please let the designated company service units to check the motorcycle.

Fuel Evaporation Pollutant Control System

Fuel evaporative pollutants control system

The motorcycle has a control system which can prevent fuel evaporation to the atmosphere. It should be regularly (every 10000km or every 30 months) do the following.

- (1) Check whether every connection is reliable .
- (2) Check each line and the activated carbon tank crack or damage, please replace the damage.
- (3) Confirm every line and activated carbon tank whether blocking, clear or replace if necessary.



· If the fuel evaporative pollutants control system need to check and maintain, we strongly advise you to give this work to a qualified repair units to do it.

USB port

Charge USB port data:

Input voltage: 12V-24V; output voltage: 5V; output current: 2A.

Characteristic:

1. Waterproof cover can prevent water and dust from getting inside to extend the usage life of the charger.
2. Intelligent IC design. It will automatically adjust the charging speed according to the battery volume and type.
3. With the protection of over voltage and current, we can make sure the safety of charging.



- USB must be covered with waterproof cover, when not in use, during raining time or washing of the bike. water is likely to cause damage to the internal components, If water enter the USB, dry before use by using a hair dryer to blow the USB port.
- Please don't use when there is not enough battery volume.

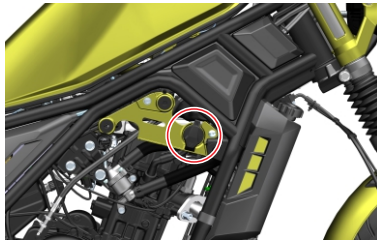

Drive chain

Drive chain

This model is equipped with a recirculating transmission chain made of special material. When it is necessary to replace the transmission chain, please leave this work to our maintenance unit. Check and adjust the transmission chain of the motorcycle before driving every day. Follow the instructions below for inspection and maintenance.



· In order to ensure safety, check and adjustment of transmission chain should be before driving.

Inspection of the drive chain

When inspecting the drive chain, check for the following problems.

1. Loose pins.
2. Damaged rollers, oil seal damage off.
3. Inflexible rotating chains.
4. Transitional wear.
5. Improperly adjusted chain, inconsistent left and right scale markings on rear flat fork.
6. Dryness, serious rust or serious dirt.
7. Whether the chain has reached the end of its service life.



· If it is found that there is something wrong with the drive chain or improper adjustment, please contact the authorized dealer of zontes for repair.

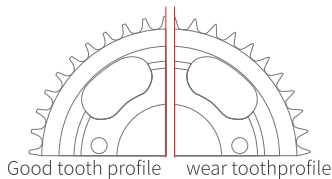

Drive chain

A worn transmission chain often means that the sprocket and the anti-friction block of the rear flat fork are also worn. Please check the sprocket and the anti-friction block of the rear fork for the following problems:

1. Whether sprocket for excessive wear.
2. Whether teeth are broken or damaged.
3. Whether sprocket fixing nut is loose or not.
4. Whether the anti-friction block of the rear flat fork is worn to the limit, and whether the rear flat fork has any traces of being worn by the chain.

If any of the above problems are found, please let our designated repair shop handle it.



· When checking or replacing the drive chain, the wear of the master-slave two drive sprockets and the rear flat fork anti-wear block should be checked and replaced at the same time if necessary.

Cleaning and lubricating the drive chain

Clean and lubricate the drive chain regularly as follows.

1. Remove dirt and dust from the chain.
2. Clean the chain with chain cleaner or water and neutral detergent, and use a fine soft brush to clean the dirt and dust on the surface of the chain rollers.
3. Wipe off the water and neutral detergent and dry the chain.
4. Use motorcycle chain oil or engine oil to lubricate the pins, rollers and inner and outer chain plates.
5. After fully lubricating the chain, wipe off the excess chain oil and let it stand for more than half an hour to allow the chain oil to fully penetrate and lubricate.
6. Keep the chain lubricated.

Adjustment of the drive chain

Adjust the slack in the drive chain to the proper range. Increase the frequency of drive chain adjustment according to driving conditions.



· If the slack in the drive chain is too large, the engine may be damaged if the chain comes off, or the rear fork may be deformed or broken due to cutting damage caused by a chain that has too much slack and is moving at high speeds, so check and adjust the slack in the chain when using the motorcycle.

Drive chain

Adjust the drive chain by the following steps for the double rocker arm:

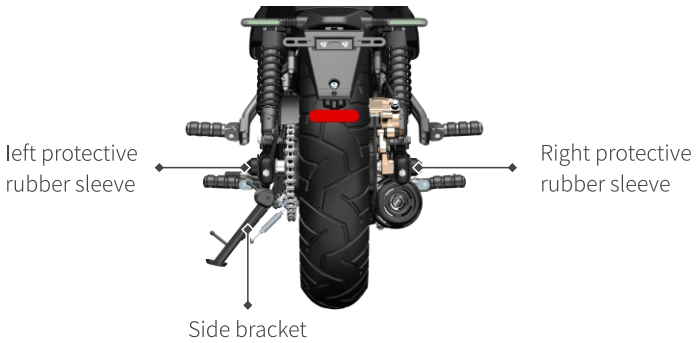

1. Remove the protective rubber covers on the left and right of the rear axle.
 2. Loosen (not necessary to completely unscrew) the rear axle bolts ① with a 19#, 21# spanner or socket.
 3. Lower the side stand to support the motorcycle.
 4. Adjust the adjusting nut ② with a 13# open-end wrench to a certain position so that the transmission chain reaches a suitable degree of slack. At the same time, to ensure that the front and rear of the wheel are in a straight line, adjust the left and right side scale plates to the same position as the scale markings on the rear flat fork.
 5. After completing the adjustment, re-tighten the rear axle nut and install the rear axle left and right protective rubber covers.
- Rear axle nut torque: **80 N.m.**

Drive chain



·The drive chain of this vehicle is made of special raw materials. It is highly recommended to use our chain for replacement of the drive chain. If you use other drive chains, if the strength is too low or the quality is low, the chain breakage may damage the vehicle or injure the personnel. If the chain is worn out and stretched to the end of its service life, it can not be removed and riveted together again, as it will seriously exceed the fatigue life of the chain, and the chain breakage may damage the vehicle or injure the personnel.

Check chain life.

Non-oil-sealed chain has a normal maintenance service life of 10,000 to 15,000 kilometers, with wear and tear stretched to the service life, please replace the chain in time:

1. Recommend to replace the original genuine 520 chain.
2. When using an open type of oil seal chain with a live joint, it should be riveted with a special tool, before riveting, it should be evenly coated with a special lubricant for the pin oil seal, and the oil seal and chain link should be clean and free of sundries. When riveting the hole, it is recommended to rivet the hole several times, the pinhole should not be broken or cracked, and the size of the hole must ensure that the links at the riveted joint rotate flexibly and the outer chain plate will not deviate or fall off in normal riding.

Check the life of the anti-friction block of the rear fork.

1. The service life of the anti-friction block of the double rocker arm rear fork is 10,000 to 20,000 kilometers, and it is recommended to replace the block when replacing the chain sprocket.
2. When replacing or checking the chain tension, the wear of the rear anti-friction block must be checked, if the rear anti-friction block is worn to thin by the chain, and there are deep grooves at the contact of the inner and outer plates of the chain which are close too wearing through, the rear anti-friction block must be replaced to prevent the rear anti-friction block from being worn through by the chain.

Brake system

This motorcycle front and rear wheel assembly of the disc brake. The right brake operation is very important for safe driving. Remember to regularly check the braking system, and the inspection qualified maintenance unit to complete.



- Brake is highly significant components of personal safety; you should regularly check and adjust the brake, and regular cleaning the sediment on the brake caliper etc, to prevent obstacles to the movement of the piston.
- If the brake system needs maintenance, we strongly advise you to give this work to a qualified maintenance unit. They have complete tools and skilled technology, and it is also the safest and most economical way to do the job.
- No regular inspection and maintenance of motorcycle brake system will increase the risk of accidents. Confirmed before each use of motorcycle according to the brake system content. In accordance with the requirements of the regular maintenance table to maintain the braking system.

According to the following to check the braking system:

1. Check the brake cylinder liquid level position.
2. Check for leaks the front and rear brake system.
3. Check whether the brake fluid hose leakage or rupture.
4. Check the brake disc and brake wear condition.
5. Operate the front and rear brake system to check whether is flexible and effective or not.



- The disc brake system is using high pressure brake. To ensure safety, the brake fluid hose and brake fluid replacement, shall not exceed this manual inspection and maintenance the rules of the verse.

Brake system

Check the brake fluid level position in front and rear brake fluid cylinder. If the liquid level in the LOWER (low) below the mark, check the brake wear and brake fluid leakage.

Braking fluid

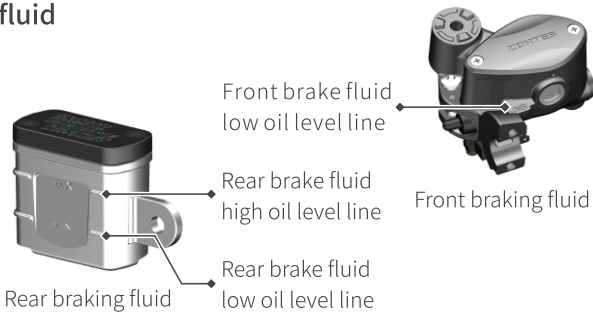

· Don't wash brake cylinder directly with high pressure water.
 · If swallowed into the brake fluid, it will cause harm to people, and even deadly. The brake fluid is harmful to both skin and eye contact. Brake fluid is toxic for animals. Don't puke if swallowed into the brake fluid. Immediately contact the poison control center or hospital. If the brake fluid gets into eyes, wash your eyes, and look for a doctor for help. Wash your hands thoroughly. Keep children and pets away from the brake fluid.



· The use of the brake fluid is mixed with water, dust and impurities, and silicate liquid or oil, or else they could seriously damage the braking system. Do not use the brake fluid in the open container. You can't use the brake fluid from the last maintenance either. You can only use DOT3 brake fluid. When brake fluid splashed paint surface or plastic surface, it will corrode the surface of the material.

Brake pads

Check that the front and rear wheel brake pads are worn to the extreme position. The extreme position refers to the bottom of the friction material groove. If it is worn to the limit position, please go to the maintenance shops and replace the front or rear brake pads in pairs.

Brake system



Rear\front wheel brake piece



· If fail to brake piece inspection and maintenance, don't change in time or in the recommended replacement, it will increase the risk of accidents. If brake piece need to be replaced, please let the designated company service units to complete the job. It must accord with the method recommended by brake piece inspection maintenance.

· If you drive the motorcycle after repairing the brake system or replacing the brake pads, and do not operate the front brake lever or the rear brake lever several times, the braking effect will deteriorate and an accident may occur. After repairing the brake system or replacing the brake pads, operate the front brake handle or rear brake handle several times until the brake pads can compress the brake disc, so that the front brake handle and rear brake handle return to normal hydraulic resistance.



· If you just change one pair of brake piece, it can cause the brake to not be smooth. You should replace a pair of brake at the same time.

· If the location of the brake piece is wrong, please do not operate the brake handle or the brake pedal. If you operate on brake lever or the brake pedal, piston is hard to reset, and it can lead to the brake fluid leakage.

Front wheel

Checking the front brake disc: Use a caliper to check whether the thickness of the friction surface of the brake disc is less than 4.0mm. If the thickness is less than 4.0mm, a new brake disc should be replaced.

Rear wheel

Checking the Rear brake disc: Use a caliper to check whether the thickness of the friction surface of the brake disc is less than 4.0mm. If the thickness is less than 4.0mm, a new brake disc should be replaced.

Brake system



· When you have just replaced a new brake disc pad, do not drive immediately. Grab the brake handle several times or pedal the brake pedal several times to make the brake disc and the brake pad fit together to restore the normal grip and stabilize the brake fluid circulation.

· After replacing the new brake disc or brake pad, the braking distance may be longer than the original braking distance. After 300km or so, the brake disc and the brake disc can be fully meshed to achieve better. Braking effect, before this, pay attention to leave enough braking distance when driving.

Rear brake pedal adjustment

The rear brake pedal should be kept in the proper position. Otherwise, the brake pads will always rub against the brake disc, which will damage the brake pads and disc. Adjust the position of the brake pedal as follows.

1. Loosen the lock nut ①, rotate the screw ②, and adjust the position of the brake pedal to the appropriate position on the top surface of the footrest. (factory preset at about 50.9 mm).
2. Tighten the locknut ① and make sure the screw ② is in the correct position.

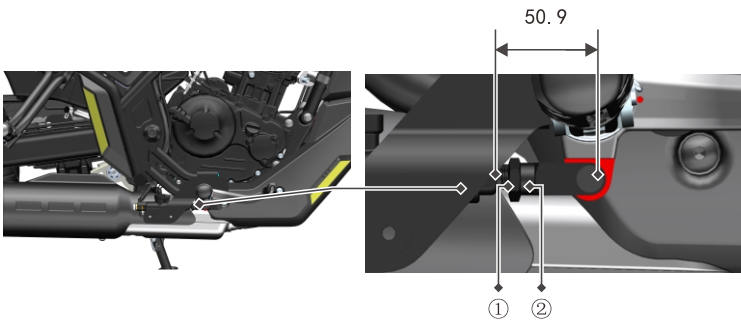

· If the adjustment is not correct, brake piece and brake disc will be forced all the time which can damage the brake and the brake disc, when it is severe it will lead to high temperature for the rear brake, produce gas resistance, the rear wheels lose braking force. Please adjusted brake pedal according to the content of this section correctly.

Tires



- Do not pay attention to the following matters may be accident caused by the failure of the tire. Tires connect the motorcycle and ground, so it is very important. Observe the following rule:
- Check the tires and tire pressure condition, adjust the tire pressure before each use.
- Avoid the motorcycle overload.
- Replace tires when tire wear to limit or tire surface has crack and wounds.
- Always use specifications and regulations provided in the instruction manual for the size of the tires.
- After installing tires, you should balance the wheels.
- Read carefully the content of the instruction.
- If tire running-in is not good, it will affect the occurrence of tire slip and lose of control. When motorcycle is using new tires, you must be driving carefully. According to the running-in-section in tires, avoid braking in the situation of nasty accelerated, a sharp turn, and emergency within 150 kilometers after the replacement of tires.

Tire pressure and load

- The right tire pressure and the right tire load is an important factor. Overload can lead to tire faulty and motorcycle will be out of control.
- Check the tire pressure, payload in accordance with the contents of the table below before using the motorcycle. You should check and adjust tire air pressure before driving, During driving, rear tires will fever, and tire pressure will rise.
- If tire pressure is too low will cause the difficulty of turning, it will also accelerates the tire wear. If the tire pressure is too high, the tire and ground contact area is reduced, it is easy to slip out of control.
- Recommended tire pressure under the normal temperature condition: 215kPa.



- Regularly check the tire pressure and keep it within the recommended atmospheric range .
- When feeling tire pressure drops, check whether there is a nail in the tire, small hole, round circle round (copper) profile is damaged. Tubeless tire is gradually deflated when small hole.

Tires

Tire storage

When the motorcycle is not in use for a period of time, it is necessary to adjust the tire pressure to the specified pressure.

The tire is rubber product of semi-hot melt formula, which is not suitable for outdoor weather in extremely cold, otherwise it will cause frost crack of the product. Please store it in a place with higher temperature or indoor.

Tire condition and specifications

Incorrect tire status and incorrect tire size affect the performance of the motorcycle. If there is any breakage in the tire scratches, it can lead to faulty tires and make the vehicle out of control. Excessive wear of tires can make tires perforation and the vehicle out of control. Tire wear is also affect the appearance of the tire, and change the operating performance of the tire. Check the state of tire and air pressure before each use. If there are much obvious damages on the tires, such as: damaged, scratched, or tire wear to limit position, you must replace tires.

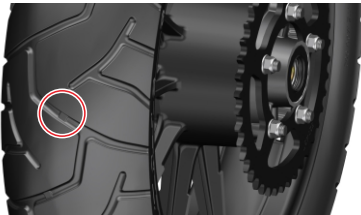

· The triangle labels the wear strip position. If the wear strip touches the ground, it shows that the tires have been wear to pass the limit. You have to replace the tires. When you replace the tires, make sure that the size and type of the tires is accorded with the list content below. If you replace it to different sizes or type, it will influence the performance of the motorcycle and may even lead to the loss of control for the motorcycle.

	Front wheel	Rear wheel
Specification	120/80-16	140/70-16



· It will cause problems if you use the tires which are out of the range of the standard. We really suggest you use the standard tires.

Tire removal

Front-wheel disassembly



Front-wheel axle tightening torque: 55N.m

Tightening torque of front axle locking bolt: 20N.m

Front caliper mounting bolt tightening torque: 25N.m

Front-wheel removal

1. Support the motorcycle with the special support bracket.
2. Loosen the 2 bolts ① connecting the front caliper on the front shock absorber and remove the front caliper.



· When you remove the front brake pliers, do not operate the brake controller. Operating the brake controller leads to brake caliper piston ejector, difficult to return; if forced to return, it can make the brake fluid leakage.

3. Loosen the axle locking bolt ③.
4. Place the special equipment under the engine and jack up the front of the motorcycle until the front wheel is just off the ground.
5. Turn the wheel axle ② counterclockwise and pull it out.
6. Move the front wheel forward.
7. Install the front wheel by doing the opposite of the above.
8. After installing the front wheel, operate the front brake handle several times to restore normal grip.



· After installing the front wheel brake, if the brake block position is not correct, it will affect the braking effect and may cause an accident. Before driving, operating brake controller for several times, until there is certain pressure to the brake disc when you grip it. Also, you can feel the handle grip force back to normal. Also check the wheel to see whether the rotation is flexible.

Tire removal

Rear Wheel Removal

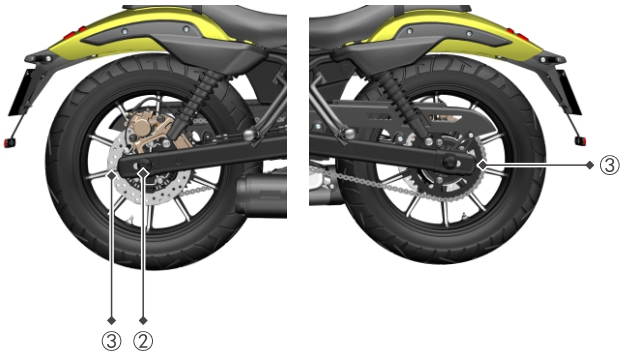

Rear Wheel Removal

Rear wheel:

Rear wheel axle nut tightening torque: 80N.m

Rear wheel disassembly

1. Support the motorcycle with the special support bracket.
2. Remove the two bolts ① and take off the rear sub-mudguard bracket.
3. Remove the rear wheel nut ②.
4. Loosen the left and right side drive chain adjusting nuts ③.
5. Pull out the rear wheel axle.
6. Move the rear wheel toward the front and remove the drive chain from the rear sprocket.
7. Remove the rear wheel toward the rear.
8. Install the rear wheel in the reverse order.
9. Adjust the drive chain
10. After installation, operate the brake pedal several times to check whether the rear wheel rotates flexibly.



· Remove the rear wheel, don't hit the brake pedal. Stamping on the rear brake pedal brake piece will make it difficult to return.

Tire removal



DANGER

· If the drive chain adjustment is incorrect, or shaft didn't tighten correctly, it can cause accident. After installation of the rear wheel, adjust the drive chain according to the transmission chain adjustment section for drive chain. Make sure the torque tighten the wheel nuts in accordance with the relevant provisions. If you don't know how to operate, please contact the authorized dealer of ZONTES for repair

· After installation of the rear wheel, brake position is not correct will affect the braking effect and may cause an accident.

· Before use, operating the brake pedal repeatedly, until the brake piece has certain pressure to the brake disc, you can feel the drag brake pedal returned to normal. Also check whether rear wheel rotation is flexible.

Lighting & Lamps

Please refer to the instruction of the front part “check before driving” for the illumination and signal inspection.

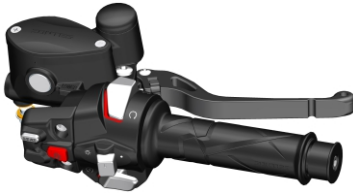

Front brake switch

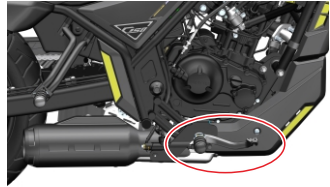

Rear brake switch

Front brake switch

The front brake switch locates on front brake lever. Braking lights are on when rider grab the brake lever with a slightly tight feeling.

Rear brake switch

The rear brake switch located in the bolt of brake hose. When you feel the pressure on the rear brake pedal slightly, the brake lights up.

Headlight bulb replacement

We use imported LED light product for the front light. In that case, we don't need to replace the lamp bulb during the usage life of the motorcycle since it is very durable.

Headlight Beam Height Adjustment

1. Loosen the headlight left and right mounting point bolts (Figure 1).
2. Adjust the headlight angle by hand, keep the headlight position unchanged after adjustment, and tighten the bolts.

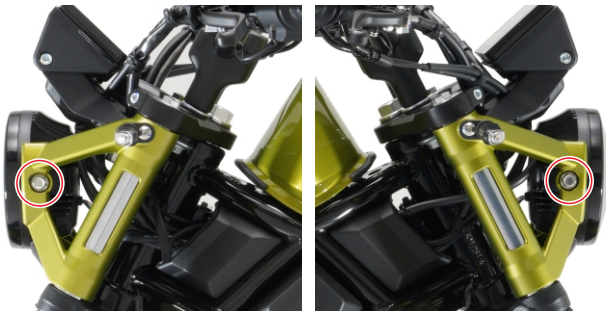

Fuses

Fuse wire

Main fuses, ECM fuses, constant power fuses, hydraulic unit motor fuses, hydraulic unit ECU fuses, light fuses, spare fuses are located in two main fuse blocks, starter fuses, ABS fuses, auxiliary fuses, and other fuses are located in the secondary fuse box.

1. The main fuse protects all circuits.
2. ECM fuse protects ECM, ECM relay, oil pump relay and other electrical components.
3. Constant power supply protection fan, instrument, anti-theft device connector.
4. Hydraulic unit motor fuse protection ABS hydraulic unit motor.
5. Hydraulic unit ECU fuse protection hydraulic unit ECU.
6. Light fuse protection headlights.
7. Start fuse protection start circuit.
8. ABS fuse protection ABS controller.
9. Auxiliary fuse protection auxiliary parts (position light, turn signal, tail light, brake light, license plate light, horn, overtaking light).
10. Other fuse protection deputy handle switch (except faucet lock switch), instrument, windshield, anti-theft device joint).



· **Don't use not-in-specification fuse wire or other direct lap. Otherwise it will have serious absence made of circuit system, or even cause fire or burning vehicles, loss of engine power, it is very dangerous.**

Accelerant

Catalyst can effectively cut your vehicle exhaust pollutant, the protection and preservation of our environment; Due to the life of the catalyst is under the precondition of normal use unleaded gasoline vehicle design, banned the use of leaded gasoline in the love of your motorcycle, because lead can make a reduction of the catalyst is also very important, if the engine is not effective when the ignition or without adequate cooling, will cause the exhaust gas gathered in catalytic combustion, catalytic overheating caused permanent damage to the catalytic conversion ability, banned in any sens long maintain high engine speed.

Troubleshooting

The content of the troubleshooting can help you to find the cause of the general issues.



- **Improper maintenance and adjustment can damage the motorcycle and cannot determine the cause of the problem. We can't guarantee such damage. If you are not sure how to correct operation, consult the designated company service units.**
- **Before the troubleshooting, best to consult the company repair units. Repair units will try to solve for you.**

Fuel system check

If instrument engine fault indicator light is on, there is something wrong with the fuel injection system. You should send the motorcycle to the designated company service units. Refer to instrument a section of the content of the engine failure indicator, it shows the interpretation.

Engine not working

1. Remove the spark plug, and connect to the spark plug cap.
2. Place the spark plug on the engine, turn on the red power button, place the engine stop switch at the  position, support the main bracket, and hold the brake handle. Press the electric start button, if the ignition system works normally, the spark plug electrode will emit a blue spark. If there is no spark, contact our company's maintenance unit for repair.



- **Do not put the spark plug fixed near the spark plug hole to make the inspection. Because of the combustible mixture in the cylinder may be ignited by a spark and fire.**
- **In order to reduce the possibility of electric shock, and spark plug shell metal parts, with best posted near to the parts without painting.**
- **To avoid the possibility of electric shock lead to disaster, people who have heart disease or wear heart pacemaker should avoid doing this job.**

Troubleshooting

Engine inoperation

1. Make sure the fuel tank has enough fuel
2. When you successfully start the engine, in the process of engine running, it shows abnormal situation when the orange fuel injection signal light is on. In that case, please contact after-sales dealership to check your fuel injection system.
3. Check whether the ignition system is normal.
4. Check the idle. The correct idle speed of 1400-1600 revolutions per minute.



· Don't make the fuel flow everywhere, the container should be income. don't let fuel close to high temperature of the engine and the muffler. When doing the inspection, it should be far away from the fireworks, also don't close to fire and heat source.

Engine short of power

When engine power significantly decreased or a larger decline on original top speed, it may be the blocking of the engine fuel system make the work of engine is not normal, please immediately go to the company dealers maintenance unit for inspection.



· Fuel system block is probably because of the not clean gasoline.

Carbon Cleaning

In order to generate as little carbon as possible, the recommendations are as follows:

1. The motorcycle rides for a short time or for a long time or for a long time under 5000 rpm. It is recommended to clean the carbon deposit every 5000 kilometers or every 6 months. If the motorcycle often rides at more than 5,000 rpm, the motorcycle's heat engine is also sufficient, and the mileage for cleaning up carbon deposits can be extended to every 10,000 kilometers or every 12 months.
2. The motorcycle has difficulty in starting. Remove the spark plug for cleaning in time, and perform the cylinder cleaning procedure. Press the start button for 3 seconds when the clutch is fully opened.

Troubleshooting

There are several ways to clean up carbon deposits:

1. Scavenging to clean up carbon deposits. During riding, when conditions permit, appropriately increase the throttle at high gears to increase the engine speed to more than 7000, and the cumulative riding is not less than 2 minutes, which can effectively clean up the deposits by high-speed scavenging.

2. Use standard brand fuel oil to clean up carbon deposits and add according to the instructions, but it is not recommended for frequent use. Frequent use may cause damage to the fuel supply pipeline.

3. Use throttle body cleaner to clean up carbon deposits, remove the stepper motor and three-in-one sensor from the throttle body, spray a small amount of throttle body cleaner into the throttle body and around the valve plate, and use a clean rag to clean up carbon deposits on the motor head.



WARNING

· The remaining sensors must not be disassembled by yourself, otherwise it will cause the vehicle to idle abnormally, if you need to disassemble and troubleshoot, please contact the after-sales guidance for it.

EFI Precautions

Fuel injection attention:

1. Before the installation of battery for new motorcycle, we should inspect that whether the connection for the fuel injection spare parts is fixed and reliable including the installation of oxygen sensor. Moreover, make sure to fill in the gas.

2. When you install the battery, you should use tools to fix the positive and negative anodes according to the positive and negative anodes of battery. Do not tie it up by hand.

3. Please keep the gas level to not less than 3 liter in the fuel tank; otherwise it will influence the normal working of fuel injection system. In that case, please refill the gas when the gas level is lower than or equal to level 1.

4. When the battery is reinstalled, the motorcycle is powered off during startup or riding, the battery is restarted when the battery is dormant, the idle speed is abnormal, and the fuse is re-plugged, please pay attention to reset the individual hardware of the EFI. The steps are: open Electric door lock and engine shut-off switch, support the main bracket and squeeze the brake, start the engine and refuel above 3000rpm, release the throttle, then close the shut-off switch and electric door lock, and then power on after 5s.

5. If the motorcycle is not driven for a long time (parking time is more than 3 hours), please make sure that the fuel pump has completed accumulating pressure before starting for the first time (that is, the bike is powered on, the flameout switch is turned on, and the buzzing in the fuel tank stops) before starting.

6. If after several tries, you cannot still start, it might be the situation that the cylinder occupied by water. We should take the clear cylinder process. Turn the throttle line all the way down to full open, and then turn on te switch for 3 seconds.

7. If the battery voltage is flashing on the instrument, it indicates that the voltage level is too low, please recharge the battery at once; low voltage will lead to the abnormal working condition of the fuel injection spare parts so that the motorcycle won't start or the power is not enough.

EFI Precautions



· For new motorcycles or motorcycles which have no fuel inside the fuel tank, please don't turn off the switch. It got to refuel some level of fuel before you turn off the switch. Otherwise, the fuel pump will rotate without fuel so as to lower the service life for the fuel pump.



· Please do not unplug the cable port of all different spare parts and do not clean it with water.

1. When the engine is running, if the EFI failure indicator on the instrument is on, it indicates that there is a fault in the EFI component that needs to be eliminated.

a. Turn the throttle to the maximum before energizing the motorcycle and keep it in the fully open position, then turn on the electric lock and engine switch. If the system detects a fault, the fault light will start to flash.

b. The fault code has 4 digits. Read the fault code according to the number of flashes. For example: P0201 flashes in the following ways: continuous flashing 10 times → pause 1 second → continuous flashing 2 times → pause 1 second → continuous flashing 10 times → pause 1 second → continuous flashing 1 time.

c. If there is more than one fault, the next fault code will flash after the fault light is off for 4 seconds. Therefore, after the fault light is off during the flashing process, waiting for more than 5 seconds and still no longer lights up, it means that the fault code has been flashed.

d. If you need to observe the flashing code again, you need to turn off the engine switch first, then turn it on again, and keep the throttle fully open.



· For new cars or vehicles that have run out of fuel, please do not turn on the flameout switch. Be sure to turn on the flameout switch after refuelling, otherwise the fuel pump will be seriously idling.



· Do not plug and unplug the cable plugs of each part at will, and do not clean the cable plugs of the electric injection parts without water.



· During the operation of the engine, the fault light is not on: after the engine is turned off, the fault light flashes, which is a historical fault and has no impact on the whole vehicle, and will disappear by itself in the future.

EFI Precautions

Code	Description
P0030	Upstream 1 cylinder oxygen sensor heating control is open circuit
P0031	Upstream 1 cylinder oxygen sensor heating control circuit voltage is too low
P0032	Upstream 1 cylinder oxygen sensor heating control circuit voltage is too low
P0106	Intake pressure sensor/barometric pressure sensor is unreasonable
P0107	Intake pressure sensor is short circuit to ground
P0108	Intake pressure sensor is short circuit to power supply
P0112	Intake temperature sensor signal voltage is too low
P0113	Intake temperature sensor signal voltage is too high
P0134	Upstream 1 cylinder oxygen sensor circuit signal failure
P0201	1 cylinder injector control is open circuit
P0261	1 cylinder injector control circuit is short circuit to ground
P0262	Intake pressure sensor is short circuit to power supply
P0322	Speed-Sensorless pulse signal (open circuit or short circuit)
P0511	Idle speed actuator control is open circuit
P0563	System battery voltage is too high
P0116	Engine coolant temperature sensor signal is unreasonable
P0117	Engine coolant temperature sensor circuit voltage is too low
P0480	Fan control is open circuit
P0691	Fan control circuit is shorted to ground
P0692	The fan control circuit is short circuit to the power supply
P0118	Engine coolant temperature sensor circuit voltage is too high
P0122	Throttle position sensor circuit voltage low limit
P0123	Signal of the upstream 1 cylinder oxygen sensor is unreasonable
P0130	Signal of the upstream 1 cylinder oxygen sensor is unreasonable
P0131	Signal of the upstream 1 cylinder oxygen sensor is too low
P0132	Signal circuit voltage of the upstream 1 cylinder oxygen sensor is too high

EFI Precautions

P0627	Oil pump relay control circuit is open
P0629	Oil pump relay control circuit is short circuit to the power supply
P0650	MIL lamp driver stage circuit failure
P0444	Canister solenoid valve open
P0459	Canister solenoid valve is shorted to power supply
P0458	Canister solenoid valve is shorted to ground
P2300	1 cylinder ignition coil is shorted to ground
P0628	Oil pump relay control circuit voltage is too low
P1098	Dump sensor signal voltage is too low
P1099	Dump sensor signal voltage is too high



· When the engine is running, broken light is not on. When you turn off, the signal light is flashing. It means that is historical error and it has nothing to do with the whole motorcycle. After that it will disappear.

Adding electrical parts

Addition of electrical components

The original motorcycle has been equipped with a modification port: as shown in the picture, the modification port is located under the fuel tank, there is a plug-in connector and wire, and you can directly connect to the plug-in wire, start the engine in order to power on, without destroying the original wiring can be retrofitted with spotlights.

 ATTENTION

- It is forbidden to use GPS, spotlights and other electrical equipment to directly take power on the positive and negative poles of the battery.
- Not allow electrical equipment to put wiring around the battery.
- Installed electrical equipment must be kept away from the EFI ECU, relay combination, PKE controller 300mm or more
- Unauthorized breakage modification and installation location do not meet the requirements, and the consequences are borne by owners
- The total power of external electrical equipment shall not exceed 60W, and do not use spotlights when idling

Security device plug: As shown in Figure 2, there is an anti-theft device plug (6pin) reserved inside the left tail skirt, which can be used to install anti-theft device or GPS and other electrical devices. The wire colors and definitions are:

No.	line color	Definition
1	blue and white	engine speed signal
2	red	power supply 12V
3	green	power supply 0V
4	light blue	right turn signal
5	orange	left turn signal
6	Black	ACC 12V

In addition, two red short-circuit single lines are reserved for emergency assistance.

Adding electrical parts



Storage Methods

Storage method

If you are not using motorcycle for a while, the motorcycle needs special maintenance, this requires some special materials, equipment and technology. For this reason, it is recommended that you choose the company service units to complete the maintenance work. If you want to complete the work, please click the following method:

Motorcycle

Thoroughly clean the motorcycle. Use the main parking stand to park the motorcycle on a flat ground. The handlebars to the left, long press the button of red power-on button, the motorcycle will be electrically cut off, the head lock will be also locked automatically.

Fuel

With the method of the siphon or other appropriate approach to pull out the fuel from the fuel tank into the appropriate containers.

Engine

- 1.Remove the spark plug, put a tablespoon of oil into each of the spark plug hole, reinstall the spark plug, and let the engine crankshaft rotate for several rounds.
- 2.Through dry the oil, and add new oil again.
- 3.With cloth containing new oil to cover the new oil filter of the air inlet and exhaust muffler to avoid

Storage battery

- 1.Remove the battery refer to the content in battery section.
- 2.Use neutral soap water to clean surface of the battery, remove rust from the terminals and wiring connector.
- 3.Storage the battery indoor where the temperature is over 0°C.

Tires

Adjust the tire pressure to the regulated pressure.

The surface of motorcycle

Put rubber protective coating on the surface of resin and rubber parts.

The antirust paint spraying on the surface of the parts that have no surface treatment.

Use the car wax coating paint the surface.

Maintenance during storage period

Please use our dedicated charger to charge the battery once a month.gel battery charger charging: 4A × 3 ~ 5 hours (charging voltage 14.5V ~ 14.8V). The batteries can not be charged for more than 5 hours.

Storage Methods

How to restart

1. Clean the motorcycle completely.
2. Remove dishcloth for air filter and the intake muffler exhaust.
3. Pull off all the engine oil. According to this instruction manual related content, replace the oil filter and add new engine oil.
4. Remove the spark plug. Let the engine turned several rounds. Reinstall the spark plug.
5. Reinstall the battery referring to battery content section.
6. Make sure motorcycle lubrication is normal.
7. Inspect the motorcycle in accordance with the content of instruction for use in the inspection section before driving.
8. Restart the motorcycle in accord with the instruction.

Corrosion prevention

Maintain the motorcycle carefully. Corrosion prevention is very important. In doing this, your motorcycle will look like new even after many years.

Key points to prevent corrosion

Factors that lead to corrosion:

Salt road salt, the accumulation of dirt, moisture and chemicals.

Small stones or gravel damage on the surface of the painting, or by knock against scratches.

Salt road, wind, industrial pollution and high humidity environment will lead to rust.

How to prevent corrosion

Clean the motorcycle at least once a month. Try to keep the motorcycle clean and dry at your best.

Remove dirt on the surface of the motorcycle. Salt road salt, chemicals, asphalt and materials such as SAP, bird droppings, and industrial emissions will damage your motorcycle. Remove the dirt as soon as possible. If it is hard to clean with water, use detergent to clean. When using the cleaning agent, you must comply with cleaner product requirements.

Clean up the damage as soon as possible. A careful examination of the motorcycle on the surface of the paint damage is a must. If you find any burr or scratches, immediately repair it, avoid damage more. If the burr and scratch is throughout the surface of parts, please let the designated company maintenance unit to maintain it.

Storage Methods

Put the motorcycle in dry and ventilated place. If you often wash the motorcycle in the garage, and parked inside, the garage will become very wet. High humidity can increase the corrosion. If air does not flow, even in high temperature environment, damp motorcycle will rust.

Cover the motorcycle. Avoid the sun at noon to shine upon the motorcycle, it would lead to paint, plastic color changed or fade. Using high quality and breathable cover can avoid the sun ultraviolet radiation hit on the motorcycle, and reduce air pollution and dirt deposition on the motorcycle. Distribution unit of the company can help you choose your motorcycle cover.

Inspection after cleaning

Clean the motorcycle

Clean the motorcycle accord with the following:

1. Use cold water to wash away dirt and mud on the surface of the motorcycle. You can use the soft sponge or soft brush to clean. You could scratch appearance parts with hard materials to clean.

2. Use neutral detergent or a car wash soap, thoroughly clean sponge or soft cloth motorcycle. Sponge or soft cloth should be frequent infiltrate cleaning agent.

If you use the motorcycle in salt road surface or the beach, after use, you **should wash it in cold**

water immediately. You must use cold water. Hot water will accelerate corrosion.

Avoid spray cleaning, avoid water flow to the following location:

Ignition lock , Ignition plug , Fuel tank lock , Fuel injection system ,
Braking fluid tank



· Don' t use high-pressure water to clean the motorcycle, throttle body and oil injector.

3. After cleaning the surface dirt , use water to rush residual cleaning agents

4. After rinse, wipe the motorcycle with wet soft leather or cloth, and dry in the shade.

5. Carefully check the paint surface. If it has any damage, follow these steps, use repair material to repair the damage surface:

a. Clean and dry the area of damage

b. Stir repair material and use small brush to smear lightly at the site of the injury

c. Thoroughly dry the patch

6. Regularly check the cleanliness of the surface of the small water tank. If there is serious mud accumulation, you need to use cold water and a soft brush to clean the surface. Be careful not to damage the heat sink on the surface.



· After cleaning motorcycle or rain when you drive, there will be water mist in headlamps. Open the front light, water mist will gradually dissipate. Start the engine to power the headlamps; clear water to avoid the battery discharge.

Inspection after cleaning



· When you cleaning the motorcycle, don't use cleaner containing alkaline and acidic detergent, do not use gasoline, brake fluid, or other solvents which can damage the motorcycle. You can only use soft cloth with neutral detergent with warm water.

Motorcycle waxing

After cleaning, it is recommended that the waxing polishing, which not only it can protect the parts, but also it makes the parts more beautiful.

Use high quality wax and polish

When using wax and polish wax and polish matters, you need to pay attention on the use instruction of the products.

Inspect the problem after the use of the motorcycle accord with the instruction.

Transportation

Motorcycle fuel must be discharged before transport. Fuel is easy to combust and under certain conditions it can cause explosion. When drain the fuel, storage fuel or injected fuel, it is forbidden to open fire, be sure to stop the engine, to operate in a well-ventilated place. Drain fuel as follows.

(1) Stop engine rotation, and shut down the electrical door lock switch.

(2) With the method of the siphon or other appropriate approach to pull out fuel from the fuel tank and put into the appropriate containers.



· When shipping the motorcycles, the fuel in the fuel tank must be discharged clean to prevent fuel leakage and explosion .The vehicle should be shipped in a normal riding posture to prevent oil leakage from the outlet of the reducer box during shipping.

Cleaning the motorcycle

c. Do not overcharge the battery. Overcharging will cause the battery to leak, bulge or even burst, which will cause varying degrees of danger.

3. Attention

3.1 This battery is a maintenance free gel battery. It is strictly forbidden to open or modify the battery without permission. Do not add electrolyte or water without permission. It is strictly prohibited to put it in a place with high temperature and open flame.

3.2 When using and charging gel batteries, it is strictly forbidden to approach an open flame, and avoid short-circuiting of the positive and negative electrodes and loosening of the positive and negative terminals to prevent the battery from exploding.

3.3 During use or charging, the battery has a peculiar smell, severe heat, discoloration, or deformation.

Please remove the battery from the car body or the charger and stop it immediately

3.4 The gel battery is standard for motorcycles, please do not use it for other purposes than the start of the motorcycle..

3.5 The installation of external devices such as security devices, GPS, spotlights, etc. will have a certain impact on the battery and the circuit of the motorcycle. Adding qualified brand products must be selected and connected to the reserved interface of our company. Do not change the wiring privately, otherwise it will cause The circuit system of our vehicle may work abnormally and cause the gel battery to be over-discharged.

3.6 Do not drop the battery. The electrolyte contains sulfuric acid. Avoid splashing on the skin, eyes and clothes. Once in contact, please wash with plenty of water and send to hospital for treatment.

Fuel consumption

"Consumption" of powered by fuel motorcycle, refers to the vehicle with the fuel consumption at least one driving speed constant speed.

Each vehicle will be equipped with "vehicle parts list" and it is also available for you to get the electronic version from our official website.

Cleaning the motorcycle

1 The start of the new storage battery

Storage battery installation

a. Before installing the battery, check the appearance of the battery. The outer casing should be free of scars or cracks, the battery cover should be well sealed, and there should be no leakage, and the terminals should be free of skewing, deformation, etc.

b. After tightening bolts on the bolt, nut, terminal butter or vaseline, to avoid poor contact rust.

2 Use and maintenance

2.1 Each electric start-up time not more than 5 seconds, if you continue trying a few times and it can't start, you should check the oil supply system and starting, ignition system.

2.2 The following conditions will cause the gel battery to be over-discharged or under-charged to shorten the battery life:

a. Frequent electric start.

b. Short riding time and short driving distance.

c. No ignition after long-time startup.

d. Install additional electrical devices, such as high-power spotlights, audio, GPS and other electrical equipment.

2.3 If the starter motor is weak, the light is dim, the horn sounds hoarse, and the ignition appears black screen restarts and other abnormal phenomena, the battery should be recharged immediately.

2.4 When the motorcycle is not in use for a long time, the battery should be removed and stored separately, or the battery cable should be disconnected. Please recharge the gel battery before stopping the motorcycle, and recharge it once a month.

2.5 Charging Precautions:

a. When charging, please use the special charger provided by our company for charging. You can use the motorcycle's own charging port or remove the battery to charge separately.

b. When charging, try to refer to the following charging instructions to avoid high-voltage and high-current charging to extend the battery life.

c. within the range of 0.5-0.8 times the battery capacity value.

Note: When the usage is different from the above, the charging current must not exceed the specified charging current range, and the charging time must not exceed 24 hours.

155C2-Specification sheet

Length	2175mm
Width	845mm
Height	1120mm
Wheel base	1485mm
Ground clearness	150mm
Seat height	700mm
Full load weight	153kg

Engine

Type	Single cylinder, vertical, four-stroke, water-cooled
Cylinder number	1
Cylinder bore	58.0mm
Stroke	58.7mm
Displacement	155ml
Compression ratio	12.5:1
Start-up mode	Electric starting
Lubricating system	Splash lubrication plus pressure lubrication
Power	13kW

Transmission system

Clutch	Wet-type multiple-piece
Transmission	6 gears tooth transmission
Forward gear	3.333
Gear ratio 1 gear	3.273
2 gear	2.133
3 gear	1.526
4 gear	1.238
5 gear	1.043
6 gear	0.920
Transmission chain	Oil-seal chain

Main performance index

Fuel consumption	1.8L/100km
Maximum speed	113km/h

155C2-Specification sheet

Travel system

Steering angle	-----	37°
Front wheel specification	-----	120/80-16 vacuum tire
Rear wheel specification	-----	140/70-16 vacuum tire
Electric System ignition method	-----	discharge
Spark plug type	-----	CPR8EA-9
Storage battery specification	-----	12V, 9Ah
Fuse wire specification	-----	10A/15A/25A
Headlight specification	-----	12V,23W/15W
Front position light specification	-----	12V,1.3W
Turn signal light specification	-----	12V,2.2W
Tail lights/brake lamp specifications	-----	12V,1.68W/4.3W
Rear license plate lamp specifications	-----	12V,0.4W

Volume

Effective Fuel tank volume	-----	16 ± 0.5L
Engine oil volume	-----	1300mL
Engine oil, replace the oil filter at the same time	-----	1050mL
Engine oil, don't change the oil filter	-----	1000mL

125C2-Specification sheet

Length	2175mm
Width	845mm
Height	1120mm
Wheel base	1485mm
Ground clearness	150mm
Seat height	700mm
Full load weight	153kg

Engine

Type	Single cylinder, vertical, four-stroke, water-cooled
Cylinder number	1
Cylinder bore	52.0mm
Stroke	58.7mm
Displacement	125ml
Compression ratio	12.5:1
Start-up mode	Electric starting
Lubricating system	Splash lubrication plus pressure lubrication
Power	10.8kw

Transmission system

Clutch	Wet-type multiple-piece
Transmission	6 gears tooth transmission
Forward gear	3.333
Gear ratio 1 gear	3.273
2 gear	2.133
3 gear	1.526
4 gear	1.238
5 gear	1.043
6 gear	0.920
Transmission chain	Oil-seal chain

Main performance index

Fuel consumption	1.8L/100km
Maximum speed	99km/h

125C2-Specification sheet

Travel system

Steering angle	37°
Front wheel specification	120/80-16 vacuum tire
Rear wheel specification	140/70-16 vacuum tire
Electric System ignition method	discharge
Spark plug type	CPR8EA-9
Storage battery specification	12V, 9Ah
Fuse wire specification	10A/15A/25A
Headlight specification	12V,23W/15W
Front position light specification	12V,1.3W
Turn signal light specification	12V,2.2W
Tail lights/brake lamp specifications	12V,1.68W/4.3W
Rear license plate lamp specifications	12V,0.4W

Volume

Effective Fuel tank volume	16 ± 0.5L
Engine oil volume	1300mL
Engine oil, replace the oil filter at the same time	1050mL
Engine oil, don't change the oil filter	1000mL



WWW.ZONTES.COM