

310-V 前脚踏安装卡 310-V installing card of front footrest



注意事项
ATTENTION

ZT310-V前脚踏出厂前安装在最后面位置, 变档杆调节螺杆和后刹车主泵叉形接头延长杆放在配件箱。

Cautions: ZT310-V front footrests are installed at the backmost position before sending out the vehicle, adjusting lever of Gear shift lever and extension lever of rear brake main pump are put inside the accessory box.

一、调节前左脚踏位置(以脚踏调到中间位置为例)

Position adjustment of front left footrest(Take the footrest adjusted to the middle position as an example)

工具:12号梅花扳手、8号开口扳手、10号开口扳手

Tool:12# ring wrench,8# open wrench,10# open wrench

1. 拧下脚踏支座后面的M8x45螺栓①;
Remove the M8x45bolt behind the footrest support ①
2. 加装前挡泥板衬套②, 打紧脚踏支座后面的M8x45螺栓①;
Install the bushing of front fender ②,tighten the M8x45 bolts behind the footrest support ①

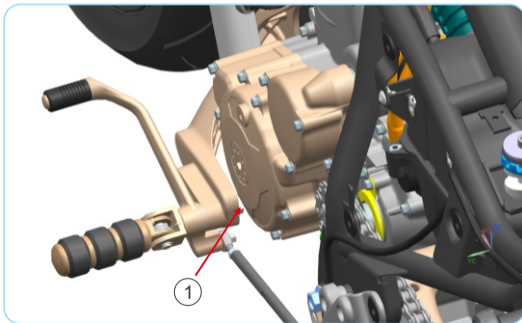

3. 脚踏装最前面位置时, 按上面的方式在调节螺杆前多加装一个前挡泥板衬套②, 起到延长调节螺杆的作用。
When the footrest is installed at the front position, pls install an extra front fender bushing ② in front of the adjusting screw as the step 2 does, which extends the adjusting lever.

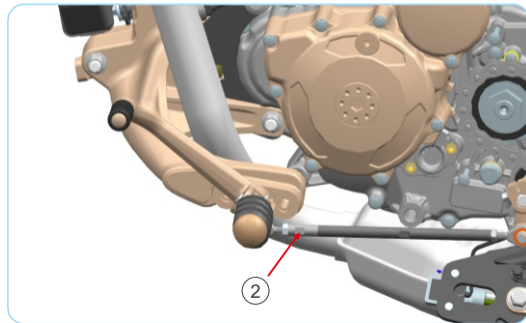

二、调节前右脚踏位置

Position adjustment of front right footrest

工具:12号梅花扳手、10号开口扳手、14号开口扳手

Tool:12# ring wrench,10# open wrench,14# open wrench

1. 拧下脚踏支座后面的M8x45螺栓①;

Remove the M8x45bolt behind the footrest support ①

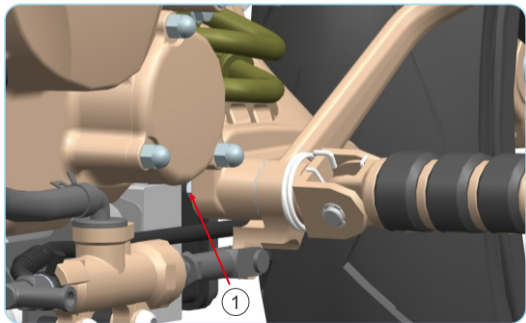

2. 前右脚踏装到中间位置:松开锁紧螺母②,旋转螺杆③,将刹车踏板位置调到合适高度后打紧锁紧螺母②。

Steps to install the front right footrest to the middle position:loosen the nut ②,rotate lever ③,and adjust the brake pedal to the appropriate height,then tighten nut ②.

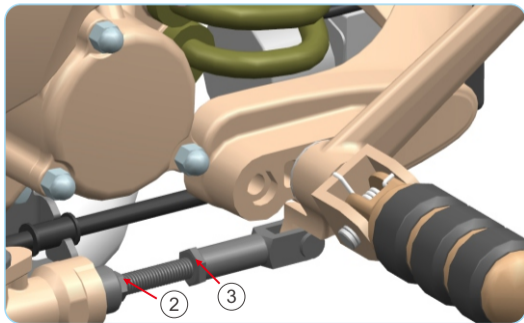

3. 前右脚踏装到最前位置:在步骤2的基础上加装ZT310-V后刹主泵活塞推杆加长杆④。

Steps to install the front right footrest to the front position: install ZT310-V extension rod ④ on the basis of step 2.

