

CONTENTS

CONTENTS	PAGE
0 CONTENTS.....	1
1 FRAME&ELECTRONIC PARTS COMPONENT	
1.1 Electronic parts component-1..... Main wire harnessk,Dump switch,Relay,Flasher,Rectifier,Ignition coil	5
1.2 Electronic parts component-2..... Shut-off switch,Horn	6
1.3 Frame plastic parts..... Tuck loop,side cover circle rubber cushion,inner fuel tank fix rubber cushion	7
1.4 Frame,Side support,the operation of releasing engine oil..... Side support,Frame drain bolt assembly	8
1.5 Steering rack component..... Down connected plate	9
1.6 Rear pedal component..... Rear pedal component	10
2 FRAME&ENGINE COMPONENT	
2.1 Frame&engine component..... Hanging piece,Bracket,Sprocket cover	11
3 INDUCTION SYSTEM COMPONENT	
3.1 Induction system component..... Throttle body module,Air filter,Oil pipe	12
3.2 Carbon Tank component..... Carbon Tank ,Carbon Tank solenoid valve	13
3.3 Replace the air filter element.....	14
4 REAR TIRE ,REAR FORKLIFT COMPONENT	
4.1 Rear inner mudguard.....	15
4.2 Rear shock absorber..... Dismantled rear shock absorber, Rear shock absorber adjustment	16
4.3 Rear tire module..... Dismantled rear rim module,rear forklife,Wheel axle	17
4.4 Rear rim component..... Dismantled rear rim component	18
4.5 Rear forklift component..... Dismantled rear forklift component	19
4.6 Replace rear brake block.....	20
4.7 Add the brake oil to the main pump or rear brake.....	21

CONTENTS

CONTENTS	PAGE
5 PEDAL COMPONENT	
5.1 Pedal height adjustment.....	22
Height adjustment of gearshift lever and brake pedal	
5.2 Right pedal support component-1.....	23
Dismantled right pedel support componet	
5.3 Right pedal support component-2.....	24
Dismantled the right pedel support componet	
5.4 Left pedal support component-1.....	25
Dismantled left pedel support componet	
5.5 Left pedal support component-1.....	26
Dismantled the left pedel support componet	
6 RADIATOR SYSTEM COMPONENT	
6.1 Release the engine oil.....	27
6.2 The oil pipe near the frame.....	28
Dismantled the oil pipe near the frame	
6.3 Radiator component-1.....	29
Dismantled the radiaor component	
6.4 Radiator component-2.....	30
Decomposition of the radiaor component	
7 FRONT FORK COMPONENT	
7.1 Front tire component.....	31
Dismantled the front tire component	
7.2 Front tire wheel speed sensor component.....	32
Dismantled the front tire wheel speed sensor component	
7.3 Front mudguard component.....	33
Dismantled the front mudguard component	
7.4 Head parts component-1.....	34
Dismantled head parts component	
7.5 Head parts component-2.....	35
Dismantled the front turning light and head light rear cover	
7.6 Head cover upper parts component-2.....	36
7.7 Head light component.....	37
7.8 Meter component.....	38
7.9 Meter function description.....	39
7.10 Front shock absorber.....	40
7.11 The adjustment of accelerator/clutch cable.....	41
Adjusted the throttle cable and clutch cable	
7.12 Replace the clutch cable.....	42
7.13 Replace the throttle cable.....	43

CONTENTS

CONTENTS	PAGE
7.14 Replace cushion cable.....	44
7.15 Right handlebar component.....	45
Dismantled right rearview mirror,right handlebar glue sleeve	
7.16 Add brake fluid,adjust the swing arm.....	46
Add brake fluid,adjust the brake swing arm	
7.17 Replace front brake block.....	47
7.18 ABS brake system-1.....	48
Dismantled the front brake calipers and ABS protection cover	
7.19 ABS brake system-2.....	49
Dismantled the ABS control system component and the main pumb of disc brake	
7.20 ABS brake system-3.....	50
Dismantled the rear brake calipers and discomposed the ABS control system component	
7.21 Left handle bar component,adjust the swing arm.....	51
Dismantled rearview mirror,right handlebar glue glove, balance blocks and combination lock	
7.22 Handle bar ,upper connected plate component.....	52
Dismantled the Handle bar ,lock block,upper connected plate component and combination lock	
7.23 Steering adjustment.....	53
Adiust steering device	
8 FUEL TANK COVER	
8.1 Fuel tank middle cover assembly.....	54
Dismantled Fuel tank middle cover assembly	
8.2 Fuel tank middle cover、 Fuel tank cover、 Fuel tank lock.....	55
Dismantled Fuel tank middle cover、 Fuel tank cover、 Fuel tank lock	
8.3 Fuel tank left and right cover assembly.....	56
Dismantled Fuel tank left and right cover assembly	
9 INNER FUEL TANK COMPONENT	
9.1 Inner fuel tank component.....	57
Dismantled inner fuel tank component and cushion fixed block	
9.2 Inner fuel tank.....	58
Dismantled inner fuel tank and fuel pump	
10 SIDE COVER COMPONENT	
10.1 SIDE COVER COMPONENT.....	59
Dismantled SIDE COVER COMPONENT	
11 REAR COVER、 REAR MUDGUARD、 ELECTRICAL DEVICE BOX COMPONENT	
11.1 Rear handrail、 Cushion lock bracket.....	60
Dismantled Rear handrail、 Cushion lock bracket、 Rear cover left limit bracket	
11.2 Rear mudguard assembly.....	61

CONTENTS

CONTENTS	PAGE
Dismantled rear mudguard assembly	
11.3 Rear mudguard subassembly.....	62
Dismantled rear mudguard、Rear license plate light、turn signal light	
11.4 Rear mudguard bracket assembly.....	63
Dismantled rear mudguard bracket、Rear mudguard bracket panel	
11.5 Battery、Electrical device box cover、ECU.....	64
Dismantled Battery、Electrical device box cover、ECU、Motorcycle tool	
11.6 Rear cover、Tail light assembly.....	65
Dismantled Rear cover、Tail light assembly	
11.7 Electrical device box assembly.....	66
Dismantled Electrical device box assembly	
12 CUSHION COMPONENT	
12.1 Cushion.....	67
Dismantled cushion and cushion rubber (Buy by separated)	
13 MUFFLER COMPONENT	
13.1 Dismantled mulffer1.....	68
Dismantled muffler flange	
13.2 Dismantled mulffer 2.....	69
Dismantled muffler component	
13.3 Mulffer component.....	70
Dismantled muffler component	
14 LOWER WIND DEFLECTOR COMPONENT	
14.1 Lower wind deflector component-1.....	71
Dismantled lower wind deflector component	
14.2 Lower wind deflector component-2.....	72
Dismantled lower wind deflector component	

All the information, illustrations and photographs collected in this manual are compiled according to the latest products. However, there may be some inconsistencies between your motorcycle and this manual due to the continuous improvement of the product and other changes.

©Guangdong Tayo Motorcycle Technolog Co.
Ltd All rights reserve

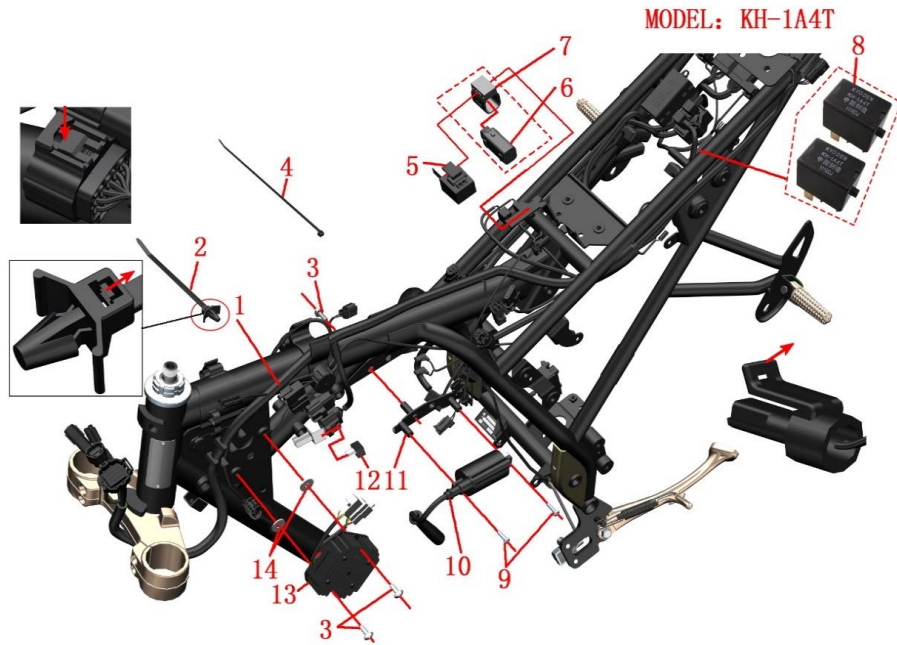

PROCEDURE:

●Main harness

Different plug-in methods are different, please unplug all the electrical components connected to the main thread according to the actual operation. It needs to use a word screwdriver, forceps, scissors and other tools to assist. The binding (2)、(4) can be picked out by using scissors. It is recommended to cut the strap directly with scissors and replace the material with the same specifications on the official website.

●Flasher and dump switch

Remove the rubber sleeve (7) that connects the flasher (5) to the mounting bracket on the frame, and remove the dump switch with the same method, then separate the dump switch (6).

●Relay&head light diode

Pull out the electric injection relay (8) and the large lamp diode (12) directly.

●Ignition coil &support

Remove the crosshead bolts (9) with a cross screwdriver and remove the ignition coil. Remove the bolt (3) with 10# sleeve and remove the ignition coil support (11).

●Rectifier

Remove the bolts (3) with the inner hexagon tool and remove the rectifier (13),then remove the asbestos pad (14).

FIG.1 FRAME&ELECTRONIC PARTS COMPONENT		Electronic parts COMPONENT-1	CHK	CAUTION
			ADJ	
NO.	PART NO.	PART NAME	QTY	
1	1184100-097000	Wire Harness Assembly	1	
2	1224100-030000	Bolt binding	1	
3	1251100-102000	Non-standard bolt M6×16 (304 stainless steel)	3	
4	1226000-218000	Grade 0 flame retardant tie (black 3.6×295)(5 pcs/after sale)	8	
5	1184200-039000	ZT310—R Flasher	1	
6	1184100-002000	ZT250—S Dump switch	1	
7	1244100-082000	ZT250—S Dump switch gum cover	1	
8	1186001-018000	ZT250-S Four-pin Normally Open Relay(after-sale)	2	
9	1250201-032093	GB818M5×16 z (color zinc)	2	
10		ZT250—R Ignition coil, ignition cable component	1	
		ZT310 EFI Ignition coil		
11	1274100-085000	ZT250—R Ignition coil installing support	1	
12	1184100-101000	ZT250—R Head light diode	1	
13	1184100-015000	ZT250—S Rectifier	1	
14	1270301-023000	Stainless steel heat insulation mat 6×20×1.6(5 pcs/after sale)	2	

CAUTION:

● All standard parts must meet the standard torque value when reassembling, and refill the engine oil according to the operation instruction.

● The "ZT250 EFI Ignition coil" and the "ZT310 EFI Ignition coil" cannot be universal.

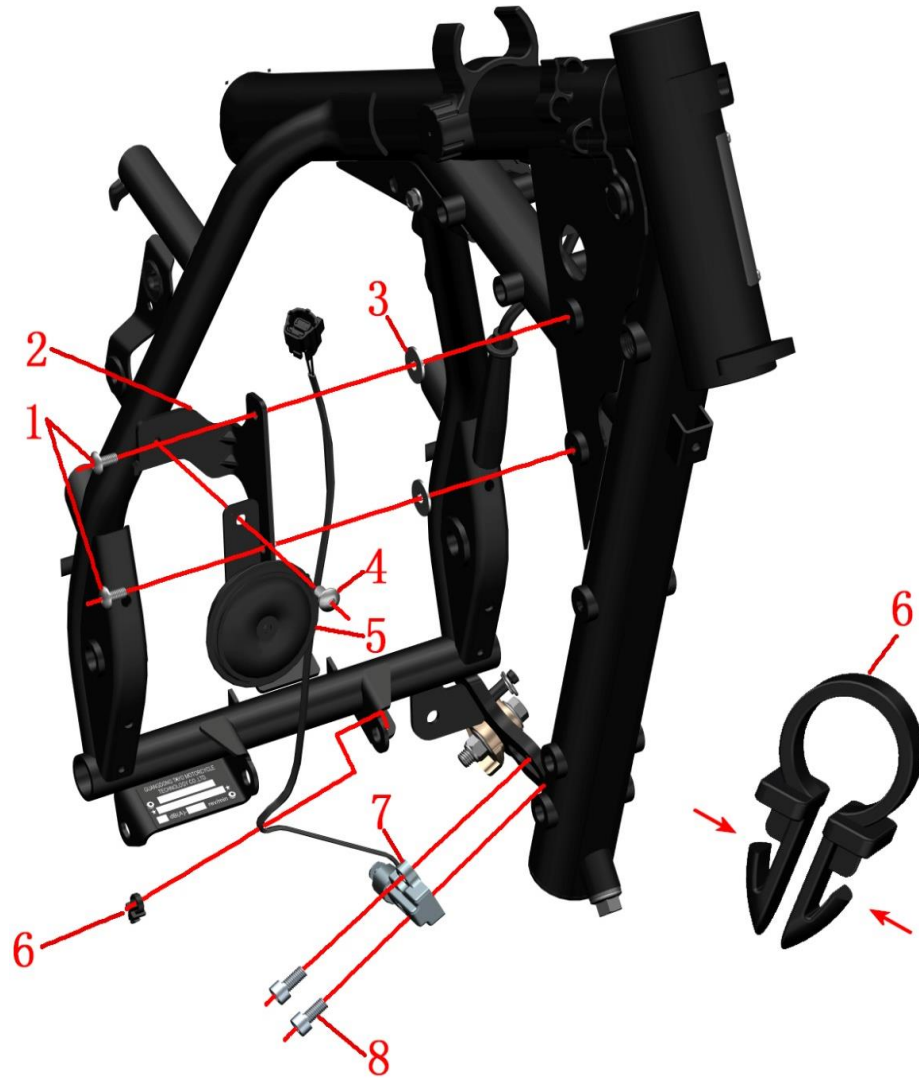

FIG.2 FRAME&ELECTRONIC PARTS COMPONENT		Electronic parts COMPONENT-2	CHK	CAUTION
			ADJ	
NO.	PART NO.	PART NAME	QTY	
1	1251100-102000	Non-standard bolt M6×16 (304 stainless steel)	2	
2	1274100-086000	ZT250—R Horn intalling support	1	
3	1270301-023000	Stainless steel heat insulation mat 6×20×1.6(3mm/after sale)	2	
4	1251100-101000	Non-standard bolt M6×16 (304 stainless steel)	1	
5	1184200-004000	ZT310 Horn	1	
6	1274100-017000	ZT250—S Cable clip	1	
7	1184100-012000	ZT250—S Flameout switch	1	
8	1250205-040095	GB70.1 Hexagon socket screw M8×16(color zinc)	2	

PROCEDURE:

●Horn and support

Remove the bolts with the inner hexagon tool (4) and remove the horn (5). Remove the bolt (1), the horn support (2) and the asbestos pad (3).

●Flameout switch

Use pliers (as above picture shown) to hold the line in the direction of the arrow with a slightly clamping hand to remove the cable clip (6). Remove the bolts (8) with the inner hexagon tool and remove the flameout switch (7).

CAUTION:

- Please pay attention to the strength when removing the cable clip.
- An asbestos pad is needed to insulate the heat transfer between horn support and frame.



FIG.3 FRAME&ELECTRONIC PARTS COMPONENT		Frame plastic parts	CHK	CAUTION
NO.	PART NO.		ADJ	
		PART NAME	QTY	
1	1274100-002000	ZT250—S Cable clamp	2	
2	1224100-049000	ZT250—R Cable collection clip	1	
3	1244100-019000	ZT250—S Inner fuel tank fix glue cushion	1	
4	1244100-138000	ZT250-S Side cover round rubber(5 pcs/after-sale)	8	
5	1244100-061000	ZT250 Frame water proof rubber plug	2	
6	1240100-023000	Battery positive protection glue.	2	

PROCEDURE:

● Cable collection clip

First, take the cable and the main thread out from the collection clip, then use the straight screwdriver to pick up the middle part of the cable clip. Then take cable collection clip (2) off.

● Inner fuel tank fix glue cushion

Use both hands to hold the two ends cylinder parts of the inner fuel tank limited glue cushion (3) and should push it out.

● Side cover cushion

Remove the side cover cushion (4) with your hand directly.

● Frame waterproof rubber plug

Remove the frame waterproof rubber plug (5) with your hand directly.

● Positive pole protection glue

Find out the slot parts position, open and take it out with tools.

CAUTION:

● It must be dismantled them first, such as the cushion, fuel tank cover, inner fuel tank, sider cover, tail dress and so on.

● All parts should be correctly assembled.

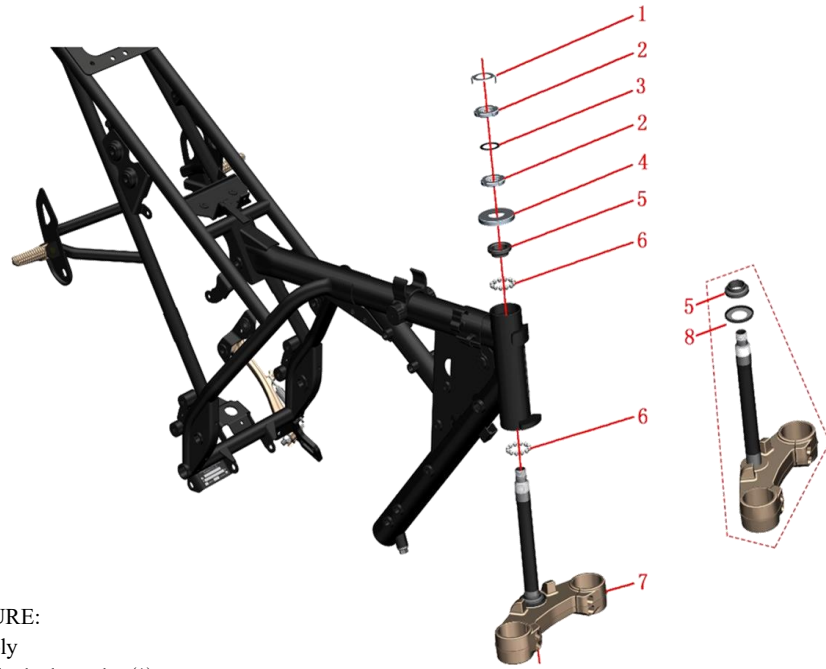
**PROCEDURE:**● **Disassembly**

- Remove the lock washer(1).
- Remove the top adjusting nut (2) by using a hook wrench tools.
- Remove the rubber pad (3).
- With one hand to hold down the down connected plate assembly (7), the other hand use a special four-jaw set or hook wrench to remove the adjusting nut(2).
- Remove the upper dustproof cover(4).
- Remove the down connected plate component(7).
- Remove the axletree ring (5) of the upper riser and the steel ball(6).
- Remove the steel ball of the down connected plate component(7).

● **Assemble**

- When reassembling, the conjoined steel beads should be painted lubricating grease,attention to the dosage.
- The torque of rating nut which closes to upper dustproof cover is required to about 14N.m.so as to be able to rotate out of nimbleness.
- The top adjusting nut only needs to rotate to the bottom of the nut groove alignment, not too tight to prevent the rubber pad (3) from deformation too large.

FIG.4 FRAME&ELECTRONIC PARTS COMPONENT		Steering rack component	CHK	
NO.	PART NO.	PART NAME	ADJ	
1	1134100-040000	ZT250-S Adjusting nut locking washer(5 pcs/after-sale)	1	CAUTION
2	1251300-046093	ZT250—S Steering column rating nut (color zinc)	2	
3	1244100-135000	ZT250-S Adjusting nut rubber gasket (5 pcs/after-sale)	1	
4	1224100-005000	ZT250—S Steering column upper dustproof cover	1	
5	1130900-053000	ZT250-S shaft ring (after-sale)	1	
6	1130900-054000	ZT250-S conjoined steel ball (5 pcs/after-sale)	2	
7	1134100-015000	ZT250—S Down connected plate (selfmade/with steel bowl) COMPONENT	1	
8	1224100-006000	ZT250—S Steering column down dustproof cover	1	【1】

CAUTION:

- Remove the head part component, handlebar component and front shock absorber component first .
- Please pay attentin to fix the awaiting repair motorcycles well during disassembly,prevent dumping by accident.
- Please check whether the steel beads of the conjoined body have abnormal phenomena such as partial abrasion and rust.If YES, please buy the regular accessories on ZONTES official website, if not, please be sure to grease the old grease and repaint the lubricating grease on it.
- It must be to check whether the steel ball is available during reassembly.
- It must be reasonable to adjust the steering, too loose will cause the locomotive to brake slightly, and the locomotive will shake slightly, too tight can lead to inflexibility, resulting in safety hazards.
- If you have the ability and the right tool, you can change the shaft ring (5) and the dustproof cover (8).During the replacement process, pay attention to the protection of the lower connected plate. After replacement, it must be to check the parallelism of the column and the damping hole, the vertical degree of the vertical column and the lower connected plate.
- **【1】** the down connected plate (selfmade/with steel bowl) component(7), has been contains the Steering column down dustproof cover(8).

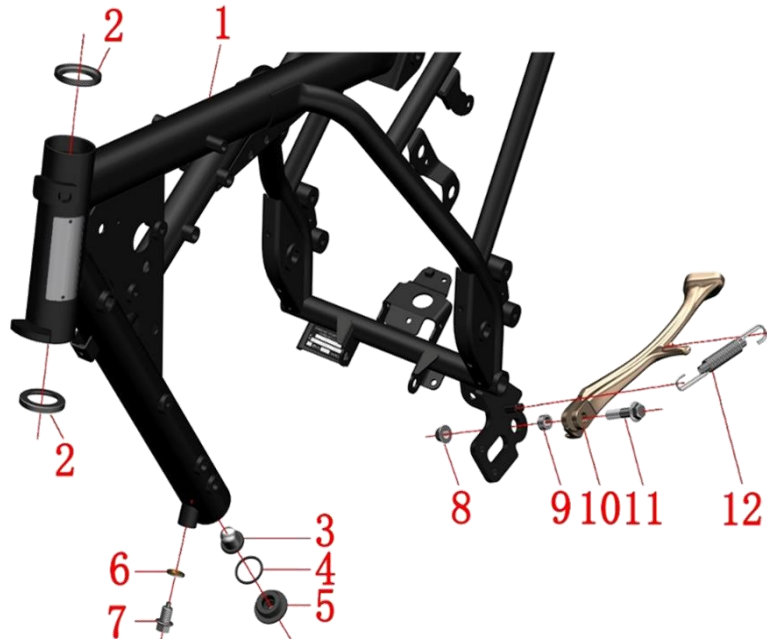

PROCEDURE:

●Checking the cushion loop

Checking whether the cushion loop (2) is frayed, if as it, please replace it on ZONTES website, fix the cushion loop well and paint the lubricating grease on it with appropriate tool.

●Replacing the engine oil filter screen

Put the oil pan on the bottom and use the appropriate tools to remove the oil cold joint (5), O ring (4), and oil filter screen(3). When replacing the oil filter screen (3), the O-ring(4) must be replaced at the same time. The oil cooling joint(5) must be tightened well when re-assembling which meets the standard torque value.

●Release the frame tube enging oil

Put the oil pan at the bottom, use the appropriate tool to remove the oil bolts(7) and the sealing gasket(6), and remove the oil from the frame tube. Refer to the instructions for detailed steps to replace the oil. It is recommended that the engine oil should be replaced with oil bolts (7) and sealing gasket(6) to prevent oil leakage.

●Sider support

Use the cross screwdriver to remove the side support spring, and guard against the personal injury caused by spring contraction, remove the nuts (8) and bolts (11) with the appropriate tools. Remove the side support (10) and bush(12), paint the lubricating grease on the bush when re-assembling ,then put it into the frame(1).

FIG.5 FRAME&ELECTRONIC PARTS COMPONENT		Frame, Side support, the operation of releasing engine oil	CHK ADJ	CAUTION
NO.	PART NO.	PART NAME	QTY	
1	4014100-013000	ZT250—R Frame COMPONENT (ABS/fix loop/nameplates/Europe IV)	1	
2	1130900-052000	ZT250-S upper steel bowl (after-sale)	2	
3	1274100-006000	ZT250—S Frame engine oil filter screen	1	
4	1051453-003000	27.4×2.65 Acrylate O gule cushion loop	1	
5	1274100-024000	ZT250—S Oil cooling joint	1	
6	1244100-033000	Sealing gasketφ12×φ20×2	1	
7	1251100-066093	M12×1.5×15 Ablassschraube (color zinc)	1	24±4N.m
8	1251300-057093	Non-standard bolt M10×1.5 (dacromet)	1	
9	1251700-025091	ZT250—S Side support bush	1	
10	4024100-001000	ZT250—S Side support	1	
11	1251100-088094	Non-standard bol M10×1.5×43 (dacromet)	1	
12	1260300-079093	ZT250-S side stand spring(after-sale)	1	

CAUTION:

- Remove the wind deflector component, handle bar component, steering column component first.
- Paint the lubricating grease on the cushion ring to decrease the rotary resistance of front forklift.
- The waste oil needs to be collected and returned to qualified institutions. It is forbidden to dump and pollute the environment and the source of water.
- Pay attention to safety when mounting side support spring.
- All parts should be correctly assembled.
- If you need to change the material, please buy the genuine article on ZONTES website.
- Frame AASY should press steel bowl well, riveting the name plate, it needs to offer the VIN of original motorcycle.

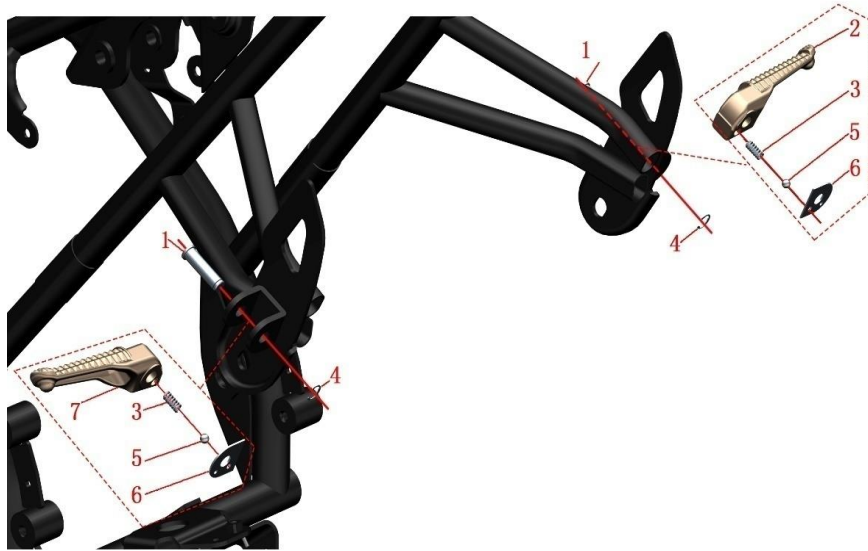

FIG.6 FRAME&ELECTRONIC PARTS COMPONENT		Rear pedal COMPONENT		CHK	CAUTION
				ADJ	
NO.	PART NO.	PART NAME		QTY	
1	1274100-012000	ZT250—S Pedal axis pin		2	
2	1274100-049000	ZT250—R Rear right pedal		1	
3	1264100-005000	ZT250—S Pedal Steel ball spring		2	
4	1264100-006000	ZT250—S Pedal clamp spring		2	
5	1274100-010000	ZT250—S Rear pedal steel ball		2	
6	1274100-052000	ZT250—S Rear pedal locating plate		2	
7	1274100-047000	ZT250—R Rear left pedal		1	

PROCEDURE:● **Disassembly rear pedal**

Pry open the clamp spring (4), then push the pedal pin shaft out with tools. Pull the pedal (2) or (7) outward.

● **Assemble rear pedal**

Place one side with two holes of pedal horizontally and put the pedal spring (3) in the pedal (2) or (7) in the small hole.

Put the steel ball (5) inside, compress the steel ball and spring with the positioning plate.

Assemble the pedal on the frame and distinguish the right, left pedal.

The axis pin (1) is inserted after the pedal hole is aligned with the pedal support mounting hole.

Insert the clamp spring into the pin shaft slot.

CAUTION:

- Take care of the material when removing the pedal.
- There are "L" or "R" sign on the back side of pedal.
- All parts should be correctly assembled.
- If you need to change the material, please buy the genuine article on ZONTES website.

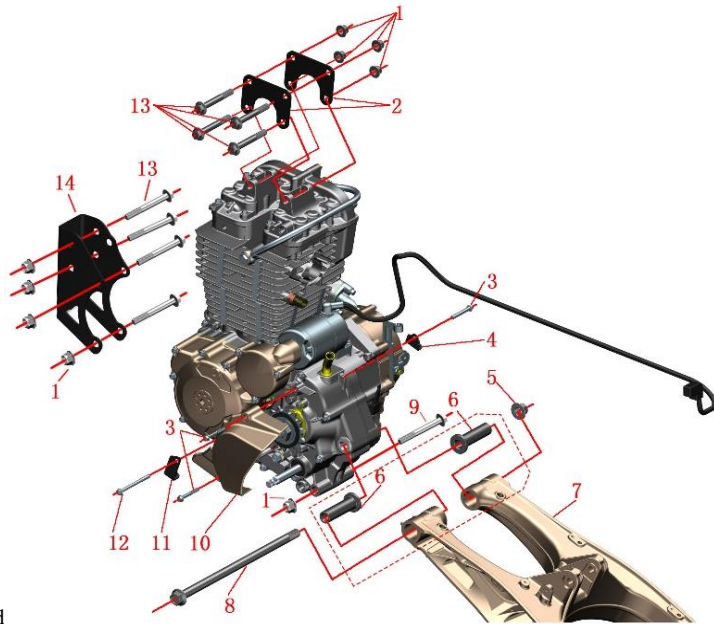
**PROCEDURE:**

● Chain wheel cover

Dismantle the left sid

● Bracket engine hanging

Use the sleeve to cover the head of the bolt (13) then dismantle the nut (1) with the sleeve. Remove the bolt then dismantle the bracket (14).

Use the sleeve to cover the head of the bolt (9), remove the nut (1) with the sleeve, then remove the bolts.

● Hanging piece

Use the sleeve to cover the head of the bolt (13) and remove the nut (1) with the sleeve. Can not remove the bolt (13) and the hanging piece (2).

● Engine middle part, frame and rear forklift component

Use the sleeve to cover the head of the bolt (8) and remove the nut (5) with the sleeve. Other parts cannot be removed.

● Engine

Both persons hold the left and right boxes of the engine. One person takes the bolt (13) and hanging piece (2) off. Remove the rear flat fork ASSY (7). Support the engine to shift to one side, and pay attention to safety during the movement. Put the engine flat on the ground.

● Wind deflector support, rear forklift sleeve

Remove the bolts (3) with the sleeve then remove the left support (11) and right support (4) of the wind deflector.

FIG.1FRAME&ENGINE		FRAME&ENGINE	CHK	CAUTION
NO.	PART NO.	PART NAME	ADJ	
1	1251300-057093	Non-standard nut M10×1.5 (dacromet)	9	
2	1020241-225000	ZT250—R Upper hanging piece	2	out of stock
	1020242-385000	ZT310—V Upper hanging piece		
3	1251112-003093	M6×45 Hexagonal flange face 9.8 level bolt.	3	
4	1274100-033000	ZT250—S Right support of down wind deflector	1	
5	1251300-059093	125 Spindle nut of rear forklift M14×1.5 (dacromet)	1	
6	1274100-009000	ZT250—S The axle sleeve of rear forklift	2	
7	4024100-024000	ZT250 Aluminum alloy rear forklift ASSY (with axletree/ oil seal)	1	
8	1252200-016093	250 Rear forklift axle Ø14×310 (dacromet)	1	
9	1251100-086093	Non-standard bolts M10×1.5×112 (dacromet)	1	
10	4044100-022051	ZT173YMM Output chain wheel cover	1	
11	1274100-034000	ZT250—S Lower wind deflector left support	1	
12	1251112-005093	M6×75 Hexagonal flange face 9.8 level bol	1	
13	1251100-132003	Non-standard bolts M10×1.5×80 (dacromet)	8	
14	4024100-031000	ZT250—R Bracket	1	

CAUTION:

● It is necessary to remove the seat cushion, fuel tank, side cover, pedal support, wind deflector, shift lever, muffler, radiator and pipe, cable, air filter joint, chain, engine start motor positive line pole, etc.

● Use appropriate tools to support the motorcycle to prevent motorcycle dumping during disassembly. Single operation is forbidden.

● The waste oil needs to be collected and returned to qualified institutions. It is forbidden to dump and pollute the environment and the source of water.

● Please pay attention to safety to prevent accident.

● It must be operated the engine with more than one people at the same time when removing the engine.

● All standard parts must meet the standard torque value when reassembling, and refill the engine oil according to the operation instruction.

● The "1020241-225000 ZT250—R Upper hanging piece" out of stock, it can replace by "1020242-385000 ZT310—V Upper hanging piece".



ZT250—R Upper hanging piece

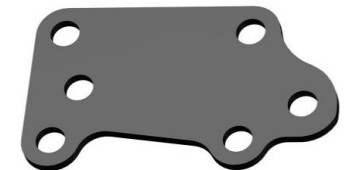

ZT310—V Upper hanging piece

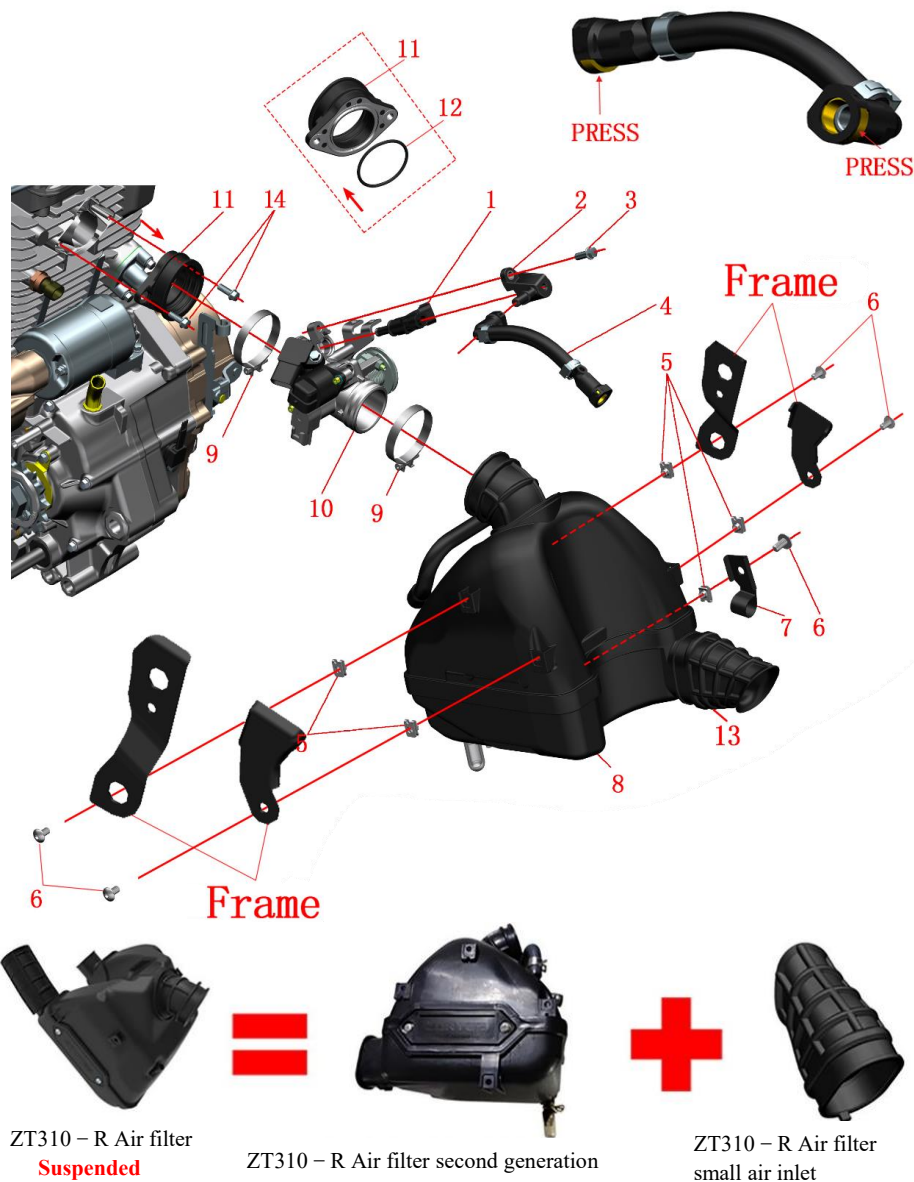

FIG.1 INDUCTION SYSTEM COMPONENT		Induction system component	CHK	CAUTION
NO.	PART NO.	PART NAME	ADJ	
1	1050954-007000	39-N008 Fuel injector	1	
2	1050954-008000	39-N008 Fuel injector fixator	3	
3	1251112-001093	M6×16 Hexagon flange bolt (color zinc)	1	
4	1251300-063093	ZT250-R Fuel injector high pressure oil pipe unit	5	
5	1251100-101000	Plywood M6×11×15 (color zinc)	5	
6	1274100-076000	Non-standard bolts M6×12 (304stainless steel)	5	
7	1224200-001000	ZT250-R Rear disc brake pipe clamp (steel)	1	
8	1051354-004000	ZT310-R Air filter	1	Suspended
	1224200-058000	ZT310-R Air filter second generation		
9	1050953-024000	Φ56×10 Pipe clamp units	2	
10	1050954-007000	TB35 Throttle body parts (DB34B)	1	
11	1050953-022000	TB35 Induction-tube units	1	
12	1051453-007000	45×2.1 Fluoroelastomer O-ring	1	
13	1244100-083000	ZT310-R Air filter small air inlet	1	
14	1251100-061093	M6×22 Hexagon flange bolt (color zinc)	2	

PROCEDURE:

●High pressure oil pipe

Press anti-loose ring on the joint of the fuel pump joint which is close to high pressure oil pipe (4), then pull it out directly, the balance fuel in the tube needs to be connected to the oil pot. Please prevent fuel dripping onto any part of the vehicle. Press the anti-loose card ring near the injector fixator(2) to unplug the high-pressure oil pipe, as picture shown, smoking and lighting fires are strictly forbidden during disassembly.

●Air filter

Remove the bolts (6) with the inner hex sockets tool, pull the the tubing clip(7)out from the disc brake pipe and take it out. Loosen the pipe hoop assembly on the air filter (8), clamp on the exhaust pipe and unplug the exhaust pipe from the exhaust outlet of the engine. Then use the rubber plug to prevent the foreign body from entering the damaged engine. Remove the air filter (8) and plywood nut (5).Remove the small air inlet(13) from air filter(8).

●Throttle valve component

Remove the bolts (14) with the club wrench and remove the throttle valve assembly. Loosen and remove the pipe band (9) between the induction manifold assembly (11) and the throttle part (10),Remove the O ring (12) from the induction pipe assembly.Remove the screw (3) of the fuel injector fixator (2) with the sleeve and remove the fixer and the fuel injector (1).

CAUTION:

- Fireworks, phone calls or phone calls should be strictly prohibited near the demolition site to prevent accidents.
- The "ZT310-R Air filter" has been suspended. It should be replaced by"1224200-058000 ZT310-R Air filter second generation + 1244100-083000 ZT310-R Air filter small air inlet".

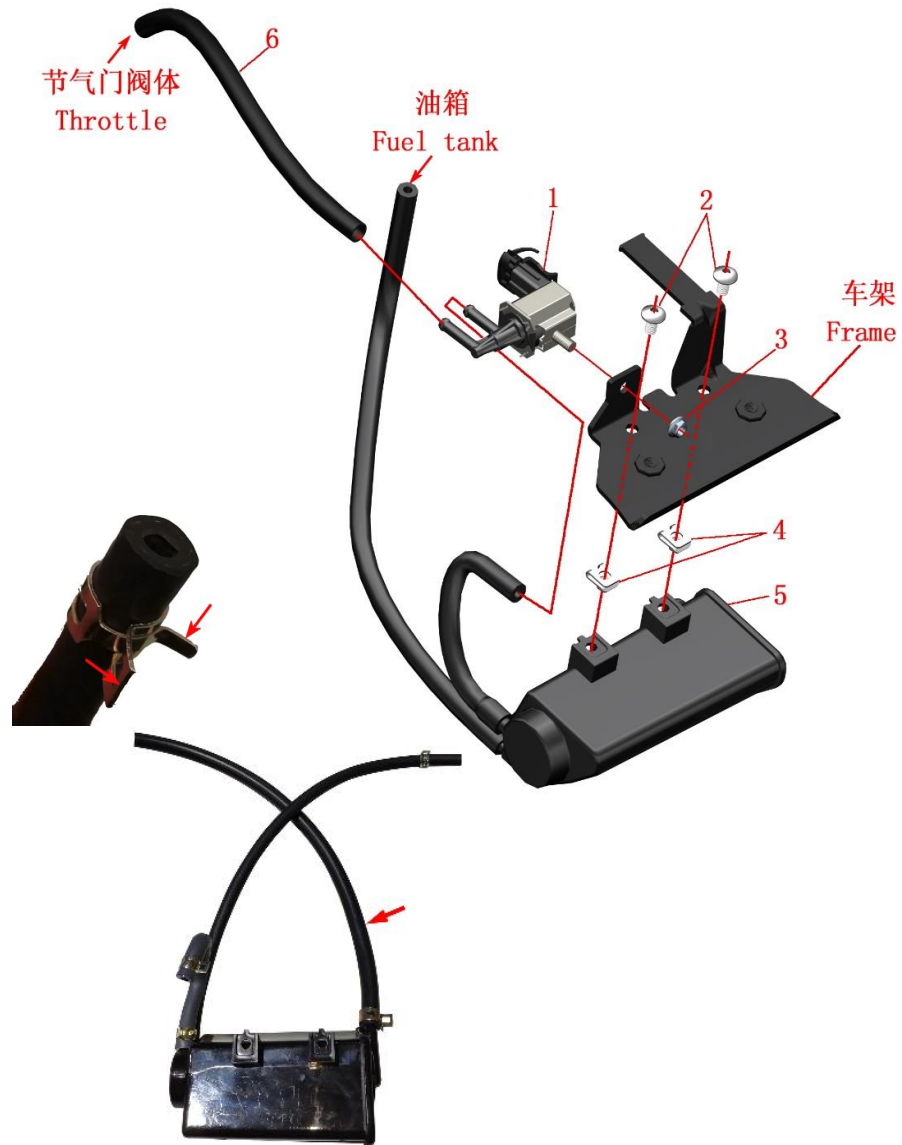

FIG.2 INDUCTION SYSTEM COMPONENT		Carbon Tank component	CHK	CAUTION
			ADJ	
NO.	PART NO.	PART NAME	QTY	
1	1050954-009000	YH Carbon tank electromagnetic valve	1	
2	1251100-101000	Non-standard bolts M6×12 (304 stainless steel)	2	
3	1250303-040093	GB6177.1M6 (environmental color)(5 pcs/after-sale)	1	
4	1251300-063093	Plywoord M6×11×15 (color zinc)	2	
5	1224200-158000	ZT310-R Carbon tank II (with fuel pipe)	1	
6	1244200-004000	TB41 Throttle valve desorption rubber tubing	1	

PROCEDURE:

● Carbon tank

Clamp the pipe clamp on the exit of the oil and gas separator at the bottom of the tank with pliers and pull out the tubing. Unplug carbon tank solenoid valve (1) with the same method. Remove the bolts with the inner hex tool (2). Remove the carbon tank (5) from the left side of the frame and remove the plywood nut (4).

● Desorption tubing

Clamp the pipe clamp on both ends of the desorption tubing, and take it (6) out.

● Carbon tank electromagnetic valve

Remove the plug of the solenoid valve (1), then remove the nut (3) with the sleeve and remove the electromagnetic valve.

CAUTION:

- It needs to remove the seat cushion, side cover, oil tank cover, bladder and so on.
- Regularly check whether the filter element of the carbon tank and air filter is not ventilated, otherwise it may cause the oil supply to affect the driving experience.
- It should be no crimp, entanglement and other phenomena.
- Add a fuel pipe on March 13, 2019 to prevent fuel dropping onto the muffler surface.

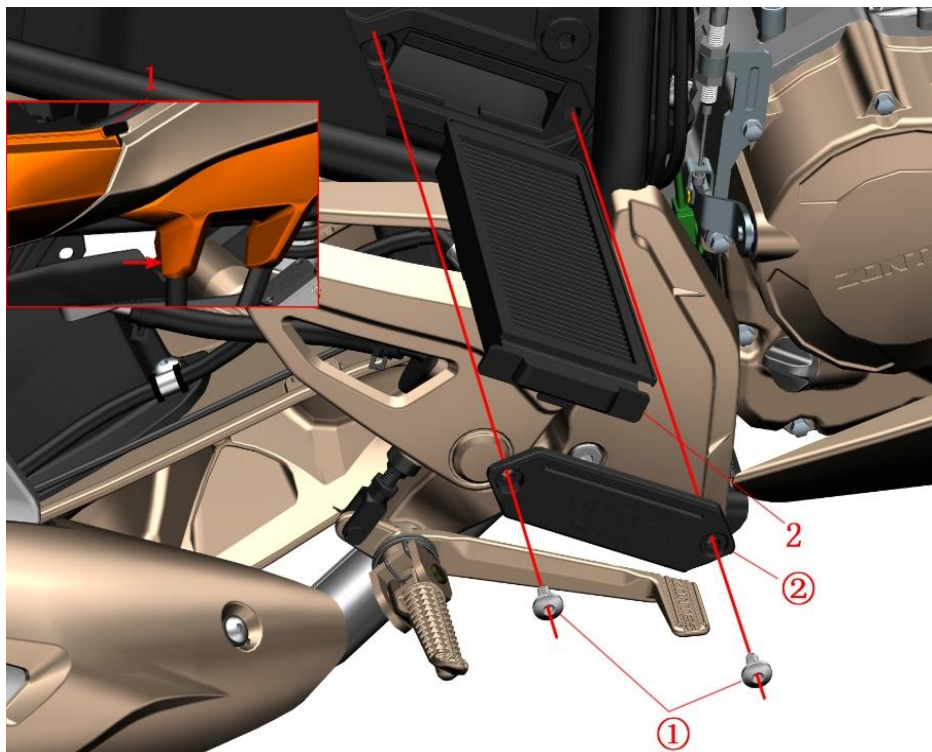

ZT250-R Air filter sponge filter element



ZT310 Air filter sponge filter element (with packaging)

FIG.3 INDUCTION SYSTEM COMPONENT		Replace the air filter element	CHK	
			ADJ	
NO.	PART NO.	PART NAME	QTY	CAUTION
1	1224100-024000	ZT250—S Plastic connector block	1	
2	1224100-055000	ZT250-R Air filter sponge filter element	1	
	1226400-174000	ZT310—R air filter element (with carton packaging)		

PROCEDURE:

● Filter element

If you need to maintain the filter element of the air filter, remove the plastic connection piece (1). Press the a-end of the right side cover to pull out forcibly, then pull out the b-end, remove the right cover assembly; Similarly remove the left cover assembly. Take the two standard parts ① out of air filter with the tool, dismantle the box cover ②, then extract the filter element (2). Blow the dust off the filter core by blowing dust gun in the filter element. If the blowback causes the dust to be unable to clean up, the engine will be damaged or the induction resistance will become larger and affect the driving experience. If there is any damage, please log on the official website and purchase another parts.

CAUTION:

- Regularly check whether the filter element of the carbon tank and air filter is not ventilated, otherwise it may cause the oil supply to affect the driving experience.
- When blowing dust, pay attention to maintain a certain distance to avoid excessive damage to the filter element.
- The ZT250-R air filter sponge filter matches the ZT310-R air filter. ZT310-R air filter element (with packaging) matches ZT310-R air filter second generation. It's possible to observe whether the left side of the air filter has convex, if has it's ZT310-R air filter. Or observe the right air intake such as the air intake has a significant shrinkage of the zT310-R air filter second generation, no significant change is the ZT310-R air filter. Note to distinguish the corresponding air filter and then order to purchase the filter element, or by removing the filter to observe that the material is sponge or paper to distinguish.



ZT310—R Air filter

ZT310—R Air filter second generation

ZT310—R Air filter small air inlet

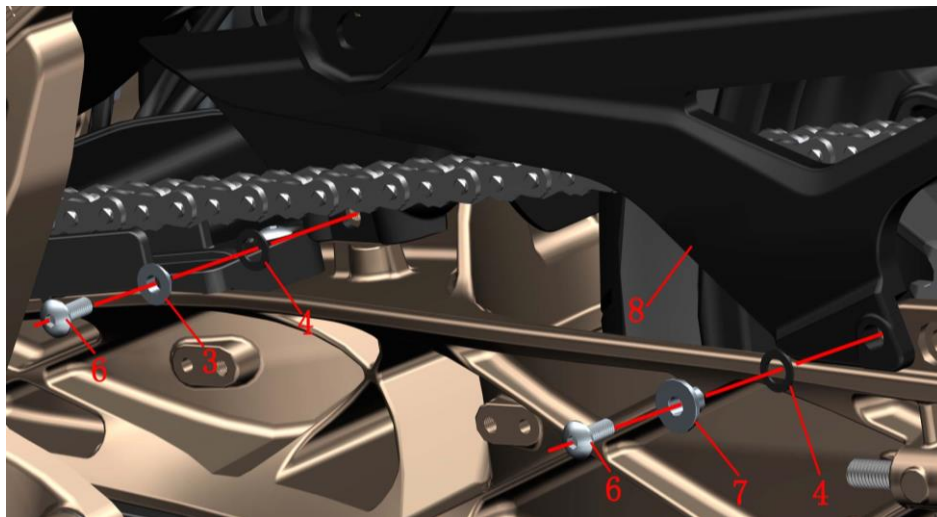
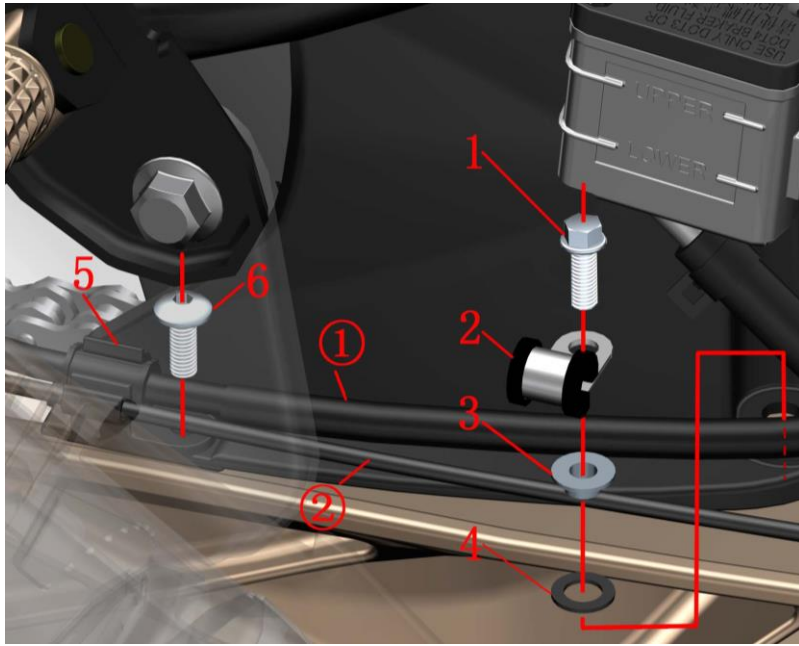

FIG.1 REAR FORKLIFT COMPONENT		Rear inner mudguard	CHK	⚠
			ADJ	
NO.	PART NO.	PART NAME	QTY	CAUTION
1	1251112-001093	M6×16 Hexagon flange bolt (color zinc)	1	
2	1274100-088000	ZT250-R Rear disk brake oil pipe clamp (steel piece/with rubber gasket)	1	
3	1274100-155095	Flanged bushing φ6.2×φ8.4×3.5+φ14×1.5(5 pcs/after-	2	
4	1241200-124021	flanging bushing buffer rubber (φ8.5×φ14×1)(5 pcs/af	3	
5	1224200-003000	ZT310-Z Rear disk brake oil pipe clamp	1	
6	1251100-102000	Non-standard bolts M6X16 (stainless steel)	3	
7	1251700-059093	Reverse bush φ6.4×φ9×8+φ18×2 (environmental color)	1	
8	1224200-002000	ZT310-Z Inner fender	1	

PROCEDURE:

●REAR INNER FENDER

First, the brake pipe ① on the right side of the inner clay plate and the wheel speed sensor line ② are removed from the rear disc brake pipe clamp (5). Remove the bolt (1) with the sleeve, and remove 3pcs bolts(6) with the inner hexagon tool, remove the rear disc brake pipe clamp (steel parts/gluing pad) (2), and the rear disc brake pipe clamp (5), turn over the bush (3) and bush(7), and turn over the liner. Buffer glue (4); remove the inner fender (8).

CAUTION:

- Use appropriate tools to support the motorcycle to prevent motorcycle incline during disassembly. No single operation.
- Stay alert throughout the process to prevent accidents.
- All standard parts must meet the standard torque value when reloading.

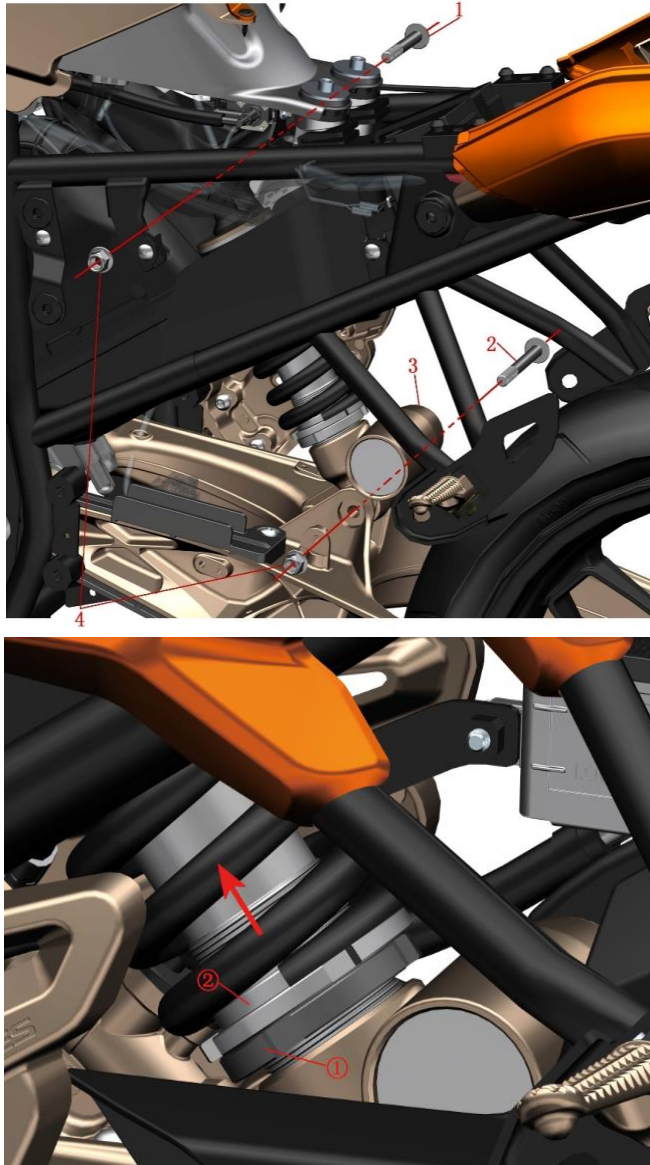



FIG.2 REAR FORKLIFT COMPONENT		Rear shock absorber	CHK	
			ADJ	
NO.	PART NO.	PART NAME	QTY	CAUTION
1	1251100-132003	Non-standard bolts M10×1.5×80	1	
2	1251100-060000	Non-standard bolts M10×1.5×90	1	
3	1114200-001000	Rear shock absorber	1	
4	1251300-057093	Non-standard bolts M10X1.5	2	

PROCEDURE:

●Rear shock absorber

The whole motorcycle level is supported, and the sleeve is used to hold the bolt and the head of the unit respectively. Meanwhile, the bolt is removed with the sleeve, and then the shock absorber is removed along the axial direction of the shock absorber.

●Adjust the softness of the shock absorber

Use the hook wrench to loosen the nut, adjust the nut, adjust the direction of the arrow to the arrow, reduce the shock and soften the shock, and vice versa. Adjust the adjusting nut to fit properly. It is suggested that reasonable adjustment, too soft or hard influence driving experience.

CAUTION:

- Need to remove seat, side cover, rear fender, etc.
- Use appropriate tools to support the motorcycle to prevent motorcycle incline during disassembly. No single operation.
- Stay alert throughout the process to prevent accidents.
- All standard parts must meet the standard torque value when reloading.
- After shock absorption soft and hard factory has been transferred to the practical position.

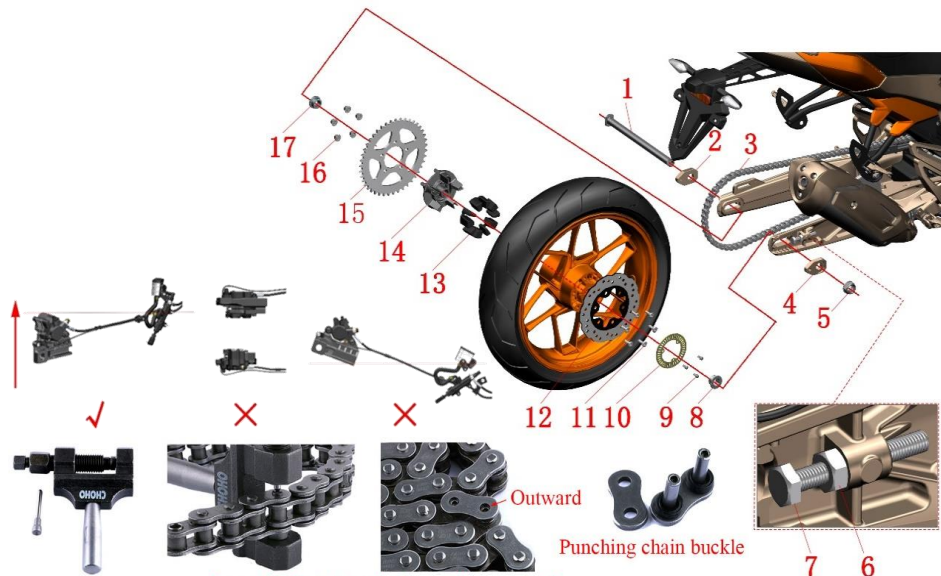

A special chain installation tool is required.
This chain does not contain tools and must be purchased separately.

PROCEDURE:

●Rear wheel assembly

Disassemble rear wheel axle nut(5)with socket sleeve.

Use open spanner to move chain adjuster nut (6)on both sides towards rear wheel axle until they reach chain adjusting bolt (7).Then rotate the bolt and nut towards motorcycle front direction till the end. ◦

Push rear wheel assembly towards motorcycle front direction and take off the chain(3)from sprocket(15).

Tie firmly the rear disc brake clamp and avoid it to be lifted higher than disc brake oil cup. Hold the rear wheel assembly. Punch rear wheel axle(6) with rubber hammer. Take off right chain adjuster(3), rear tire and rim assembly, left chain adjuster(5),the rear wheel axle(6).Disassemble the right axle sleeve(7), left axle sleeve(12) at last.

●Brake disc, ABS ring

Remove the bolts(9)with the sleeve,and remove the ABS(10).Remove the bolts (11)with the inner hex tool and remove the brake disc(12).

●Chain wheel seat, chain wheel

Separate the sprocket and sprocket components from the tire and rim components and remove the sprocket(15)after the nut (16) is removed with the sleeve.

●Buffering rubber

Use a screwdriver to remove the buffer from the rim assembly and take care to prevent damage when disassembling

FIG.3 REAR FORKLIFT COMPONENT		Rear tire module	CHK	CAUTION
NO.	PART NO.		PART NAME	
1	1094100-032000	ZT250-R Rear wheel hollow shaft	1	
2	1032142-072035	Left adjuster (Titanium)	1	
3	1080200-032000	114 Section chain	1	【1】
	1080200-055000	114 Section chain (Open type)		
4	1032142-073035	Right adjuster(Titanium)	1	
5	1251300-067000	Rear wheel hollow shaft nut	1	110N.m
6	1251300-050000	Adjuster nut M10 (304 stainless steel)	2	
7	1251100-105000	Adjuster bolts M10X70 (304 stainless steel)	2	
8	1274200-002000	Rear wheel right shaft sleeve φ20×φ28×φ38×18.5	1	
9	1250104-006097	GB16674M6×12 (chroming/HH)	3	
10	1274100-054000	ABS9 Anti-lock system gear ring	1	
11	1251100-117093	Non-standard inner hexagonal bolt M8X25	6	
12	1104100-002000	Rear disk brake plate (200X4.5)	1	
13	1240100-210000	KD250-F Chain wheel buffering rubber	5	
14	1094100-029000	Chain wheel seat	1	
15	1080100-034000	Chain wheel	1	
16	1251300-057093	Non-standard bolts M10X1.5	5	
17	1094100-035000	ZT310 Rear wheel left shaft sleeve φ20×φ30×φ35×17.8	1	

CAUTION:

- Use appropriate tools to support the motorcycle to prevent motorcycle incline during disassembly. No single operation.
- Stay alert throughout the process to prevent accidents.
- It is forbidden to use the hammer to tap the hollow shaft thread part of the rear wheel, the disc brake caliper assembly, etc.
- After removing the rear wheel assembly, the rear disc brake calipers are strictly prohibited to be higher than the disc brake oil cup, otherwise the brake will become soft or invalid due to the air entering the pipe. Because the brake pipe has a high vacuum requirement. It is necessary to ensure that there is sufficient capacity to repair and disassembl.
- All standard parts must meet the standard torque value when reloading.
- 【1】 The original car is equipped with a chain without an opening, and the open type is convenient for after-sales replacement of the chain. A special chain installation tool is required. This chain does not contain tools and must be purchased separately.

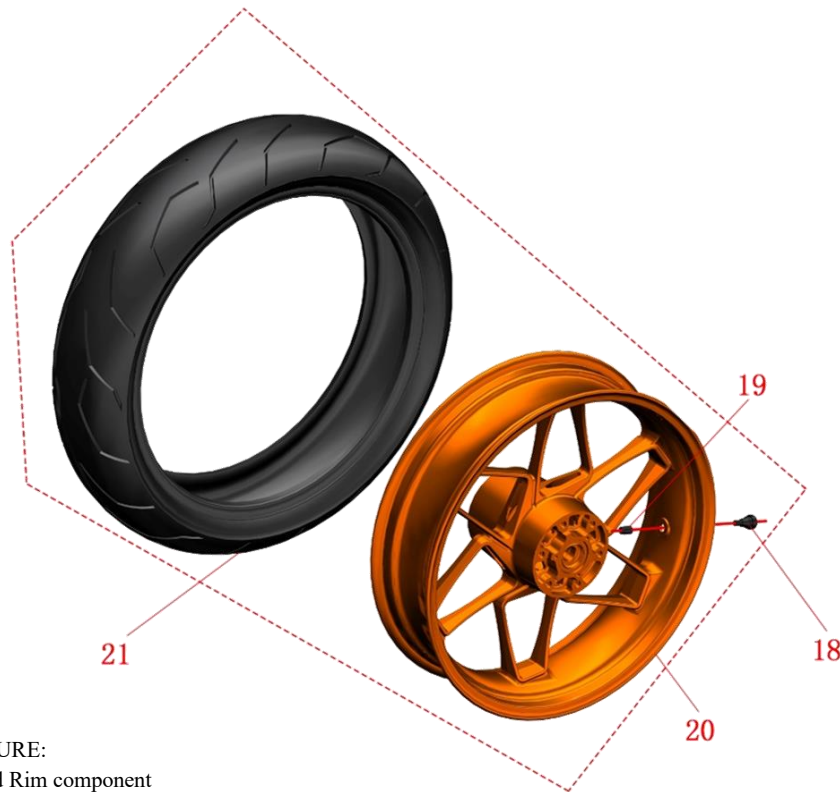

FIG.4 REAR FORKLIFT COMPONENT		Rear rim component	CHK	
			ADJ	
NO.	PART NO.	PART NAME	QTY	CAUTION
18	1230100-047000	Environmental color vacuum tire mouth	1	
19	1230200-006000	Tire valve cap	1	
20	1094100-041000	Bright orange rear wheel rim	1	orange
	1094100-047000	Bright green rear wheel rim		green
	1094100-045000	Bright blue rear wheel rim		blue
	1094100-043000	Rear wheel rim		black
21	1230100-207000	Tire	1	250kPa

PROCEDURE:

●Tire and Rim component

Remove the valve cap and use the tool to release the gas and then remove the rear tyre (21) with a professional tire extractor. Finally, use the appropriate tool to remove the valve.

●Maintainence

Chain and sprocket: refer to the relevant instructions of the chain and sprocket. If you need to replace the chain, please refer to the frame Remove the relevant contents of the engine assembly and remove the flat fork. Refer to the contents of the manual to check and maintain.

Tire: should check regularly whether there are cracks, cracks, pressure and so on. If worn to tread wear mark must replace the same type of tire. Refer to the instructions in detail.

Rim: check the rim for deformation, cracks and other undesirable phenomena. Rotate the rim horizontally to check if there is the situation of stop and shaking.

Wheel shaft: check whether there is deformation or bending with a percentage.

brake plate: the thickness should not be less than 4mm, or it has to be changed.

CAUTION:

●Be careful when removing tires and rims to prevent damage.

●If you need to change the material, please log on the website and buy the genuine article.

●After replacing the tire, check for air leakage and balance.

●Defective tire repair may corrode the rim and cause safety hazards.

●Tire pressure may cause abnormal wear; There is a risk of excessive tire pressure in summer.

●Check the tightness of the chain regularly and suggest to clean the chain once every 1500km. The chain relaxation should be suitable, too large and easy to be out of the chain to cause accidents or serious damage to the engine, too small to aggravate wear and shorten the chain life.

●After replacing the brake disc, it should be about 300 km to be fully integrated to achieve the best braking effect. Adequate braking distance should be set aside during grinding.

●Orange use for orange vehicle; green use for bright green vehicle; blue use for bright blue vehicle; black use for dark blue vehicle.

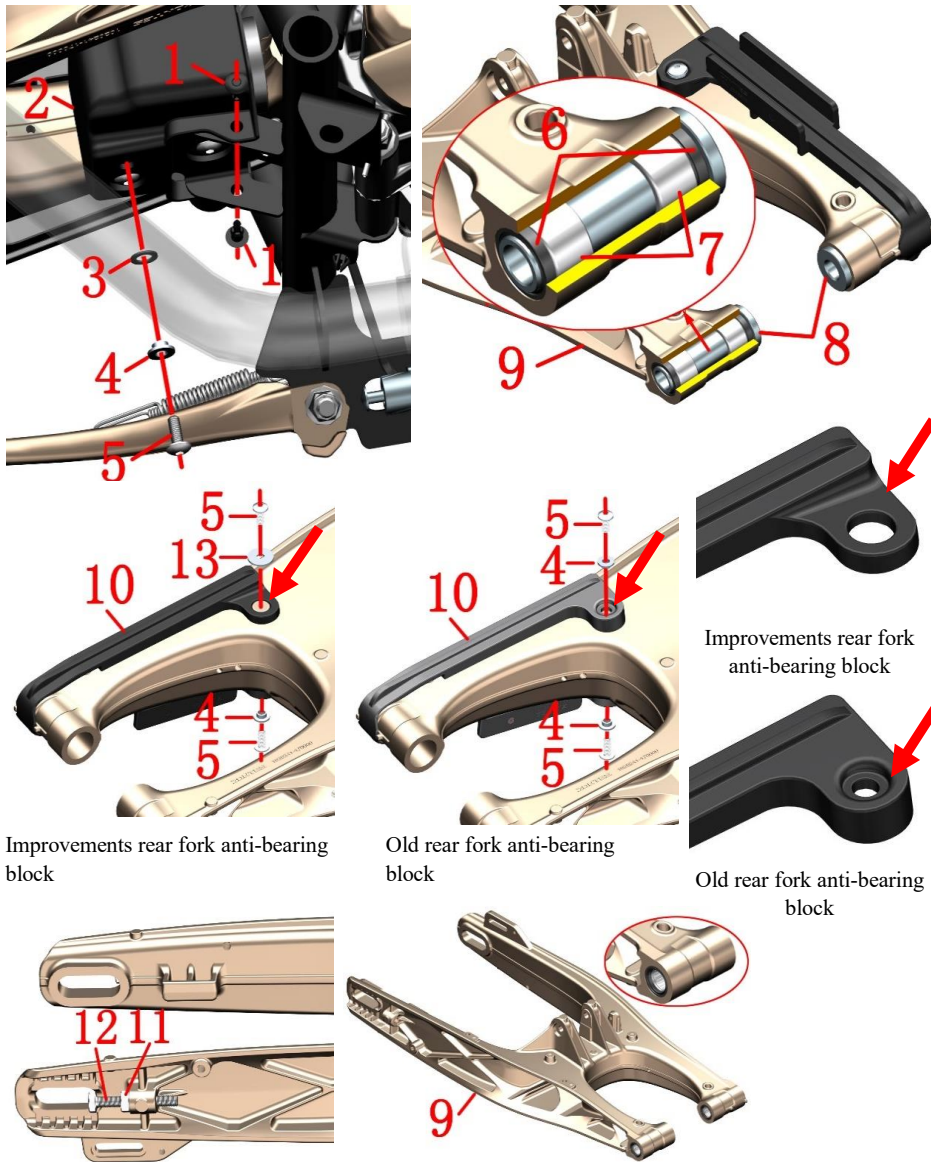

FIG.5 REAR FORKLIFT COMPONENT		Rear forklift component	CHK	CAUTION
NO.	PART NO.	PART NAME	ADJ	
1	1224100-089000	ZT250-S Expansion nail(5 pcs/after-sale)	2	
2	1224100-047000	ABS liquid control unit protection cover	1	
3	1241200-124021	flanging bushing buffer rubber (φ8.5×φ14×1)(5 pcs/af	1	
4	1274100-155095	Flanged bushing φ6.2×φ8.4×3.5+φ14×1.5(5 pcs/after-	3	
5	1251100-102000	Non-standard bolts M6×16 (304 stainless steel)	3	
6	1104100-005000	Oil sealing	4	【1】
7	1094100-001000	Needle bearing	4	
8	1274100-009000	Rear fork shaft sleeve	2	
9	4024100-024000	Aluminum alloy rear fork assembly (with bearing/oil sealing)	1	
10	1244100-066000	Rear fork anti-bearing block	1	
11	1251300-050000	Adjuster nut M10 (304 stainless steel)	2	
12	1251100-105000	Adjuster bolts M10×70 (304 stainless steel)	2	
13	1251500-097000	Non-standard flat mats φ6.5×φ22×1.5 (environmental color)	1	

PROCEDURE:

●ABS liquid control unit protection cover

Press the center part of the expansion nail (1) with the small cross screwdriver to remove the expansion nail. Remove the bolts (5) with the inner hexagon tool, remove the flanging bushing (4) and glue cushion (3), and finally remove the protective cover of ABS liquid control unit (2).

●Rear fork parts

Remove the rear flat fork shaft, rear shock absorption, rear inner mud board, rear wheel assembly, muffler, etc. Remove the bolts(5) with the inner hexagon tool, turn over the flange (4), and remove the grinding block (10).

Remove the screw of the switch (12) and the nut(11) by using the open spanner.

Put the rear flat fork sleeve (8) to the inner top, then remove.

Oil seal (6), needle roller bearing (7) is used for overloading, please ensure the ability to disassemble and decompose.

CAUTION:

●Be sure to fix up the motorcycle in the process of disassembly.

●【1】 For individual sales, the Aluminum alloy rear fork assembly(9) has been contains.

●If your motorcycle manufactured before Set.2,2019,it's need to be accompanied by the purchase of non-standard flat mats(13) when replace Rear fork anti-bearing block (10).

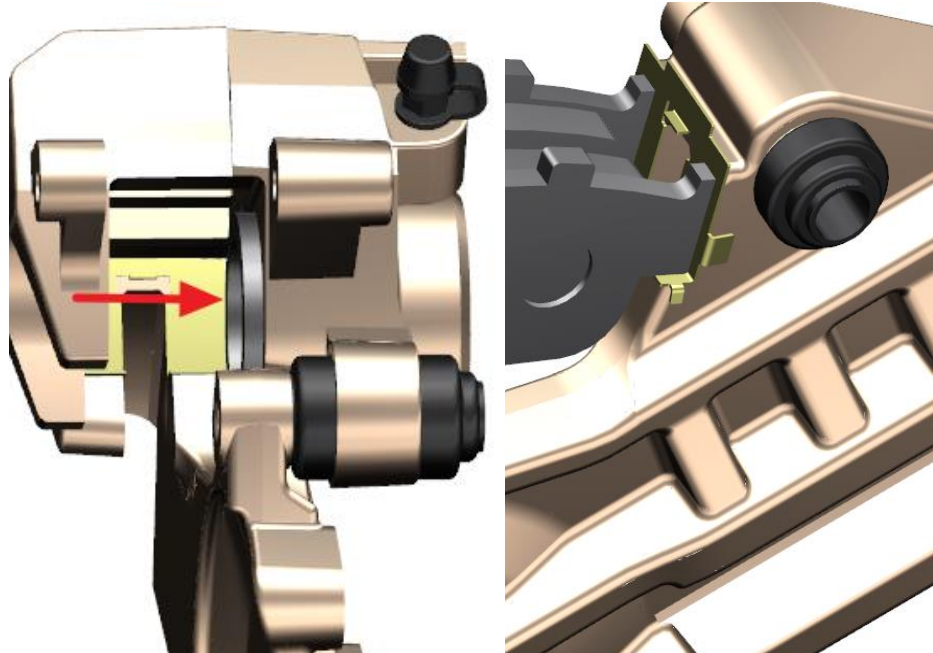
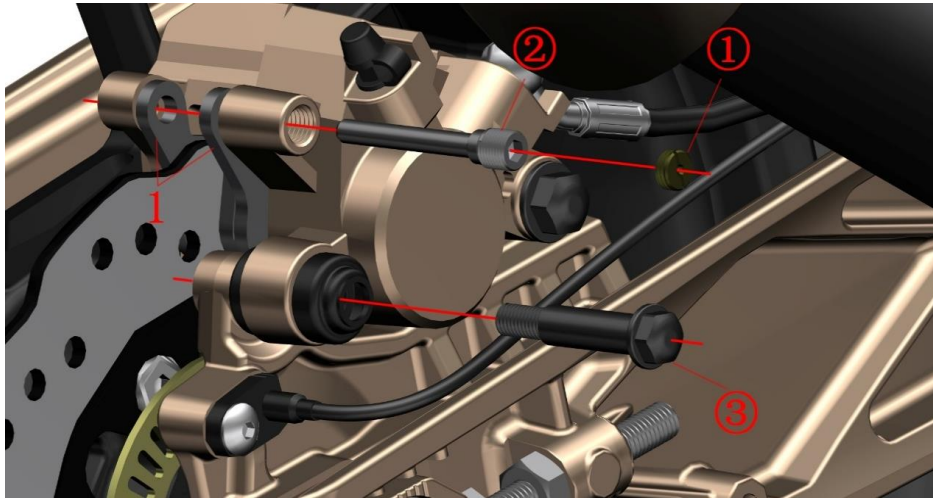

FIG.6 REAR FORKLIFT COMPONENT		Rear inner mudguard	CHK	
			ADJ	
NO.	PART NO.	PART NAME	QTY	CAUTION
1	1100100-092000	Rear disk brake shoe (HS10)	1	

PROCEDURE:

● Get rid of brake shoe

Remove the nut with a screwdriver ①.

Remove the pin shaft ② with the inner hexagon tool.

Use the sleeve to remove the sliding shaft ③.

Remove the rear disc brake (1).

● Replace brake shoe

Push the clamp piston to the end of the arrow, as shown in the lower left corner. In order to reduce the resistance, the cross bolts on the main pump oil cup can be removed before removing the upper cover and sealing rubber pad. After all, you should recover in time.

Replace the new disc brake disc, the brake disc must be stuck to the card slot, as shown in the lower right corner.

Lock the pin shaft ② with the inner hexagon tool.

Use the sleeve to lock the sliding shaft ③.

Lock the nut ① with a screwdriver.

Repeatedly step on the brake pedal until the braking force is restored.

CAUTION:

● Check the brake disc and brake disc on a regular basis.

● It is suggested that the qualified maintenance unit should replace the brake disc in pairs.

● Please refer to the "pedal, shift lever assembly" for adjusting the height of the brake pedal to the appropriate position after replacement.

● After replacing the brake disc, it should be about 300 km to be fully integrated to achieve the best braking effect. Adequate braking distance should be set aside during grinding.

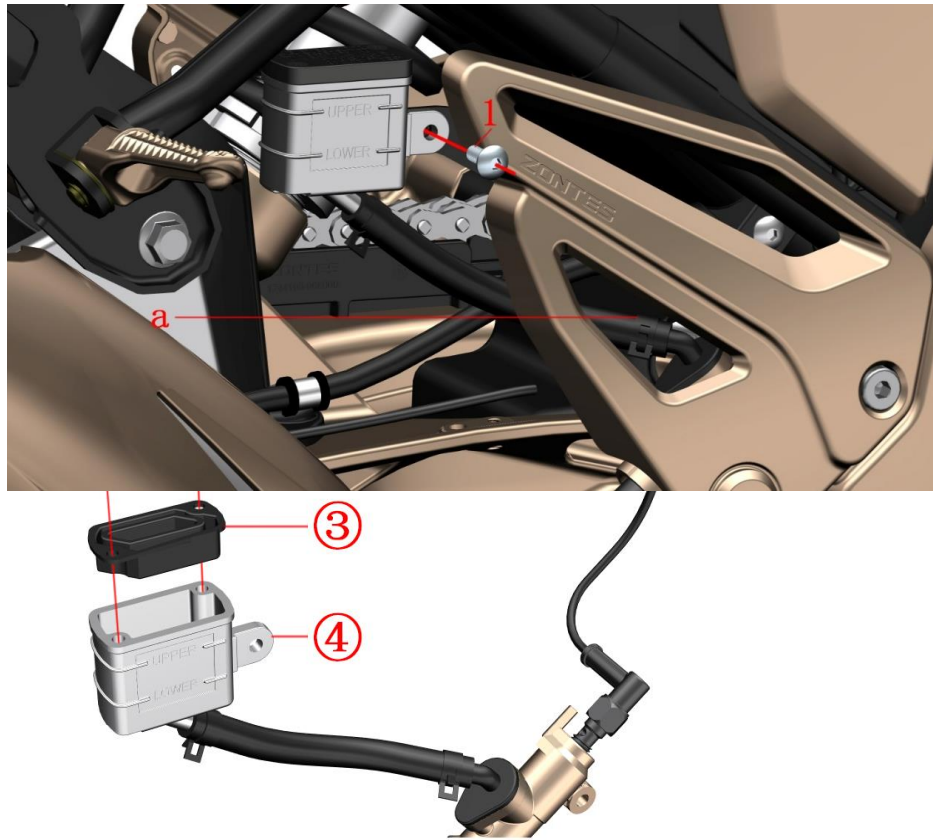

FIG.7 REAR FORKLIFT COMPONENT		Add the brake oil to the main pump or rear brake	CHK	
			ADJ	
NO.	PART NO.	PART NAME	QTY	CAUTION
1	1251100-102000	Non-standard bolts M6c×16 (304 stainless steel)	1	

PROCEDURE:

- Add the brake liquid
 - Remove the bolts with the inner hex tool.
 - Pull out the oil cup; Should always remain above the line a, parallel to the ground, to prevent the gas from entering the oil road to cause brake failure.
 - Remove the bolts with the phillips screwdriver.
 - Remove the oil lid and seal the rubber pad.
 - The top end of the oil cup is basically parallel to the ground, adding DOT4 brake fluid; Make sure the liquid level is between "UPPER" and "LOWER".
 - Reset
 - Step on the brake pedal continuously and make sure that the motorcycle can be driven when the brake is back to normal.

CAUTION:

- The motorcycle level should be fixed and checked.
- Periodically check whether the liquid level of the brake fluid is between "UPPER" and "LOWER".
- If the liquid level is below "LOWER", check the brake disc wear condition and the brake system leakage first.
- If swallowed brake fluid, the poison control center or hospital should be contacted immediately; If eye contact, apply clean water and seek medical treatment immediately.
- Keep the brake fluid away from children and pets.
- Do not flush the oil cup directly with high pressure water.
- It is strictly prohibited to mix water, dust, impurities and liquids of silicic acid or petroleum systems, otherwise it will cause serious damage to the braking system.

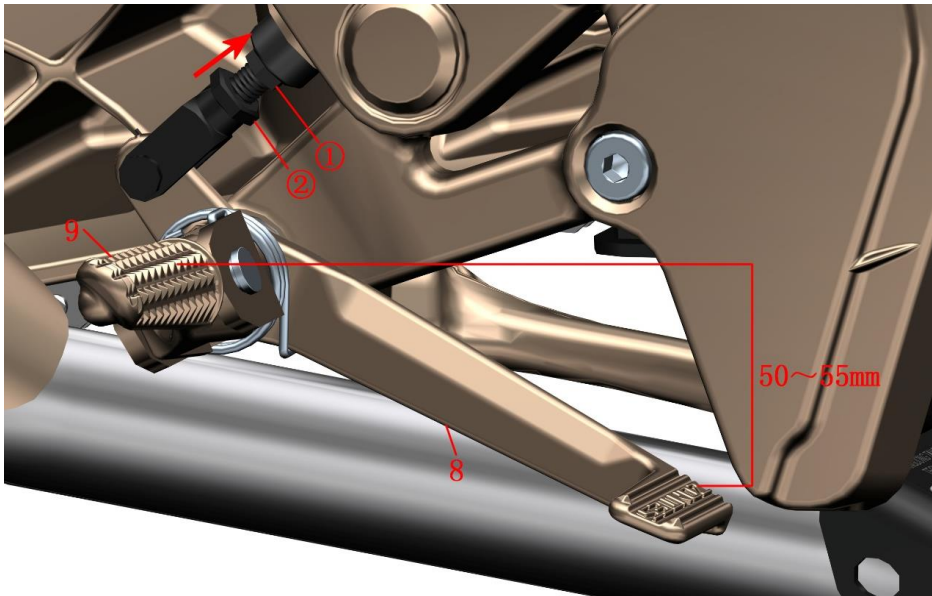
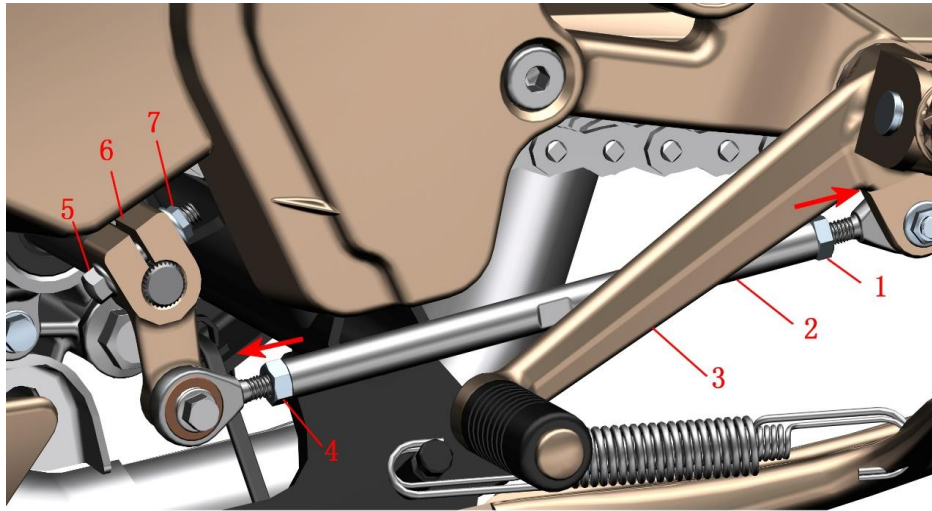

FIG.1 PEDAL COMPONENT		Pedal height adjustment		CHK	
NO.	PART NO.	PART NAME	QTY	ADJ	
1	1250301-018093	GB6170M6—LH (environmental color)	1		
2	1274100-041000	Shift lever adjusting lever	1		
3	1274100-040000	Shift lever rocker arm	1		
4	1250301-049093	GB6170M6 (environmental color)(5 pcs/after-sale)	1		
5	1250104-016093	GB16674M6×28 (chroming)	1		
6	1274100-039000	Shift lever key rocker arm	1		
7	1250303-040093	GB6177.1M6 (environmental color)(5 pcs/after-sale)	1		
8	1274100-004000	Brake pedal	1		
9	1274100-048000	Front right foot pedal	1		

PROCEDURE:

● Shift lever height adjustment

With open end wrench nut (1), nut (4), respectively, in the direction of the arrow to loosen, turn adjusting screw with 8 # open end wrench on the groove position adjustment to the appropriate height, then lock nut (1), nut (4). If above method suitable position once the nut, bolt (5) can be removed, use a screwdriver to spline radial (6) the middle slot open slightly pull out at the same time, transferred to the appropriate height after assembly, pay attention to align the middle of the spline grooves.

● Brake pedal height adjustment

With open end wrench nut (2) in the direction of the arrow to loosen, turn adjusting screw (1) to being stamped on the brake pedal position control and the top of the foot levers below 50 to 55 mm. The adjusting screw (1) fixed lock nut (2) again.

CAUTION:

- The motorcycle should be supported in the adjustment process to prevent accidental damage.
- The lever height of the shift lever should be reasonable, otherwise it will affect the driving experience.
- The brake pedal height should be reasonable, otherwise the brake disc and the brake disc will always have friction to affect the service life, which may lead to brake failure.

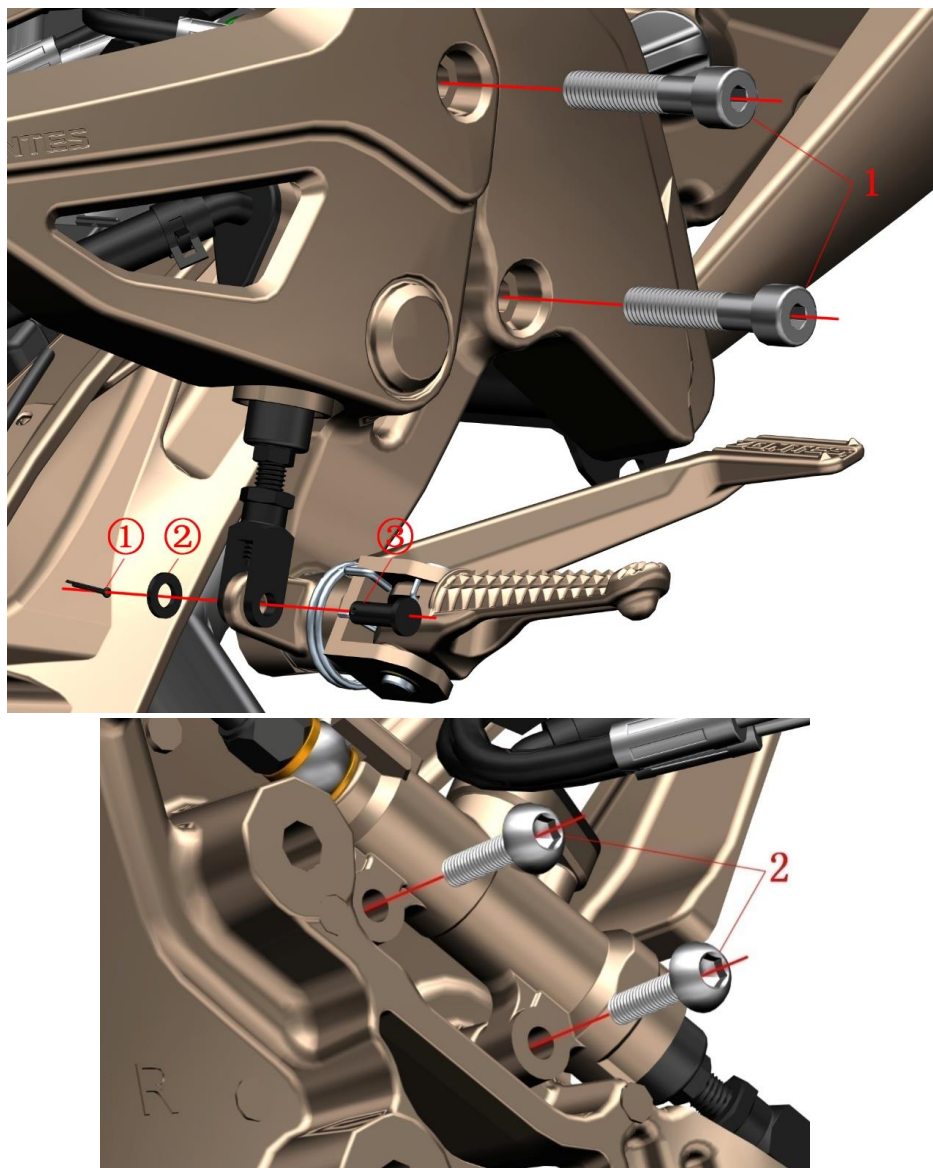



FIG.2 PEDAL COMPONENT		Right pedal support component-1	CHK	
NO.	PART NO.	PART NAME	ADJ	
1	1251100-083094	Non-standard bolts M10×1.5×50	2	CAUTION
2	1251100-121093	Non-standard bolts M6X25 (environmental color)	2	

PROCEDURE:

- Right foot pedal support component
- Use pliers to remove the opening pin ① and remove the washer ② and pin ③.
- Remove the bolts (1) with the inner hex tool.
- Turn the right foot bracket component to the back and remove the bolt (2).

CAUTION:

- When turning over to the back, protect the foot stand and the nearby parts to prevent scratches.
- When flipping, pay attention to force to prevent damage to the disc brake pipe.
- In the process of disassembly, the motorcycle should be properly supported to prevent accidental incline.

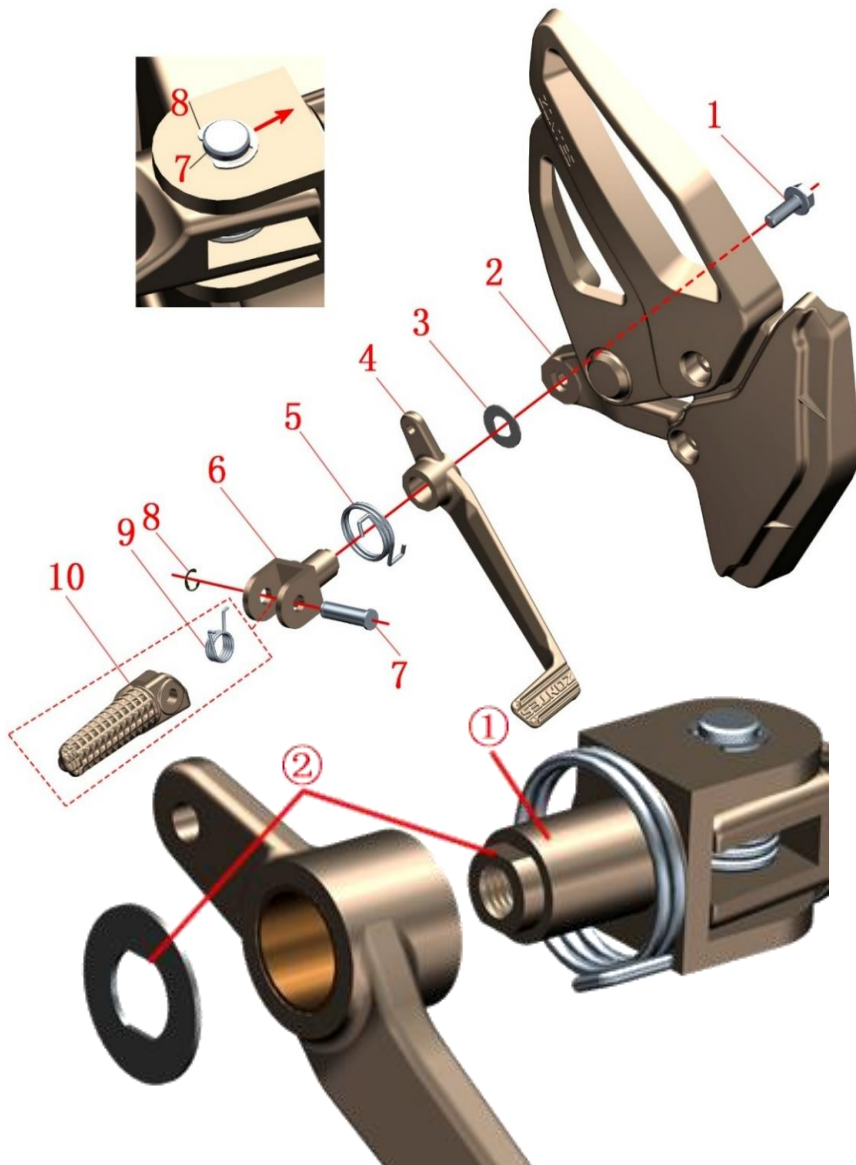

FIG.3 PEDAL COMPONENT		Right pedal support component-2	CHK	⚠
			ADJ	
NO.	PART NO.	PART NAME	QTY	CAUTION
1	1251100-123093	Non-standard bolts M8X25 (environmental color)	1	
2	1274100-036000	Right foot pedal support	1	
3	1251500-048000	Foot pedal support gasket	1	
4	1274100-004000	Brake pedal	1	
5	1260100-092000	Brake pedal spring	1	
6	1274100-035000	Foot pedal support	1	
7	1274100-012000	Foot pedal pin shaft	1	
8	1264100-006000	Foot pedal spring	1	
9	1264100-004000	Front and rear foot pedal spring	1	
10	1274100-048000	Front and rear foot pedal	1	

PROCEDURE:

● Front and rear foot pedal

Get rid of the spring (8), remove the foot pedal (7), and then get rid of the front right foot pedal (10) and foot pedal spring (9).

● Brake pedal

Remove the bolts (1) with the club spanner. Pull the foot support (6) to the axial direction. Remove the support pad (3) and the right foot bracket(2); Remove the brake pedal (4). Remove the brake pedal spring (5).

CAUTION:

● Smooth grease on the surface of the foot support to reduce the brake pedal resistance.

● When reassembling, pay attention to the alignment of the support gasket and the support flange to assemble in place.

● In the process of disassembly, the motorcycle should be properly supported to prevent accidental incline.

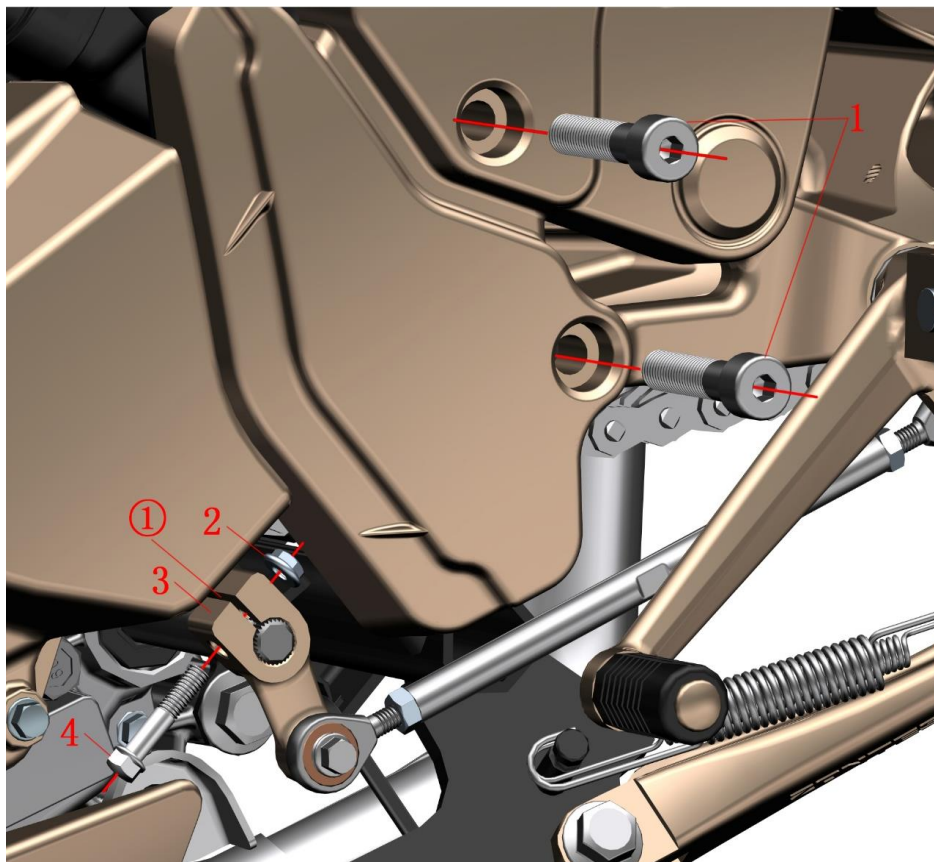



FIG.4 PEDAL COMPONENT		Left pedal support component-1		CHK	
NO.	PART NO.	PART NAME	QTY	ADJ	
1	1251100-083094	Non-standard bolts M10×1.5×50	2		
2	1250303-040093	GB6177.1M6 (environmental color)(5 pcs/after-sale)	1		
3	1274100-039000	Shift lever key rocker arm	1		
4	1250104-016093	GB16674M6×28 (chroming)	1		

PROCEDURE:

- Left foot pedal support component
- Remove the nut (2) by using the spanner wrench, remove the bolt (4), and insert a screwdriver into the slot ① to push the spline rocker (3) slightly apart and pull it out from the engine shift shaft.
- Remove the bolts (1) with the inner hexagon tool and remove the left foot support components.

CAUTION:

- Open the spline rocker arm to take care of the strength to prevent damage.
- In the process of disassembly, the motorcycle should be properly supported to prevent accidental incline.

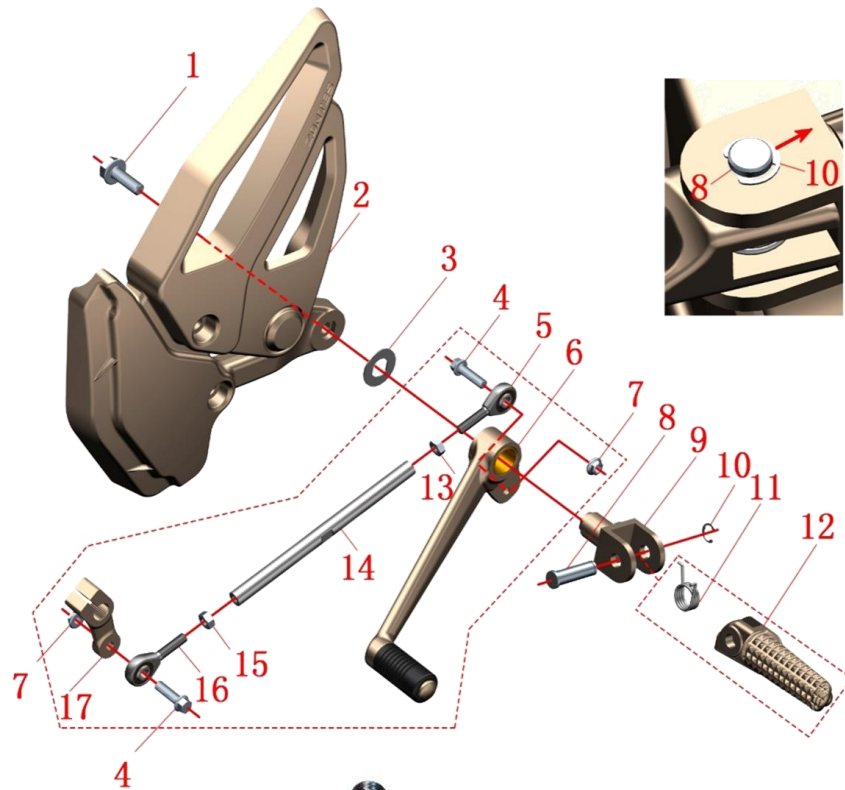

FIG.5 PEDAL COMPONENT		Left pedal support component-2	CHK	CAUTION
			ADJ	
NO.	PART NO.	PART NAME	QTY	
1	1251100-123093	Non-standard bolts M8X25(environmental color)	1	
2	1274100-037000	Left foot pedal support	1	
3	1251500-048000	Foot pedal support gasket	1	
4	1251100-061093	Hexagonal flange bolts (environmental color zinc)	2	
5	1274100-043000	Bearing SALJK6C	1	
6	1274100-040000	Shift lever rocker arm	1	
7	1250303-040093	GB6177.1M6 (environmental color)(5 pcs/after-sale)	2	
8	1274100-012000	Foot pedal pin shaft	1	
9	1274100-035000	Foot pedal seat	1	
10	1264100-006000	Foot pedal spring	1	
11	1264100-003000	Front left foot pedal spring	1	
12	1274100-046000	Front left foot pedal	1	
13	1250301-018093	GB6170M6—LH (environmental color zinc)	1	
14	1274100-041000	Shift lever adjusting lever	1	
15	1250301-049093	GB6170M6 (environmental color)(5 pcs/after-sale)	1	
16	1274100-042000	Bearing SAJK6C	1	
17	1274100-039000	Shift lever key rocker arm	1	

PROCEDURE:

●FRONT RIGHT FOOT PEDAL

With the tool to remove the card spring (10), the foot pin shaft (8) will be removed, then the front left foot step (12), foot twist spring (11)

●SHIFT LEVER COMPONENT

Remove the bolt (1) with a plum spanner and pull the foot support (9) in the direction outward. Remove the support pad(3) and the left foot bracket (2); Remove the shift lever assembly. Once with a ring spanner remove the nut (7), bolt (4), the shift lever treadle rocker rocker arm (6), shift lever key rocker arm (7) removed.

Loosen the nut (13) 、(15) with the open spanner, remove the adjusting rod (14), and then separate the joint bearing (15)、(16)

CAUTION:

- In the process of removing, you should fix the bike to prevent from the accident.
- Pay attention to the hexagonal nuts at both ends of the joint bearing and adjusting rod (the right hand side of the engine shift shaft, near the foot to the left) when reassembling.
- Pay attention to the alignment of the support gasket and the support flange to assemble in place.
- It can reduce the resistance of Shift lever rocker arm by applying lubricating grease evenly on the surface of foot support cylinder.

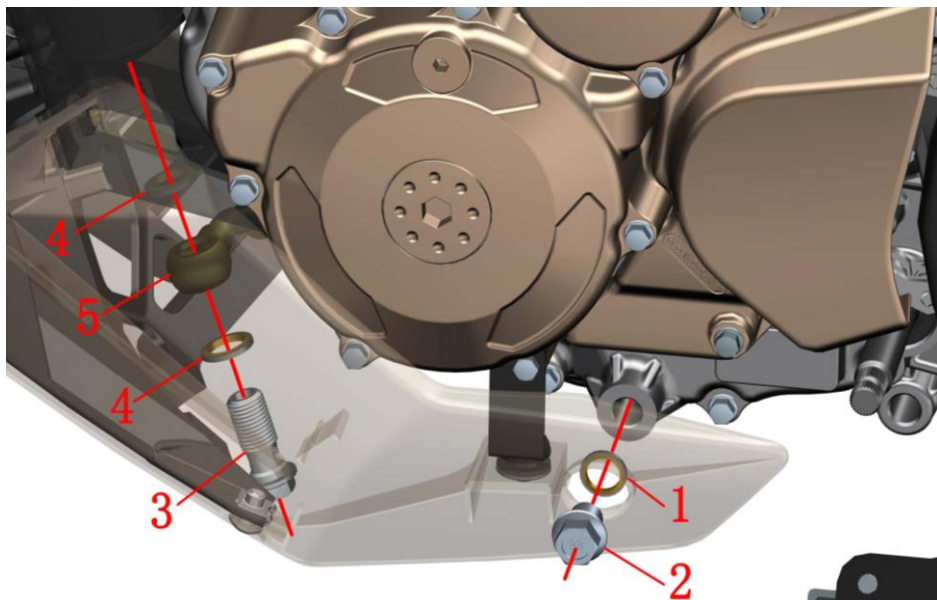

FIG.1 RADIATOR SYSTEM COMPONENT		Release the engine oil	CHK	
NO.	PART NO.	PART NAME	ADJ	
1	1244100-033000	Combined sealing gasket12×φ20×2	1	
2	1251100-066093	M12×1.5×15 oil drain bolt (color zinc)	1	24±4N.m
3	1251100-089094	Oil bolt M14×1.50×32(color zinc)	1	
4	1244100-034000	Combination sealing gasket φ14×φ20×2	2	
5	1244100-070000	Engine oil intake pipe	1	
6	1251100-102000	Non-standard bolts M6×16 (304 stainless steel)	1	
7	1274101-015000	ZT250-S flanging sleeve(φ6.4×φ9×6+φ20×2)(5 pcs/af	1	
8	1251401-013000	φ10×14 dowel pin(5 pcs/after-sale)	1	
9	1051454-014000	9.8×2.5 Acrylate rubber o-rings	1	
10	1251100-061093	M6×22 Hex flang bolt thread level 8.8 (color zinc)	1	

PROCEDURE:

●Put on the engine oil

Place the oil pan at the bottom, use the sleeve to remove the oil bolt (2) and combination sealing gasket (1), and then remove the remaining oil in the engine. Remove the oil bolts (3) and the sealing gasket (4) to remove the oil from the frame tube. Clean all the material with a clean non-woven cloth. Refer to the instructions for detailed steps to replace the oil.

●Right lower fairing cover

Use the inner hex tool to remove the bolts (6) and the flange (7). The guide cover should not be removed completely.

●Engine oil intake pipe

Remove the bolt (9) with the sleeve, pull the engine into the tubing (5) and pull it out, and remove the O-shape ring (9) and the pin(8).

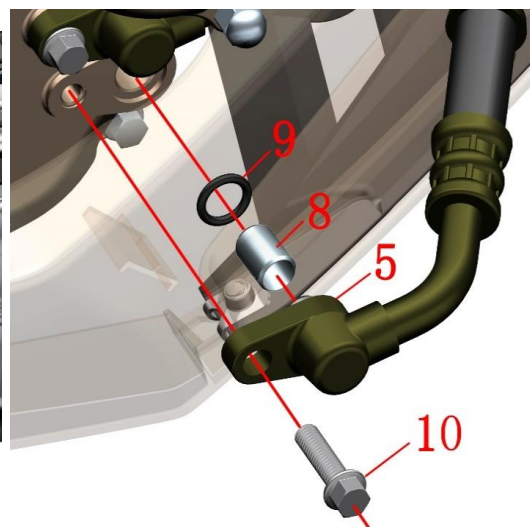
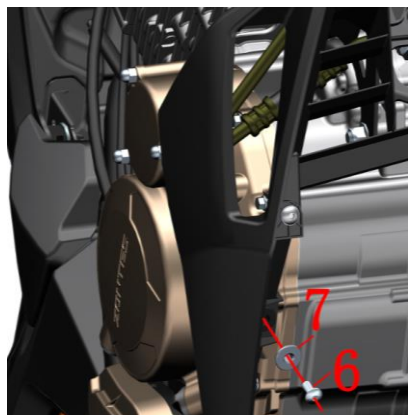

CAUTION:

●It is strictly forbidden to remove the cooling system in the heat engine, and it should wait for the engine and muffler to completely cool down before it can be removed.

●The waste oil needs to be uniformly recovered and returned to the qualified institutions; It is forbidden to dump pollution or water sources at will.

●It is recommended to replace the oil in the oil at the same time and replace the oil bolts, combination gasket and O-shape ring to prevent oil leakage.

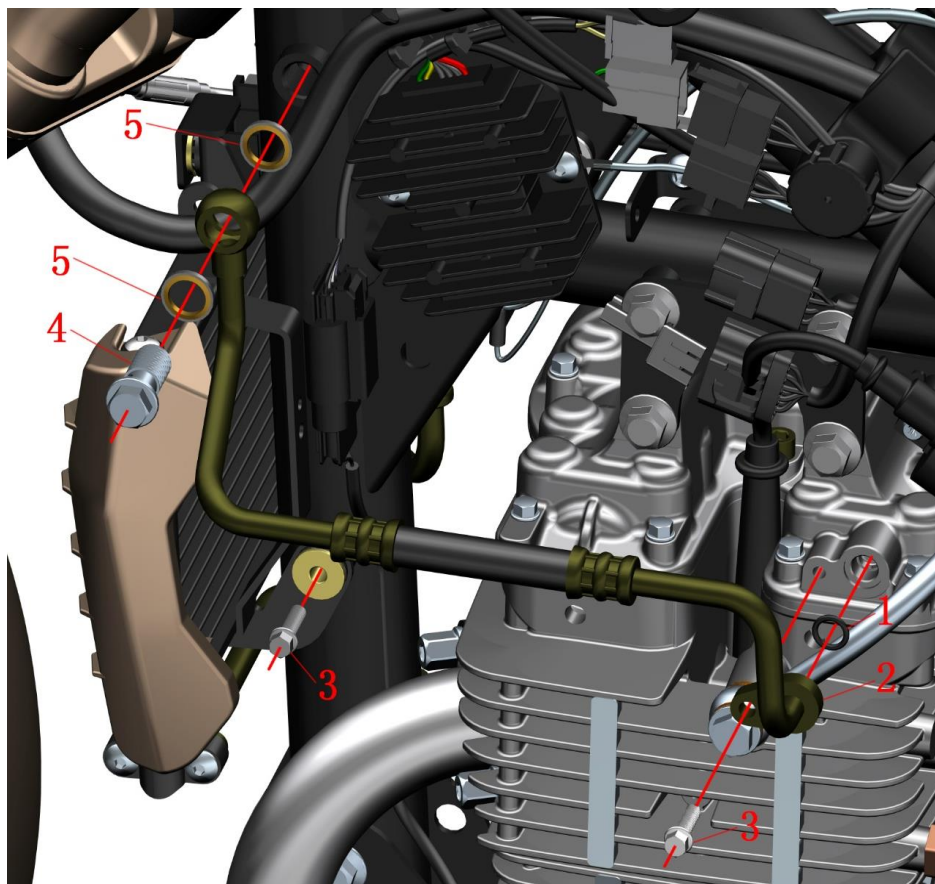



FIG.2 RADIATOR SYSTEM COMPONENT		The oil pipe near the frame	CHK	
NO.	PART NO.	PART NAME	ADJ	
1	1051454-014000	9.8×2.5 Acrylate rubber o-rings	1	
2	1244100-071000	ZT250-R Frame bypass oil pipe	1	
3	1251100-061093	M6×22 Hex flang thread bolt	2	
4	1251100-089094	Oil bolt M14×1.50×32 (environmental zinc)	1	
5	1244100-034000	Combination seal gasketφ14×φ20×2	2	

PROCEDURE:

- Frame bypass oil pipe
Remove oil bolt (4) and combination seal gasket (5) with sleeve.
Remove the bolt (3) near the engine with a sleeve. Then remove the frame bypass tube, and finally remove the O-shape ring (1).
- Remove the bolt (3) near the muffler elbow upward side with a sleeve. If you do not need to remove the heat dissipation assembly, do not remove the bolt.

CAUTION:

- It is forbidden to disassemble the heat dissipation system when it is warmed up. Wait for the engine and muffler to cool completely before disassembling.
- The waste oil needs to be recycled and handed over to a qualified organization; it is forbidden to dump the polluted environment or water at will.
- Violation is strictly prohibited when removing the bypass pipe from the frame so as to avoid deformation of the sleeve.
- It is recommended to replace oil drain bolts, combination seal gasket, and O-shape ring to prevent oil leakage every time you change the oil.

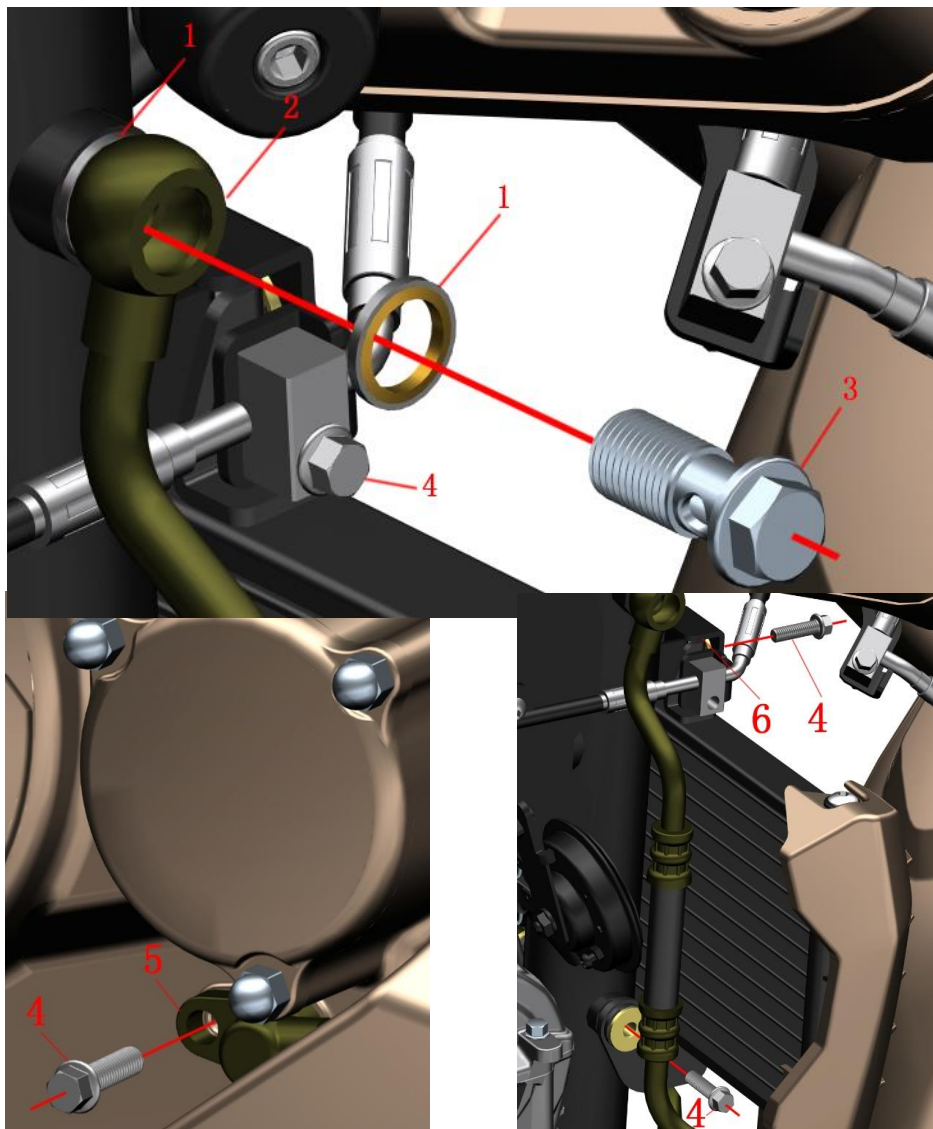

FIG.3 RADIATOR SYSTEM COMPONENT		Radiator component-1	CHK	⚠
NO.	PART NO.	PART NAME	ADJ	
1	1244100-034000	Combination seal gasket φ14×φ20×2	2	CAUTION
2	1244100-069000	ZT250-R Oil cooler outlet pipe	1	
3	1251100-089094	Oil bolt M14×1.50×32 (environmental color zinc)	1	
4	1251100-061093	M6×22 Hex Flange Thread Bolt (8.8 grades/envirom)	3	
5	1244100-068000	ZT250-R Oil cooler inlet pipe	1	
6	1274100-079000	ZT250-R Front disc brake tube bracket 2	1	

PROCEDURE:

- Oil cooler outlet pipe
Remove the oil bolt (3) with a sleeve and remove the seal gasket (1).
Remove the bolt (4) with a tool.
- Oil cooler inlet pipe
Remove the bolt (4) with the sleeve and pull the connector of the oil cooler inlet pipe (5) outward in the axial direction.
- Heat dissipation assembly
Remove the bolt (4) near the bottom of the heat dissipation with a sleeve; then remove the bolt (4) on the front of the heat dissipation and remove the tube bracket (6). Remove the heat dissipation assembly.

CAUTION:

- It is forbidden to disassemble the heat dissipation system when it is warmed up. Wait for the engine and muffler to cool completely before disassembling.
- The waste oil needs to be recycled and handed over to a qualified organization; it is forbidden to dump the polluted environment or water at will.
- When disassembling the oil cooler inlet pipe, violent operation is strictly prohibited to avoid deformation of the liner.
- It is recommended to replace oil drain bolts, combination seal gasket, and O-shape ring to prevent oil leakage every time you change the oil.

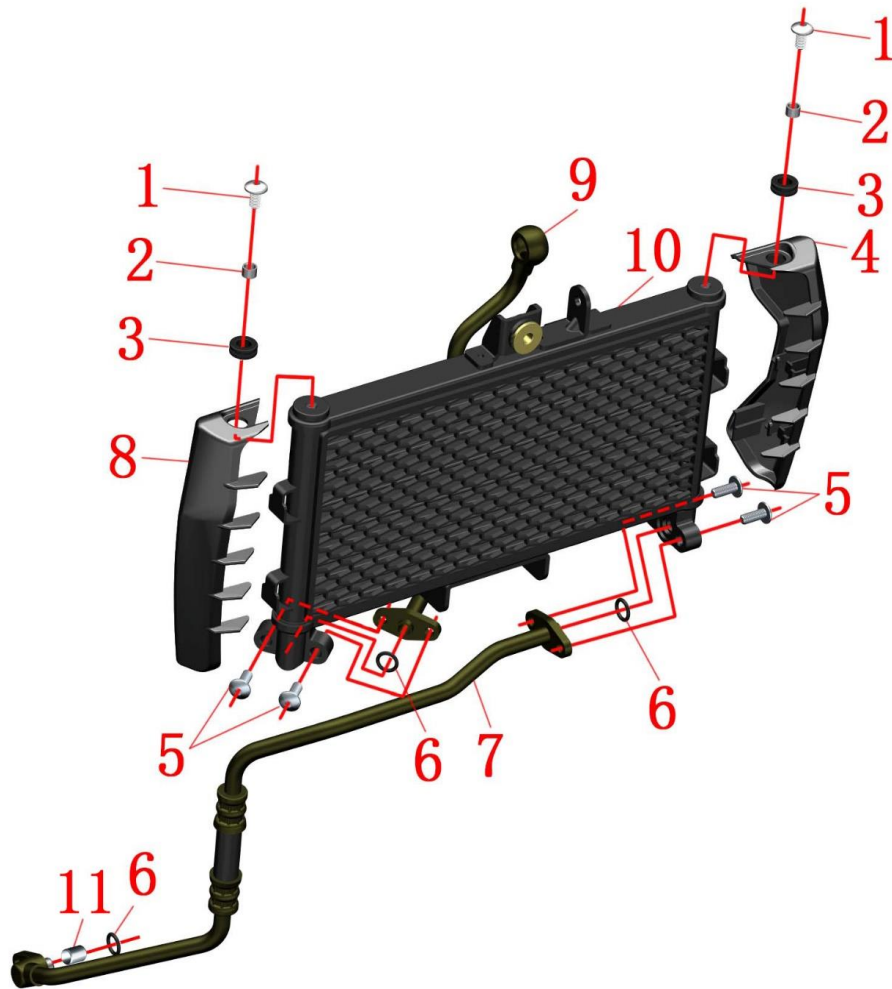

FIG.4 RADIATOR SYSTEM COMPONENT		Radiator component-2	CHK	CAUTION
NO.	PART NO.	PART NAME	ADJ	
1	1251100-101000	Non-standard bolt M6×12 (304 stainless steel)	2	
2	1274100-018000	ZT250-S Muffler anti-hot plate bushing	2	
3	1246400-317000	ZT368T-G muffler hot plate rubber buffer(5 pcs/after-s)	2	
4	4044101-004051	ZT250-R Oil cooler left trim cover (titanium)	1	【1】
	4044101-004052	ZT250-R Oil cooler left trim cover (light grey)		【2】
5	1251100-102000	Non-standard bolt M6×16 (304 stainless steel)	4	
6	1051454-014000	9.8×2.5 Acrylate rubber o—rings	3	
7	1244100-068000	ZT250-R Oil cooler inlet pipe	1	
8	4044101-005051	ZT250-R Oil cooler right trim cover (titanium)	1	【1】
	4044101-005052	ZT250-R oil cooler right trim cover (light grey)		【2】
9	1244100-069000	ZT250-R Oil cooler outlet pipe	1	
10	1274100-084000	ZT250-R Oil cooler	1	
11	1251401-013000	φ10×14 dowel pin(5 pcs/after-sale)	1	

PROCEDURE:

● Oil cooler trim cover

Remove the bolt(1) with the hexagonal tool; remove the left trim cover(4) and the right trim cover(8). Push the bushing(2) out of the buffer(3) and remove the buffer from the trim cover

● Oil cooler inlet pipe

Remove the bolt(5) with the hexagonal tool, separate the oil inlet pipe(7) from the oil cooler(10), and remove the O-shape rings(6) at both ends, and the pin(11).

● Oil cooler outlet pipe

Remove the bolt(5) with the hexagonal tool, separate the oil outlet pipe(9) from the oil cooler(10), and then remove the O-shape ring(6).

CAUTION:

● It is forbidden to disassemble the heat dissipation system when it is warmed up. Wait for the engine and muffler to cool completely before disassembling.

● The waste oil needs to be recycled and handed over to a qualified organization; it is forbidden to dump the polluted environment or water at will.

● When disassembling the oil cooler inlet pipe, violent operation is strictly prohibited to avoid deformation of the liner.

● It is recommended to replace oil drain bolts, combination seal gasket, and O-shape ring to prevent oil leakage every time you change the oil.

● 【1】 use for orange&dark blue motorcycle. 【2】 use for green&blue motorcycle.

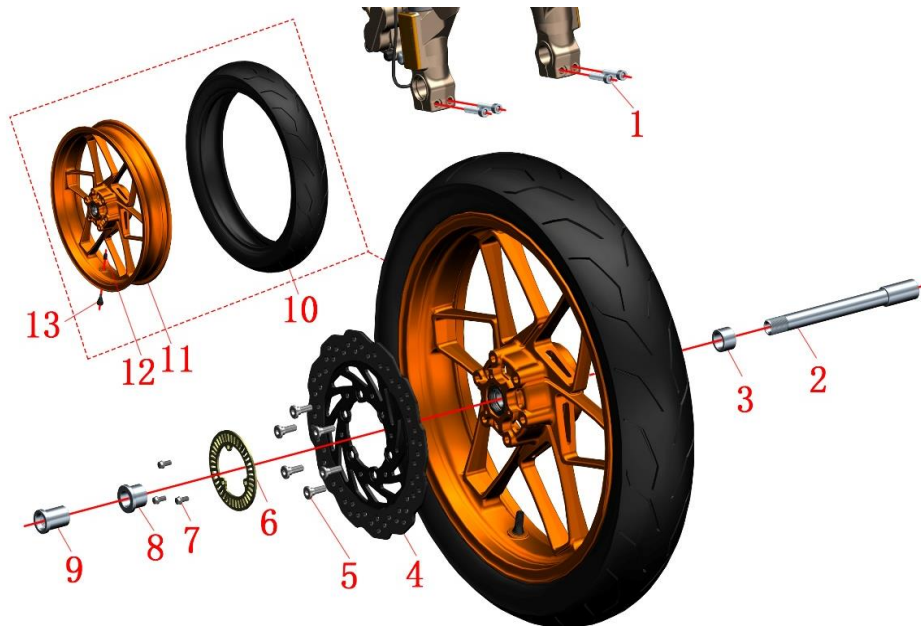

FIG.1 FRONT FORK COMPONENT		Front wheel assembly	CHK	CAUTION
			ADJ	
NO.	PART NO.	PART NAME	QTY	
1	1250205-023000	GB70.1 Hexagon M8×35 (environmental color zinc)	4	
2	1094100-033000	ZT250-R Front wheel hollow shaft	1	
3	1094100-008000	ZT250-R Front wheel left sleeve	1	
4	1104100-004000	ZT250-S Front brake disc (260×4.5)	1	
5	1251100-117093	Non-standard hexagonal bolt M8×25	6	
6	1274100-054000	ABS9 Anti-lock system gear ring	1	
7	1250104-006097	GB16674M6×12 (chrome/HH)	3	
8	1094100-036000	ZT250-R Front wheel right axle sleeve	1	
9	1094100-037000	ZT250-R Front wheel right fixed axle sleeve	1	
10	1230100-077000	ZT250-S110/70R17(CM609)Tires	1	250kPa
11	1094100-040000	ZT250-S Bright orange front rim (3.00×17)	1	orange
	1094100-042000	ZT250-S Bright blue front rim (3.00×17)		blue
	1094100-046000	ZT250-S Bright green front rim (3.00×17)		green
	1094100-056000	ZT250-S black front rim (3.00×17)		black
12	1230200-006000	HJ100-D Tire valve cap	1	
13	1230100-047000	HJ125-3A Environmental vacuum valve (TR-412)	1	

PROCEDURE:

●Tire and rim assembly

Remove the 2 bolts (1) on the left front shock absorber bottom with the Allen tool. Hold the front wheel first and then remove the hollow shaft (2) with the internal hexagon tool, remove the left sleeve (3), and move the front wheel assembly downward to remove the right sleeve (8) and front wheel assembly. Finally, use the hexagonal tool to remove the 2 bolts (1) of the right front shock absorber and remove the right fixing sleeve (9).

●Brake disc、ABS gear ring

Remove the bolt(7) with the sleeve and remove the ABS gear ring(6). Remove the bolt(5) with the hexagonal tool and remove the brake disc(4).

●Tire and rim assembly

Remove the valve cap(12) and use a tool to release the air, and then use a professional puller to remove the tire(10). Finally remove the valve with a suitable tool(13).

The rim colour orange use for orange vehicle; green use for bright green vehicle; blue use for bright blue vehicle; black use for dark blue vehicle.

CAUTION:

●Use suitable tools to support the motorcycle to prevent accidents caused by motorcycle incline during disassembly; no individual operation.

●Always be vigilant in the entire process to prevent accidents.

●Take care when removing tyres and rims to prevent damage to the material.

●After replacing tires, check for leaks and balance.

●Unqualified tire repair fluid may erode rims and cause safety hazards.

●Insufficient tire pressure may cause steering jitter, abnormal wear, etc.; tire pressure in summer is too high.

●Maintenance items

Tires: The tires should be regularly inspected for cracks, fracturing, air pressure, etc. If you have worn out the tread wear indicator, you must replace the tire of the same model. Refer to the manual for details.

Rim: Check the rim for signs of deformation, cracks, etc. Rotate the rim horizontally to check if there is any catch, swing, etc.

Axle: Use dial indicator to check for deformation and bending.

Brake disc: After replacing the brake disc, the new brake disc should be operated for about 300 kilometers to fully run in order to achieve the best braking effect. Be careful to allow enough braking distance during running-in.

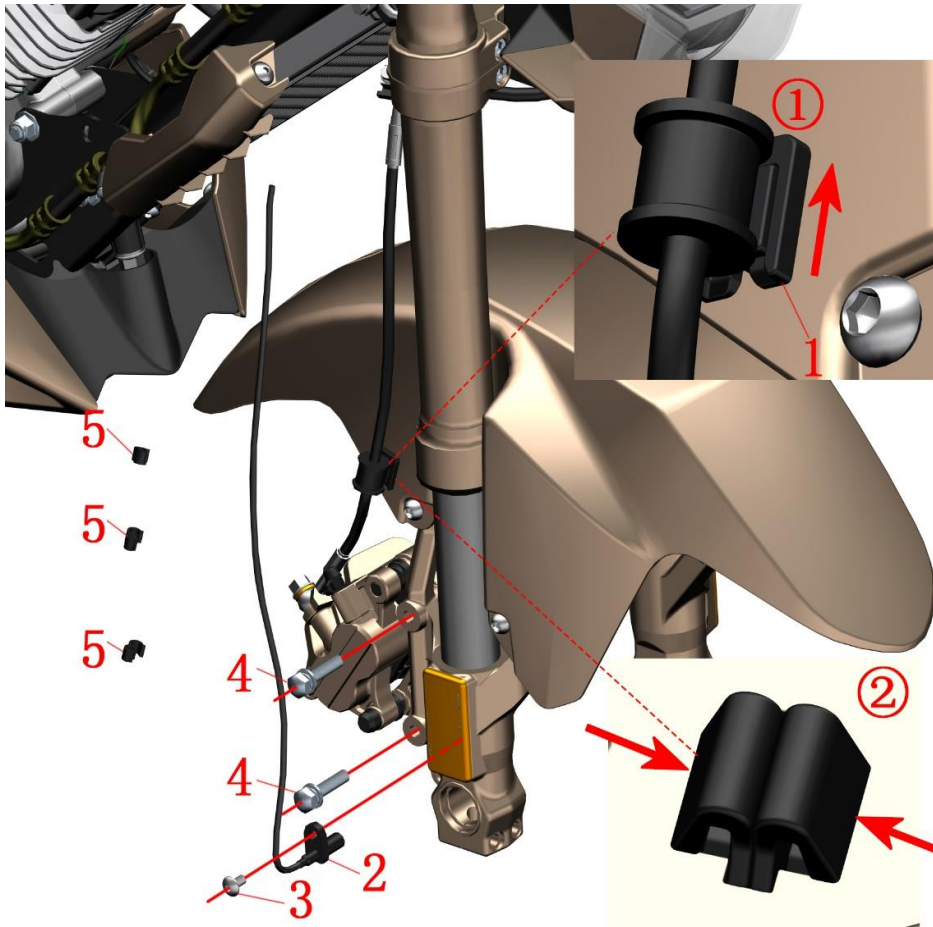

FIG.2 FRONT FORK COMPONENT		Front wheel speed sensor assembly		CHK	⚠
				ADJ	
NO.	PART NO.	PART NAME	QTY	CAUTION	
1	1274100-014000	ZT250-S Front disc brake pipe clamp	1		
2	1184200-045000	DF30 wheel speed sensor	1		
3	1251100-102000	Non-standard bolt M6×16 (304 stainless steel)	1		
4	1251100-080094	Non-standard bolt M8×37 (environmental color zinc)	2		
5	1224100-044000	Wheel speed sensor clamp	3		

PROCEDURE:

● Front disc brake pipe clamp

Pull down the clamping plate in the direction of the arrow ① and remove it. Use the pliers to clamp it slightly in the direction shown by ② in the front fender. Use the pliers to clamp the pipe to the outside and remove the tube clamp (1) from the fender. Slightly open in the direction indicated by ② to remove completely from the disc brake tube cushion rubber.

● Wheel speed sensor

Pull out the plug of the wheel speed sensor (2) from the main harness; then remove the clamp (5). Remove the bolt (3) with the hexagonal tool and remove the sensor.

● Front disc brake caliper

Remove the bolt (4) with a sleeve to allow the caliper to droop naturally. It is forbidden to invert the caliper to prevent the air from entering and causing the brake to malfunction.

CAUTION:

- The motorcycle support should be fixed during disassembly to prevent accidents caused by incline.
- Remove the tube clamps, sensor clamps should pay attention to strength.

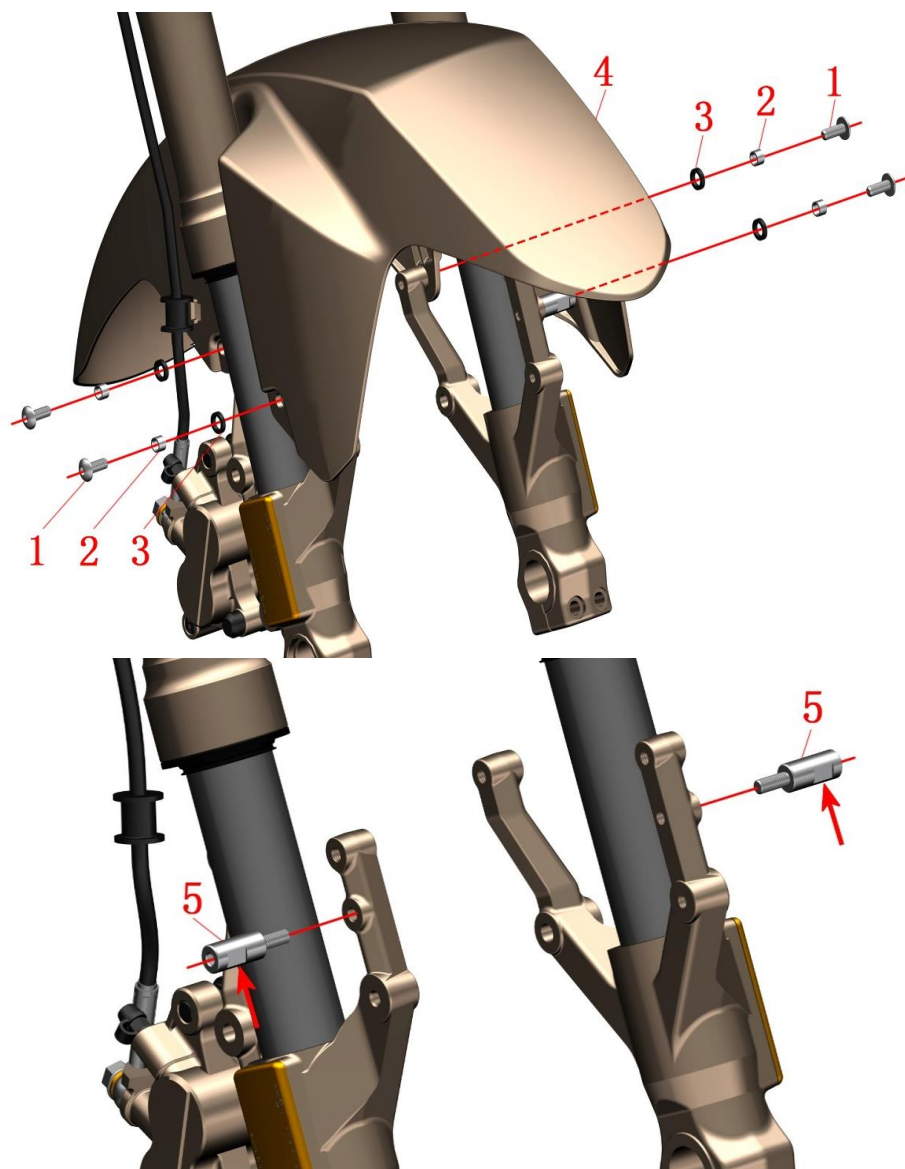

FIG.3 FRONT FORK COMPONENT		Front mudguard assembly	CHK	CAUTION
			ADJ	
NO.	PART NO.	PART NAME	QTY	
1	1251100-102000	Non-standard bolt M6×16 (stainless steel)	4	
2	1274100-018000	ZT250-S Muffler anti-hot plate bushing	4	
3	1244100-037000	φ12×φ8.5×2.5 Circular buffer	4	
4	4044100-005051	ZT250-S Front mudguard (titanium)	1	orange
	4044100-005052	ZT250-S Front mudguard (bright grey)		blue&green
	4044100-005063	ZT250-S Front mudguard (dark blue)		bark blue
5	1274200-035194	ZT310 Front mudguard liner(black zinc)	2	

PROCEDURE:

●Front mudguard

Hold the front mudguard(4) with hands and remove the four bolts(1) with the hexagonal tool. Remove the bushing(2) and cushion rubber(3).

Remove the front mudguard(4).

●Front mudguard bushing

Remove bushing with 10mm open end wrench(5).

CAUTION:

●The motorcycle support should be fixed during disassembly to prevent accidents caused by incline.

●Attention should be paid when removing the front mudguard to prevent scratches.

●Orange use for orange vehicle; green&blue use for bright green&bright blue vehicle; dark blue use for dark blue vehicle.

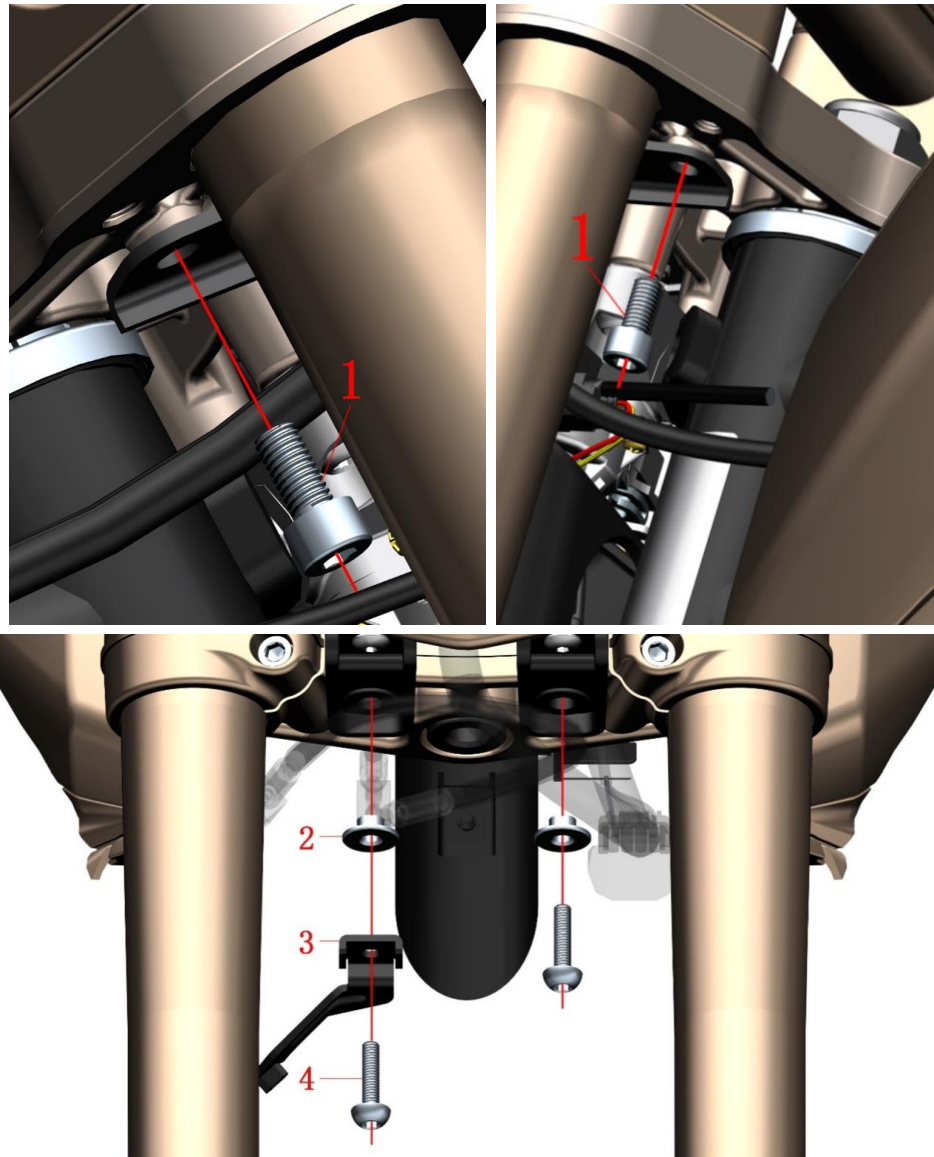

FIG.4 FRONT FORK COMPONENT		Head assembly 1	CHK	
NO.	PART NO.		ADJ	
1	1250205-040095	GB70.1 Hexagonal bolt M8×16	2	
2	1274101-015000	ZT250-S flanging sleeve(φ6.4×φ9×6+φ20×2)(5 pcs/af)	2	
3	1274100-078000	ZT250-R Front disc brake tube bracket No.1	1	
4	1251100-121093	Non-standard bolt M6×25 (environmental color)	2	

PROCEDURE:

●Head assembly

Use your hand to hold the head assembly and remove the two bolts(1) on both sides of the upper plate bottom with the hexagonal tool.

Use your hand to hold the head assembly and remove the two bolts(4) on the bottom of the lower plate with the hexagonal tool. Remove the tube bracket(3); remove the flanged bushing(2).

Move the head assembly forward with your hands, and pull all the plugs on the main harness and head, including headlights, instruments, turn signals, electric door locks, etc.

CAUTION:

- The motorcycle support should be fixed during disassembly to prevent accidents caused by incline.
- Take care when unplugging the connector. Never pull it out to avoid damage. When reinstalling, check whether the insert in the plug is misaligned. Check if the tape is missing.

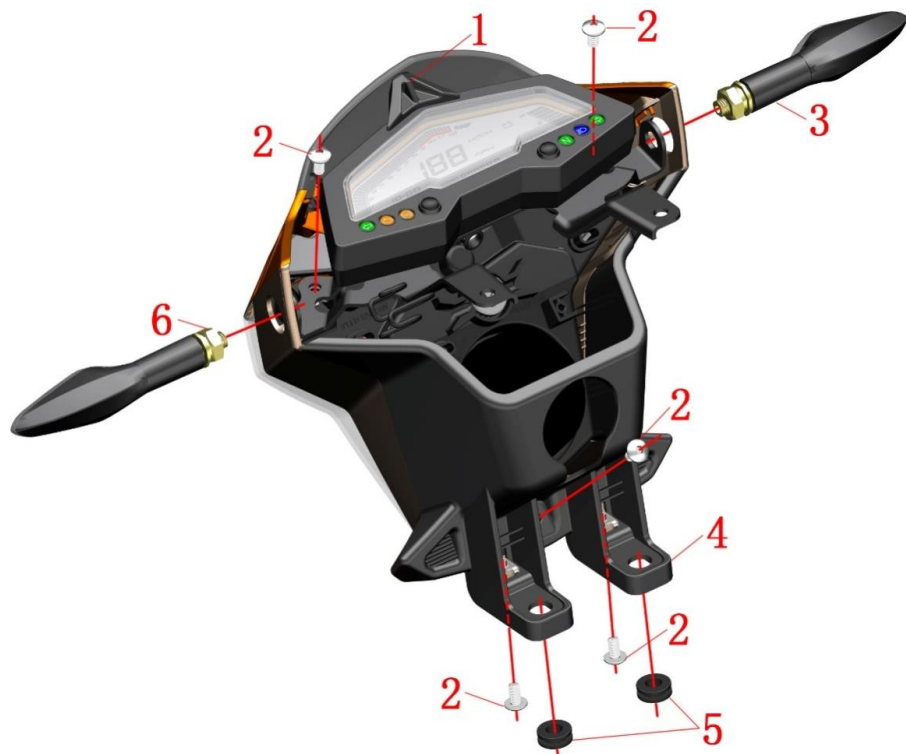

FIG.5 FRONT FORK COMPONENT		Head assembly 2	CHK	
NO.	PART NO.		ADJ	
1	1244100-040000	ZT250-S Head cover cushion rubber	1	
2	1251100-101000	Non-standard bolt M6×12 (304 stainless steel)	4	
3	1174100-006000	ZT250-S Front right turn signal light	1	
4	1224100-026000	ZT250-S Head cover rear shell	1	
5	1244100-137000	ZT250-S Flanging bushing buffer(5 pcs/after-sale)	2	
6	1174100-005000	ZT250-S Front left turn signal light	1	

PROCEDURE:

● Turn signal light

Use an open-end wrench to remove the hex nuts on the right turn signal light(3) and the left turn signal light(6), and remove the spring washers and washers on the turn signal lights.

● Instrument assembly

Remove the two bolts(2) on the upper part of the instrument holder (the top in the left figure) with the hexagonal tool. Remove the instrument assembly and then remove the head cover cushion rubber(1).

● Head cover rear shell

Remove the three bolts(2) at the bottom (at the bottom of the left figure) with the hexagonal tool. Use a flat-blade screwdriver to pick up the upper buckle indicated by① and then apply force to both sides of the head cover rear shell and front assembly in the direction indicated by② to remove the head cover rear shell(4) and put the cushion rubber(5) from the rear shell.



CAUTION:

- The motorcycle support should be fixed during disassembly to prevent accidents caused by incline.
- When using a flat-blade screwdriver to pick up the buckle, pay attention to it. If the strength is too high, the buckle may be easily broken.
- When separating the head cover rear shell, pay attention to the direction and strength of the force to avoid causing the buckle to break.
- Pay attention to distinguish the line color when installing the turn signal light, the left turn signal light beam is orange + green, the right turn signal light beam is bright blue + green.

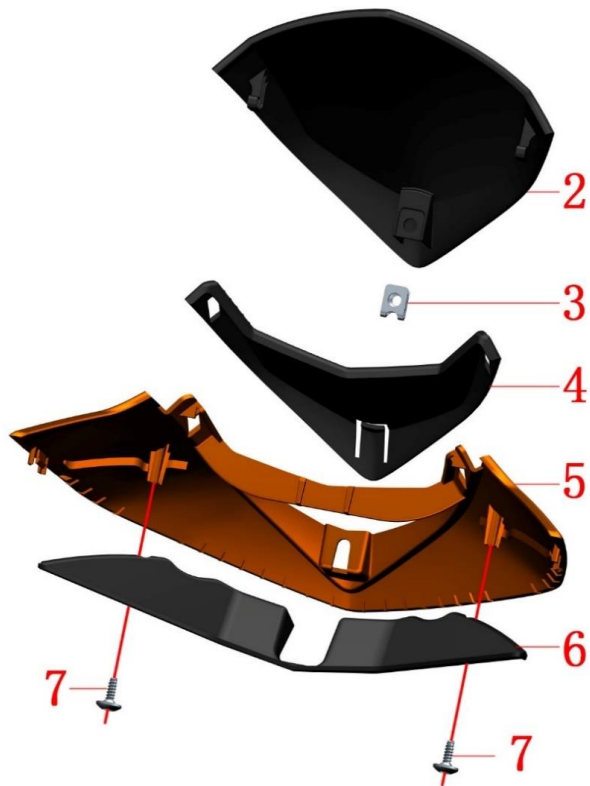
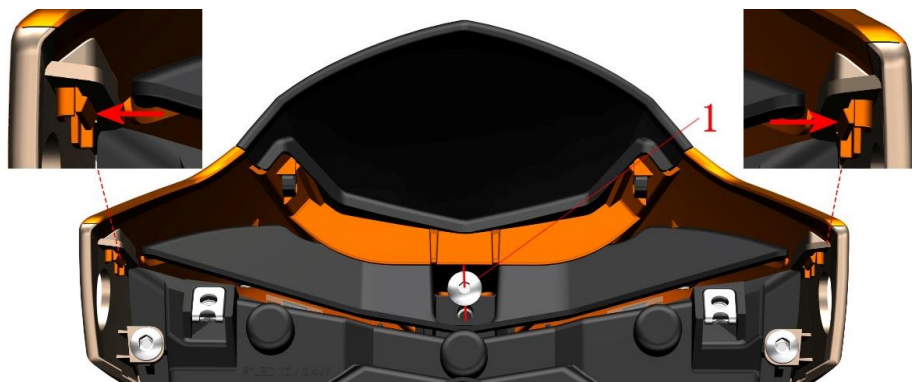

FIG.6 FRONT FORK COMPONENT		Head cover upper part assembly	CHK	⚠
			ADJ	
NO.	PART NO.	PART NAME	QTY	CAUTION
1	1251100-101000	Non-standard bolt M6×12 (304 stainless steel)	1	
2	1224100-001000	ZT250-S Windshield	1	
3	1251300-063093	Plywood M6×11×15(green color)	1	
4	1224100-027000	ZT250-S Head cover sandwich	1	
5	4044100-006033	ZT250-S Head cover upper part(bright orange)	1	orange
	4044100-006064	ZT250-S Head cover upper part(bright blue)		blue
	4044100-006041	ZT250-S Head cover upper part(bright green)		green
	4044100-006063	ZT250-S Head cover upper part(dark blue)		dark blue
6	1224100-031000	ZT250-S Head cover light block	1	
7	1251200-033093	Non-standard self-tapping blot ST4.2×12	2	

PROCEDURE:

● Head cover upper part assembly

Remove the bolt with the hexagonal tool(1).

Press the buckle slightly in the direction of the arrow to separate the headlight upper assembly lower headlamp assembly.

Remove the bolt(7) with the hexagonal tool and remove the light block(6).

Push the tip of the windshield (2) forward with hands, and remove the upper part of the head cover(5) and sandwich(4).

Remove the plywood nut(3) from the windshield(2)

CAUTION:

● Attention should be paid when using the tool to press down the buckle. If the force is too large, the buckle will be easily broken.

● When restoring the bolt(7), the axis of the screw should be perpendicular to the mounting surface of the light barrier, and do not overtighten the pin on the upper part of the head cover.

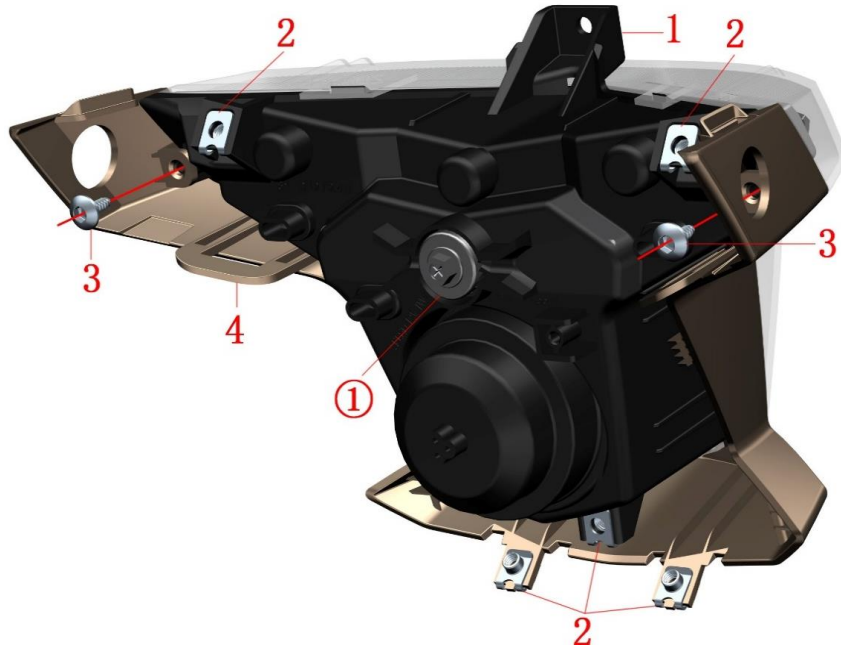

FIG.7 FRONT FORK COMPONENT		Front light assembly	CHK	
NO.	PART NO.		ADJ	
1	1174100-009000	ZT250—S LED Front light	1	
2	1251300-063093	Plywood M6×11×15 (environmental color)	5	
3	1251200-033093	Non-standard self-tapping bolt ST4.2×12 (environmental)	2	
4	4044100-007051	ZT250—S Head cover lower part(titanium)	1	orange
	4044100-007052	ZT250—S Head cover lower part(bright grey)		green&blue
	4044100-007063	ZT250—S Head cover lower part(dark blue)		dark blue

PROCEDURE:

● Front light

Remove the bolt(3) with the hexagonal tool.

Separate the front light(1) and head cover lower part(4).

Separately remove the plywood nut(2) from the front light(1) and the lower part of the head cover(4).

● Adjust the light height

The driver sits on the seat and the motorcycle is upright. The other person uses a cross screwdriver to insert the left or right side of the motorcycle into the zigzag position indicated by the arrows on the left. Rotate the light level adjustment bolt① clockwise or counterclockwise to adjust the light to a suitable position. No need to remove any parts to adjust light height.

CAUTION:

● Attention should be paid when using the tool to press down the buckle. If the force is too large, the buckle will be easily broken.

● When restoring the bolt(7), the axis of the bolt should be perpendicular to the mounting surface of the light barrier, and do not overtighten the pin on the upper part of the head cover.

● The front light use LED light source, which does not need to be replaced or maintained under normal condition. Therefore, the rubber sleeve behind the front light cannot be removed to prevent dust from entering.

● Orange use for orange vehicle; green&blue use for bright green&bright blue vehicle; dark blue use for dark blue vehicle.

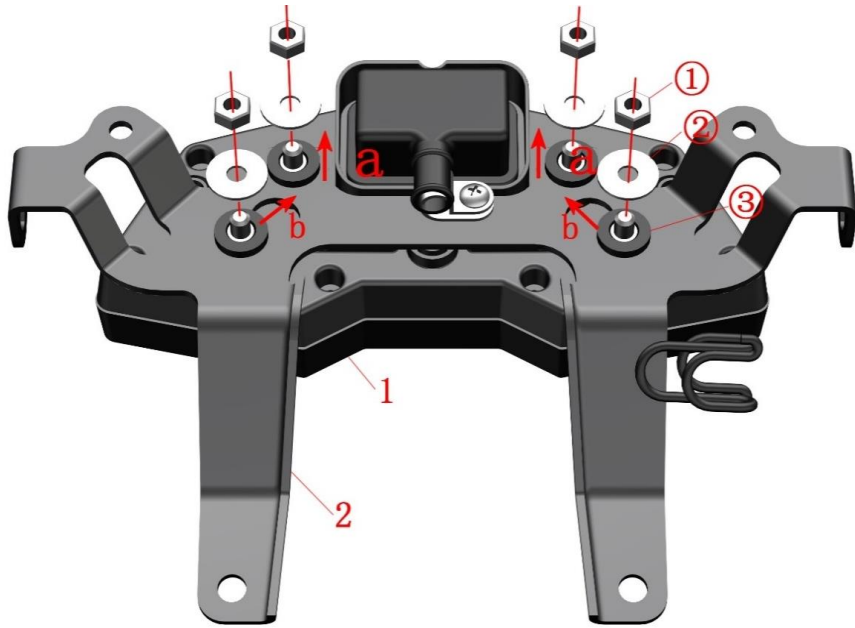

FIG.8 FRONT FORK COMPONENT		Instrument assembly		CHK	⚠
				ADJ	
NO.	PART NO.	PART NAME		QTY	CAUTION
1	1164100-004000	ZT250-R Electronic instrument		1	
2	1274100-019000	ZT250-S Instrument support		1	

PROCEDURE:

● Instrument

Remove the four nuts① and gasket② with the sleeve and then remove the instrument(1).

Four pieces of instrument's own buffer are removed from the meter support(2) in the direction of arrows a and b respectively.

CAUTION:

- When removing the instrument assembly, take care to protect the case and prevent scratches.
- When the assembly is handled, the corner should be tightened. The torque should not be too large to prevent the permanent deformation caused by the excessive deformation of the buffer.
- Do not flush the instrument directly with high-pressure water. Never wipe the instrument with a rag stained with organic solvents such as gasoline, kerosene, alcohol, or brake fluid. Otherwise, the instrument may cause localized cracks or discoloration due to contact with organic solvents.
- Detailed description of the instrument refer to the description of the instrument in the description.
- It is forbidden to operate the instrument when driving a motorcycle, and it is forbidden to leave the direction handle during riding.

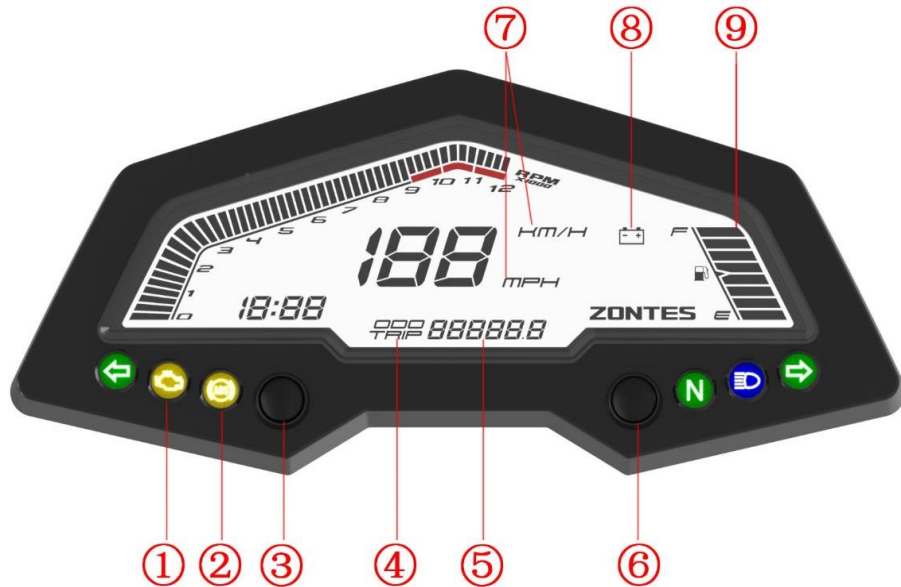

FIG.9 FRONT FORK COMPONENT	Instrument function description	CHK	
		ADJ	

Instrument parts function:

①EFI failure signal light; ②ABS anti-lock system signal light; ③MODE key; ④0D0 long odometer; ⑤TRIP short odometer; ⑥SET key; ⑦mile mark; ⑧battery low voltage prompt symbol; ⑨fuel level meter

(1) When the ignition switch turns from OFF to ON, the meter starts self-testing:

a. Replace the oil indicator light once

b. All content on the screen is displayed once and the normal content is displayed. The engine speed segment code is returned to the “0” scale position after scanning to the maximum scale.

(2) The EFI failure signal light① indicates that the EFI system is abnormal and continued driving may cause damage to the engine or transmission system. Please stop the motorcycle in a safe place and contact our designated aftermarket to inspect the EFI system of the motorcycle.

(3) The ABS anti-lock braking system signal light② will turn on when the key motorcycle self-check is turned on. When the motorcycle speed exceeds 5km/h, it will be automatically extinguished. Otherwise, it indicates that the ABS is faulty. Contact the company's designated after-sales store to inspect and repair the motorcycle.

(4) When the oil change indicator light is on, please stop the engine after stopping the motorcycle in a safe position, and check that the oil amount is sufficient. If it is not enough, it needs to be added as soon as possible; if it has been driven to a certain mileage, it needs to be replaced as soon as possible.

(5) Long press MODE key 3 in "0D0" mode to switch the speed between mph and km/h, and the odometer switches between mile and km.

(6) When the battery low voltage indication symbol flashes, it indicates that the battery voltage is lower than $11.5 \pm 0.25V$. Please contact our designated after-sales store to check, charge or replace the battery as soon as possible.

(7) Oil level table⑨ shows that the 8th stage indicates that the oil tank is full. When the oil level drops to approximately 1 litre, the oil mark flashes and the oil should be replenished as soon as possible.

(8) In the "0D0" mode, press and hold SET⑥ to enter the time mode. The MODE key is incremented by the hour; the SET key is pressed to enter the minute setting and flashes at the same time. The MODE competition is incremented by short minutes. Press and hold the SET key to complete the time setting. If the battery is disassembled or the loss of electricity clock is displayed from "12:00".

(9) 0D0 Long Odometer④ TRIP Short Odometer⑤

Long-short-range switching: In the TRIP mode, press the MODE button shortly to switch to “0D0”. In the 0D0 mode, press the MODE button shortly to switch to “TRIP” mode. Press and hold the SET button for a short distance to clear the zero. 0D0 Long mileage record total mileage cannot be cleared; TRIP can record single or multiple accumulated mileage can be cleared.

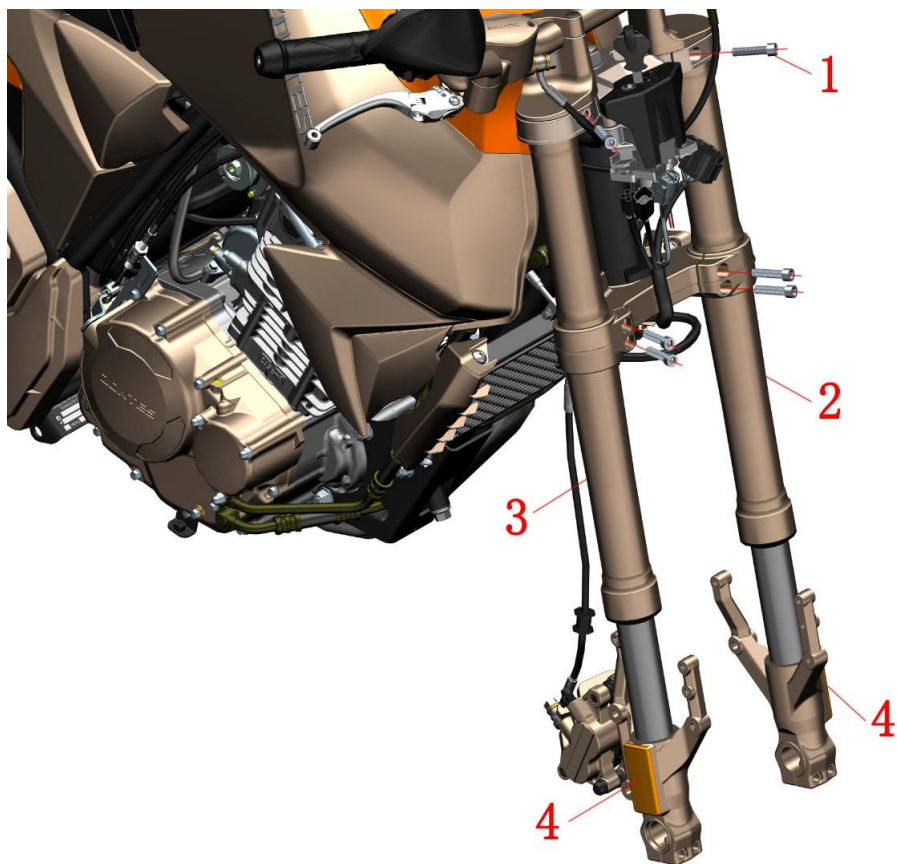

FIG.10 FRONT FORK COMPONENT		Front shock absorber		CHK	
NO.	PART NO.	PART NAME	QTY	CAUTION	
				ADJ	
1	1250205-023000	GB70.1 Hexagon M8×35 (environmental color zinc)	6		25N.m
2	1114100-007000	ZT250-R Front left shock absorber	1		WITH REFLECTOR
3	1114100-008000	ZT250-R Front right shock absorber	1		
4	1174100-001000	ZT250-S Reflector	2		for after-sale

PROCEDURE:

● Front left and right shock absorber

Remove the bolt(1) with the hexagonal tool, hold the shock absorber against the middle part in one hand, and insert a screwdriver into the slots of the upper and lower link plates to slightly expand the gap between the slots, and remove the left shock absorber(2) and the right shock absorber(3) respectively.

● Reflector

Reflectors are sold separately for sale (without replacement of shock absorption). The heat reflector can be used to move the heated reflector back and forth so that the adhesiveness of the double-sided adhesive is reduced after the heat is applied. The residual adhesive should be cleaned after the reflector is removed.

CAUTION:

- When using a flat-blade screwdriver to expand the slot gap between the upper and lower plate, do not apply excessive force to avoid damage.
- When removing the vibration, move it in the direction of axis, do not rotate or swing to prevent scratches on the surface.
- The motorcycle support should be fixed during disassembly to prevent accidents caused by incline.

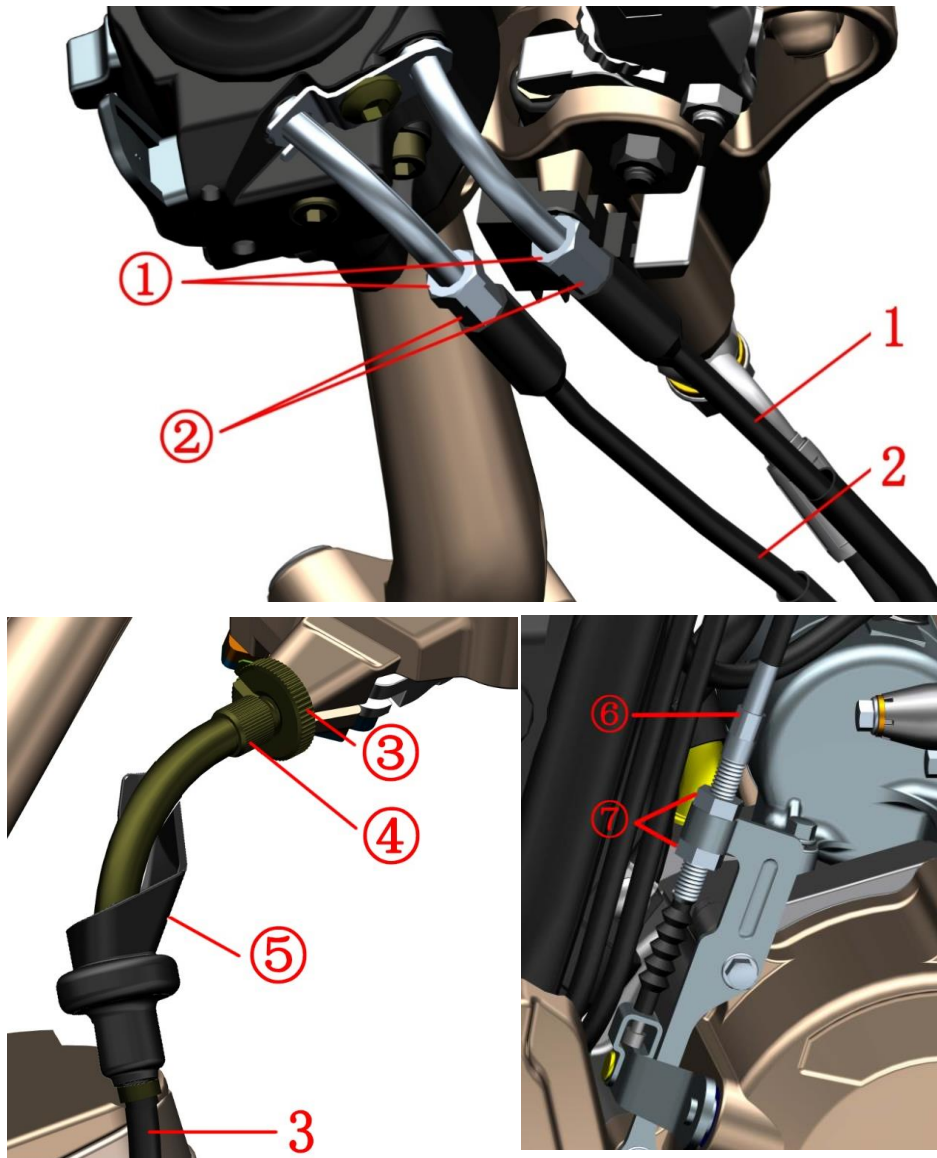

FIG.11 FRONT FORK COMPONENT		Throttle/clutch adjustment		CHK ADJ	CAUTION
NO.	PART NO.	PART NAME	QTY		
1	1154100-009000	ZT250-R Throttle refueling line (with elbow)	1		
2	1154100-010000	ZT250-R Throttle return line (with elbow)	1		
3	1154100-011000	ZT250-R Clutch line	1		

PROCEDURE:

● Throttle line

Use an open-end wrench to loosen the lock nut① on the throttle refueling line(1) or the return line(2), and turn the adjustment bolt② to adjust the clearance to 2 to 4 mm. After adjusting the lock nut①.

● Clutch line

Fine adjustment:

Lift the protective rubber sleeve⑤ on the clutch rocker arm to the elbow of the clutch line(3), loosen the bolt③ with pliers, rotate the adjustment bolt④, finally lock the bolt③, and then reset the dust jacket. Adjust the bolt④ and the rocker seat slot should be staggered position to prevent the cable from coming out.

Big adjustment:

If fine adjustment cannot be achieved, loosen bolt ⑦ with open-end wrench, rotate adjustment bolt⑥, and finally lock bolt ⑦ again.

CAUTION:

- The motorcycle support should be fixed during disassembly to prevent accidents caused by incline.
- Throttle line adjustment need to pay attention to the following:
 - After adjustment, ensure that the throttle can be reset automatically. It is forbidden to increase the engine idle speed due to adjustment of the line.
 - No engine idle increase in direction of rotation.
 - Check engine idle speed should be performed in the case of heat engine, should be at 1300~1500 rev / min.
- The clutch adjustment should be noted as follows:
 - Excessive free travel can cause wear and malfunction of the clutch and gearshift mechanism.
 - After adjustment, be sure to stagger the bolt, adjusting bolt and the slot on the rocker arm to a certain position to prevent the cable from coming out of the slot.

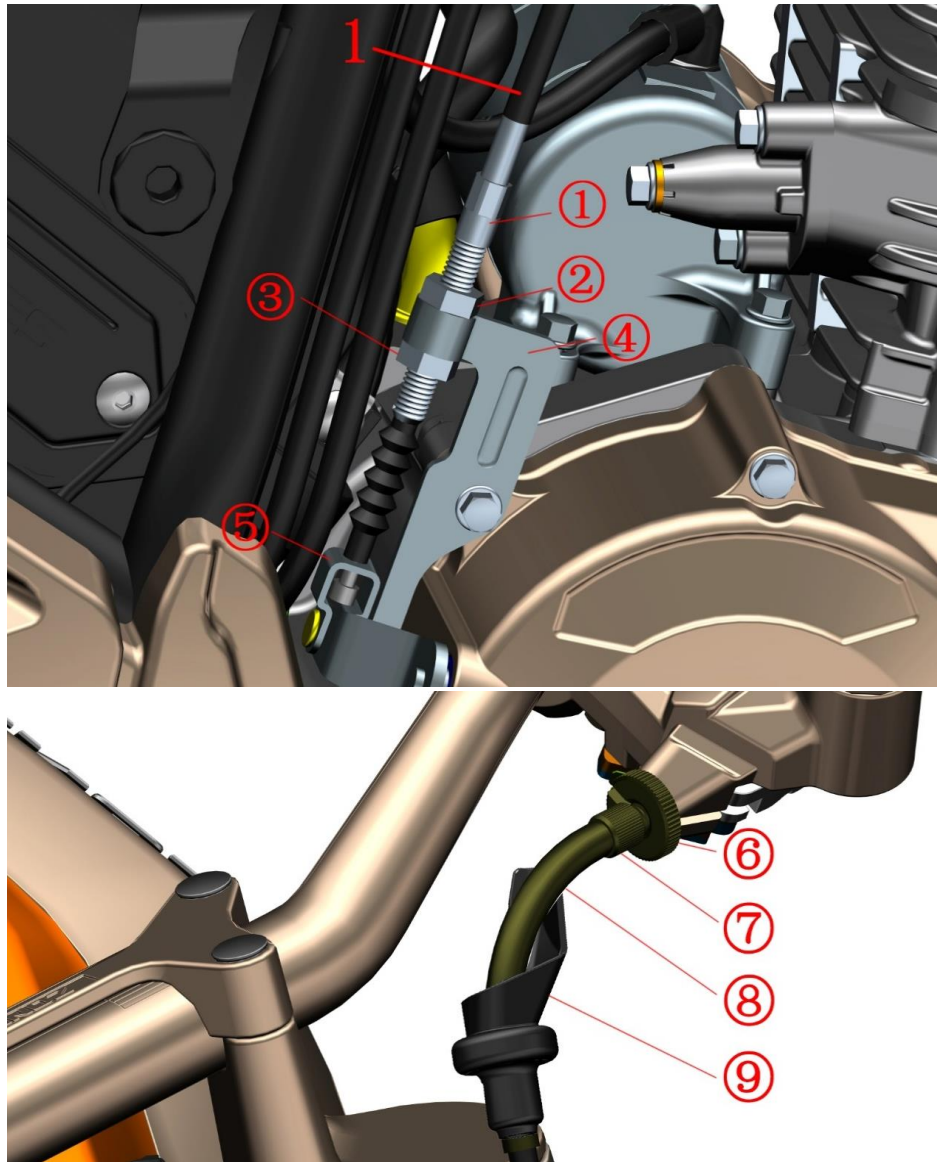

FIG.12 FRONT FORK COMPONENT		Replace the clutch line	CHK	
			ADJ	
NO.	PART NO.	PART NAME	QTY	CAUTION
1	1154100-011000	ZT250-R Clutch line	1	

PROCEDURE:

● Disassemble the clutch line

Use an open-end wrench to loosen the bolt② and bolt③; fix the adjusting screw①, rotate the bolt② up to the top of the thread of the adjusting screw, and screw the bolt③ to the bottom to completely separate from the thread. Separate the clutch wire core connector from the bracket⑤, close the bolt③ to the black sheath with one hand, and remove the adjustment screw① from the bracket④ with one hand.

First, the protective rubber sleeve⑨ is retracted to the elbow⑧ and the nut⑥ is loosened with the pliers; the nut⑥ and the adjusting screw⑦ are rotated to the same position as the groove on the rocker arm, and the cable is pulled from the rocker arm seat. Finally remove it.

Remove the clutch line.

Remove the protective sleeve⑨ from the clutch cable (1).

● Install the clutch

Put protective rubber sleeve⑨ into clutch elbow

After inserting the clutch cable joint into the rocker arm, screw the nut⑥ and the adjusting screw⑦ to the groove on the rocker arm.

Assemble the clutch cable into place according to the original alignment.

Rotate the nut② up to the top of the thread of the adjusting screw, and screw the nut③ to the bottom to completely separate from the thread.

Take the nut③ close to the black sheath with one hand and insert the adjustment screw① into the bracket④ with the other hand.

Insert the clutch core connector into the hole of the bracket⑤.

Initially position the nut② first, adjust the free stroke adjustment in the clutch cable adjustment, and then lock the nut③.

Finally, reset the protective rubber sleeve⑨.

CAUTION:

- The motorcycle support should be fixed during disassembly to prevent accidents caused by incline.
- Before replacing the clutch line, it is necessary to disassemble the seat cushion, fuel tank, liner, side cover, etc.

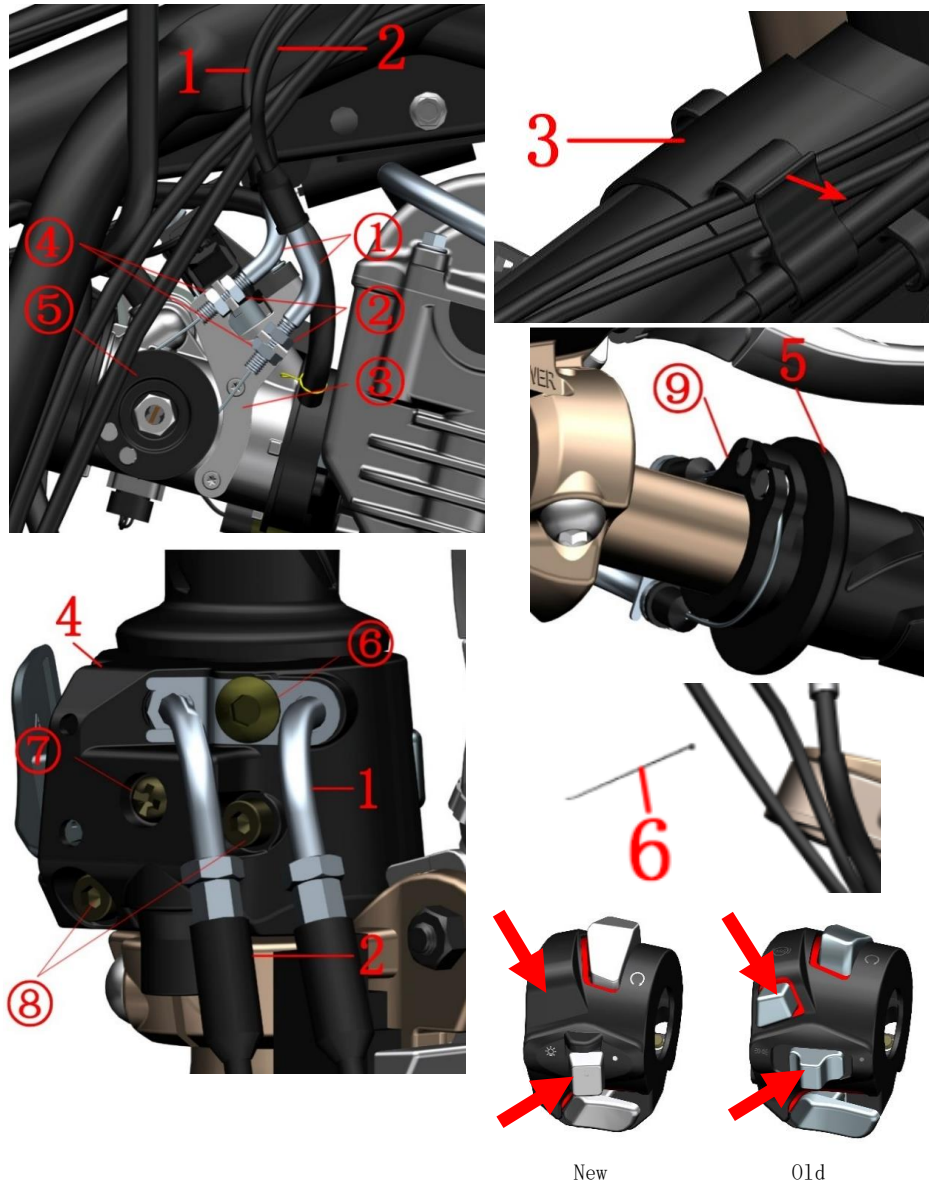

FIG.13 FRONT FORK COMPONENT		Replace the throttle line	CHK	⚠
			ADJ	
NO.	PART NO.	PART NAME	QTY	CAUTION
1	1154100-009000	ZT250-R Throttle refueling line (with elbow)	1	
2	1154100-010000	ZT250-R Throttle return line (with elbow)	1	
3	1224100-049000	ZT250-R Line clamp	1	
4	1184100-112000	ZT250-R Right hand switch (without positioning pin)	1	out of stock
	1184100-126000	ZT250-R Right hand switch (without ABS button/new)		
5	1244100-140000	ZT250-R right handle bar rubber sleeve(after-sale)	1	
6	1224100-051000	0 level flame retardant tie (black 2.5×100)	1	

PROCEDURE:

● Disassemble the throttle line

Use an open-end wrench to turn the nut② of the throttle refueling line (1) or the oil return line (2) upside down, turn the nut④ downwards and out of the bend 1; rotate the turntable on the throttle valve clockwise, and turn the cylindrical joint of the fuel line from the turntable Remove; then move the elbow upwards over the bracket③ on the throttle and pull outwards to separate the core from the bracket. After removing the fuel line, pull the return line core downwards and separate the joint from the turntable, and then move the elbow up and separate from the bracket.

Use pliers to open the card on the line clamp(3) slightly in the direction of the arrow, remove the throttle cable from the slot, and cut the cable tie(6).

Remove the bolts⑥ and⑧ with the hexagonal tool.

Hold the right hand switch(4) with your hand and remove the bolt⑦ with a cross screwdriver. Turn the handlebars on and off.

Remove the throttle line from the right hand and remove the rubber sleeve(5) from the core turntable⑨ and remove it from the cable hole in the lower part of the switch.

● Install the throttle line

First pass the throttle line into the line hole in the lower part of the switch, and pay attention to distinguish between the fuel line and the return line. Fit the cylindrical connector of the throttle cable into the turntable⑨ on the right hand gripper(5). Return the oil return line card to the limit slot provided on the refueling line. Use a hexagonal tool to lock the bolt⑥ to a torque of 8-10 Nm. After aligning the upper and lower holes of the switch, it is advisable to screw the bolt 8 a few times to prevent it from falling out. Then, after observing the right hand, align the positioning holes and the direction of the lower part of the switch(4) and fix the bolt⑦ after locking. Finally, tighten the bolt⑧ and tie the tie(6). Cut off the excess.

Push the throttle cable into the cable clamp slot.

Use an open hand to turn the nut② of the throttle refueling line(1) or the return line(2) up and down, and turn the nut④ downwards to the bend①. Put the oil return line into the bracket③, and then put the joint onto the turntable⑤. Put the oil line into the bracket③, then turn the turntable⑤ to a certain angle.

Adjust the gap to adjust the throttle line clearance. Lock nuts② and④.

CAUTION:

- The motorcycle support should be fixed during disassembly to prevent accidents caused by incline.
- Before replacing the throttle line, you must first remove the seat cushion, fuel tank, liner, side cover, etc.

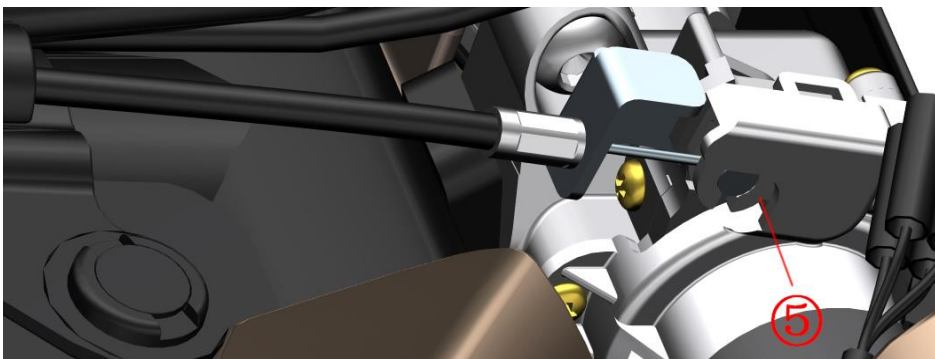
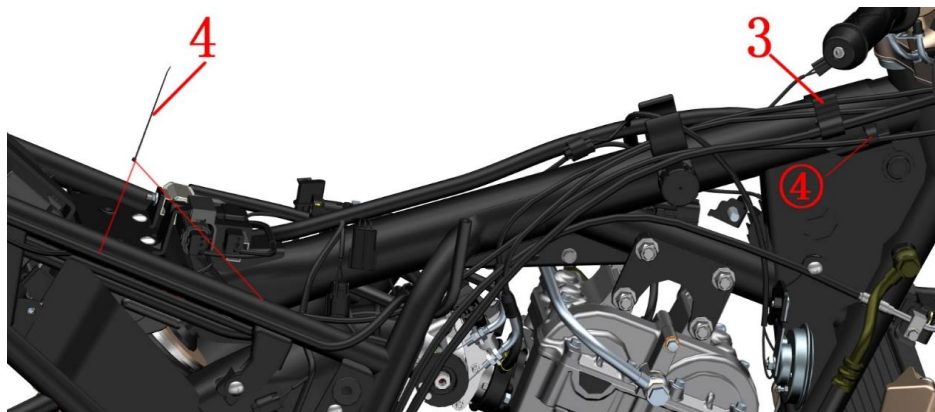
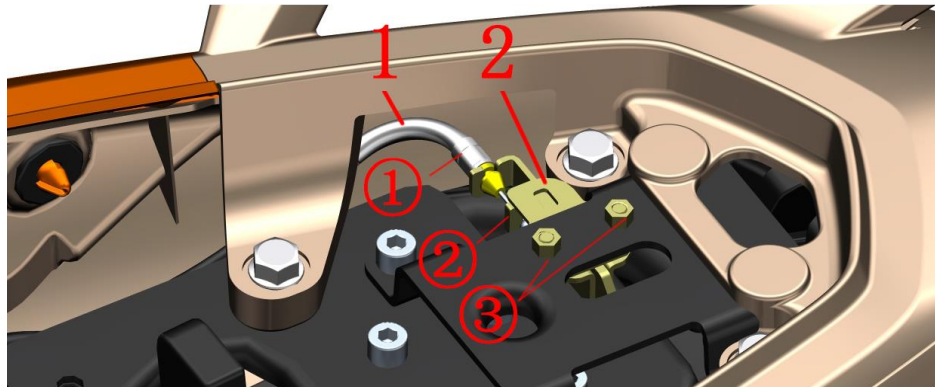

FIG.14 FRONT FORK COMPONENT		Replace the cushion cable		CHK	
				ADJ	
NO.	PART NO.	PART NAME		QTY	CAUTION
1	1154100-008000	ZT250-R Seat cushion lock cable		1	
2	1274100-023000	ZT250-S Cushion lock		1	
3	1224100-049000	ZT250-R Line clamp		1	
4	1224100-051000	0 level flame retardant tie (black 2.5×100)		2	

PROCEDURE:

● Remove cushion cable

Shearing straps (4).

Pull the elbow① of the seat cushion cable(1) up and out of the bracket slot of the seat cushion lock(2).

Push down the bracket② of the seat cushion lock(2) to pull the cable core out of the slot of the seat pad lock bracket②.

Open the hub clamp(3) slightly with pliers and remove the cable; note the strength to prevent damage to the hub clip.

Use pliers to turn the cable core in the direction of the arrow, align it with the slot on the key tongue⑤, pull it down, and take care to prevent damage to the cable.

● Cushion cable

Assembling should start from the front of the car and assemble it backwards. Finally, the straps cut off the excess part.

● Cushion lock

Use a sleeve to remove the nut③ and remove the seat lock.

CAUTION:

- The motorcycle support should be fixed during disassembly to prevent accidents caused by incline.
- Before replacing the seat cushion cable, it is necessary to disassemble the seat cushion, fuel tank, liner, side cover, etc.
- Pay attention to prevent damage to the core.

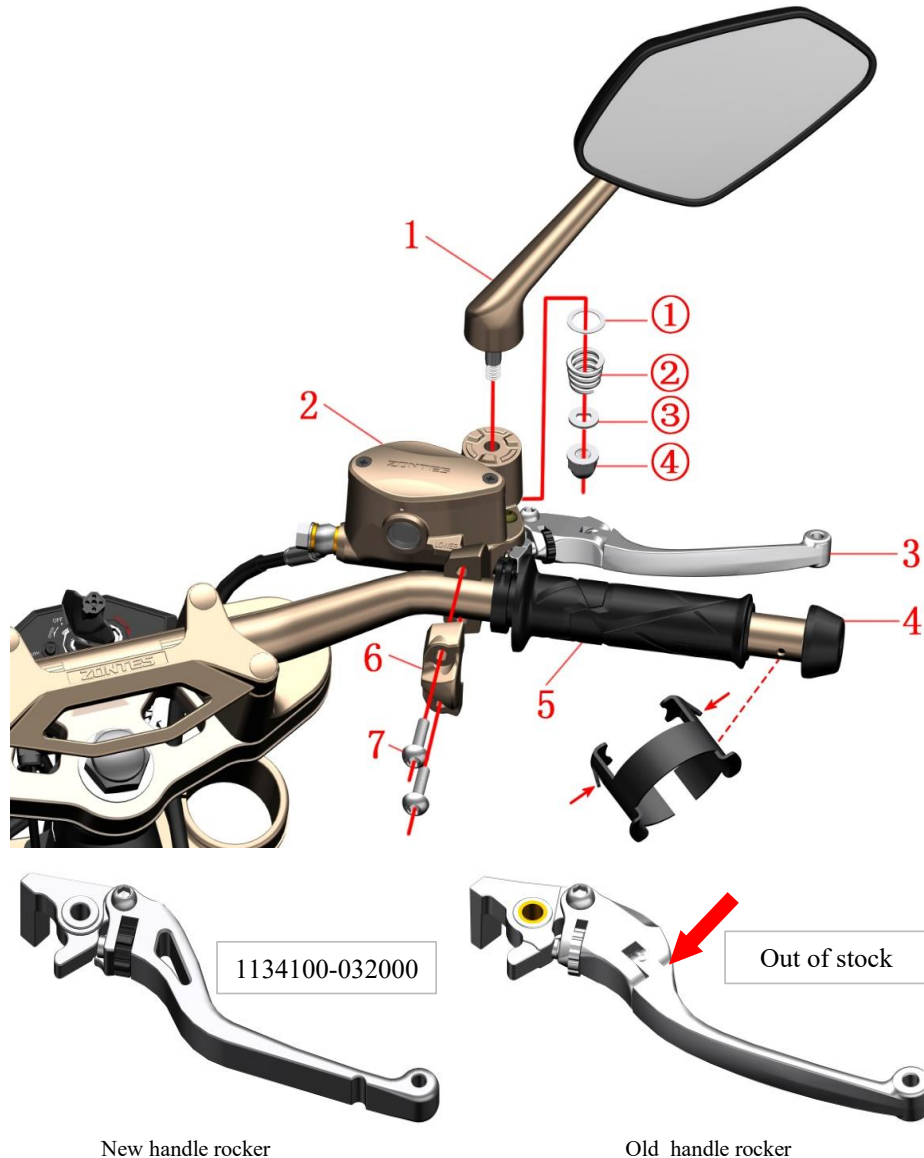

FIG.15 FRONT FORK COMPONENT		Right handle assembly		CHK ADJ	CAUTION
NO.	PART NO.	PART NAME	QTY		
1	1194100-002000	ZT250-S Right rearview mirror	1		
2	1100300-044000	Front disc brake main pump assembly(without handle)	1		
3	1134100-032000	ZT250-R Right handle rocker arm (Machine)	1		
4	1134200-023000	ZT250-R Balancing block	1		
5	1244100-140000	ZT250-R right handle bar rubber sleeve(after-sale)	1		
6	1134100-019000	ZT250-R Right handle half cover	1		
7	1251100-121093	Non-standard bolt M6×25 (green color)	2		

PROCEDURE:

●Rearview mirror

Hold the mirror stem in one hand, remove the nut④ with a sleeve, and remove the small pad③, the spring② and the large pad①. Remove the rearview mirror from the front brake master pump.

●Right handle to put rubber sleeve, balance block

Push the rubber sleeve(5) with the right hand to push forward to expose the upper balance block fixing hole; use the tool to press the convex parts at both ends of the elastic block on the balance block and pull out the balance block assembly(4), then turn the right handle. Remove the rubber sleeve(5).

●Right handle half cover

Fix the front disc brake main pump(2) with one hand, and remove the bolt(7) with the hexagonal tool and remove the half cover(6).

CAUTION:

- The motorcycle should be fixed after horizontal support.
- Periodically check that the fluid level of the brake fluid is between 3/4 of the observation window.
- Do not flush the cup directly with high pressure water.
- When assembling the balance block, align the protruding parts at both ends of the shrapnel with the fixing holes on the handle and insert the direction into the holes.
- The small spacer of the rear view mirror anti-rotation limit slot needs to be aligned with the slot on the mirror bar bolt.
- The right hand refers to the switch to replace the throttle line.
- The joint between the front disc brake main pump and the half cover should be aligned with the right hand to match the triangle on the switch.
- The old rocker assembly has been discontinued and need to buy this new rockdr arm replacement.

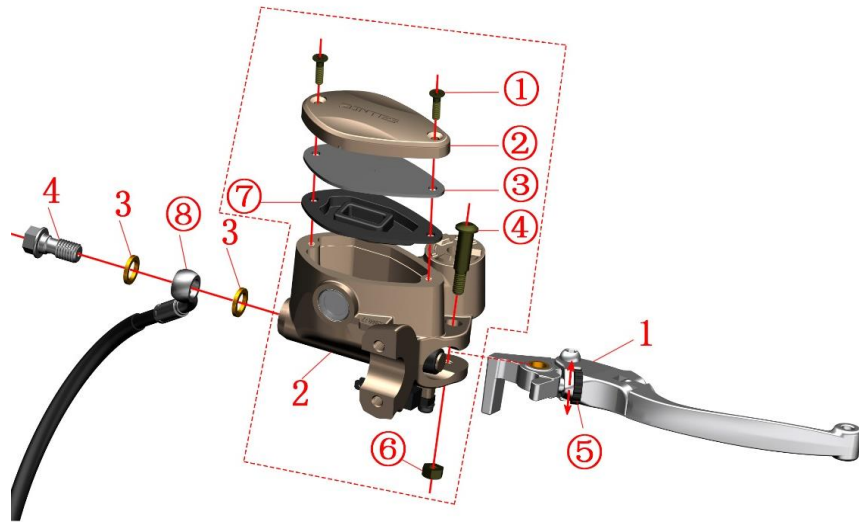
**PROCEDURE:**● **Front disc brake main pump**

Fix the front disc brake main pump and remove the bolt(4) and copper pad(3) with the sleeve. Do not disassemble it if it does not need to be replaced. Always replace the tubing connector 8 at a high level to prevent air from entering the tubing and cause brake failure. Also clean oil should be removed to prevent dripping onto parts such as covers or mufflers. Be sure to continuously hold the rocker arms after replacement(1) Tap the disc brake main pump(2) to remove a small amount of gas entering the brake oil circuit and confirm that the brakes return to normal.

● **Rocker**

Rotate the adjusting nut(5) to adjust the distance between the rocker arm and the handle rubber sleeve to adapt to the different driver's feeling.

If you need to replace the rocker, fix the bolt(4) with a hexagon socket tool and remove the nut(6) with a socket or box wrench. Remove the bolt(4) and remove the rocker(1).

● **Add brake fluid**

Before driving the motorcycle, check whether the brake fluid level is above the "LOWER" marking. If not, check the brake disc or brake disc for wear and whether there is any oil leakage or oil leakage in the brake system. Abnormalities are excluded, then it needs to add brake fluid.

The brake fluid can only be added after the motorcycle is fixed in the horizontal position.

Use a cross screwdriver to remove the bolt(1), remove the top cover(2), cover plate (3), and seal gasket (7).

Add DOT4 brake fluid to front disc brake main pump transparent observation window 3/4.

Be sure to clean the foreign body before reassembling.

FIG.16 FRONT FORK COMPONENT		Add brake fluid, rocker adjustment	CHK	
			ADJ	
NO.	PART NO.	PART NAME	QTY	CAUTION
1	1134100-032000	ZT250-R Right handle rocker arm (Machine)	1	
2	1100300-044000	ZT125T front disc brake main pump assembly (without	1	
3	1251513-013000	Disc brake copper washer φ15×φ10.2×1.5	2	
4	1251100-112000	Disc brake oil pipe bolt M10×1-22	1	

CAUTION:

- The motorcycle should be fixed after horizontal support.
- Periodically check that the fluid level of the brake fluid is at 3/4 of the observation window.
- If the liquid level is under "LOWER", check the brake disc wear and the brake system for leaks.
- If the brake fluid is swallowed, contact the poison control center or the hospital immediately; if you get into your eyes, seek medical attention immediately after flushing with clean water.
- Keep brake fluid away from children and pets.
- Do not flush the cup directly with high pressure water.
- Do not mix water, dust, impurities, and silicic acid or petroleum-based liquids, otherwise it will cause serious damage to the brake system.
- The old rocker assembly has been discontinued and need to buy this new rockdr arm replacement.



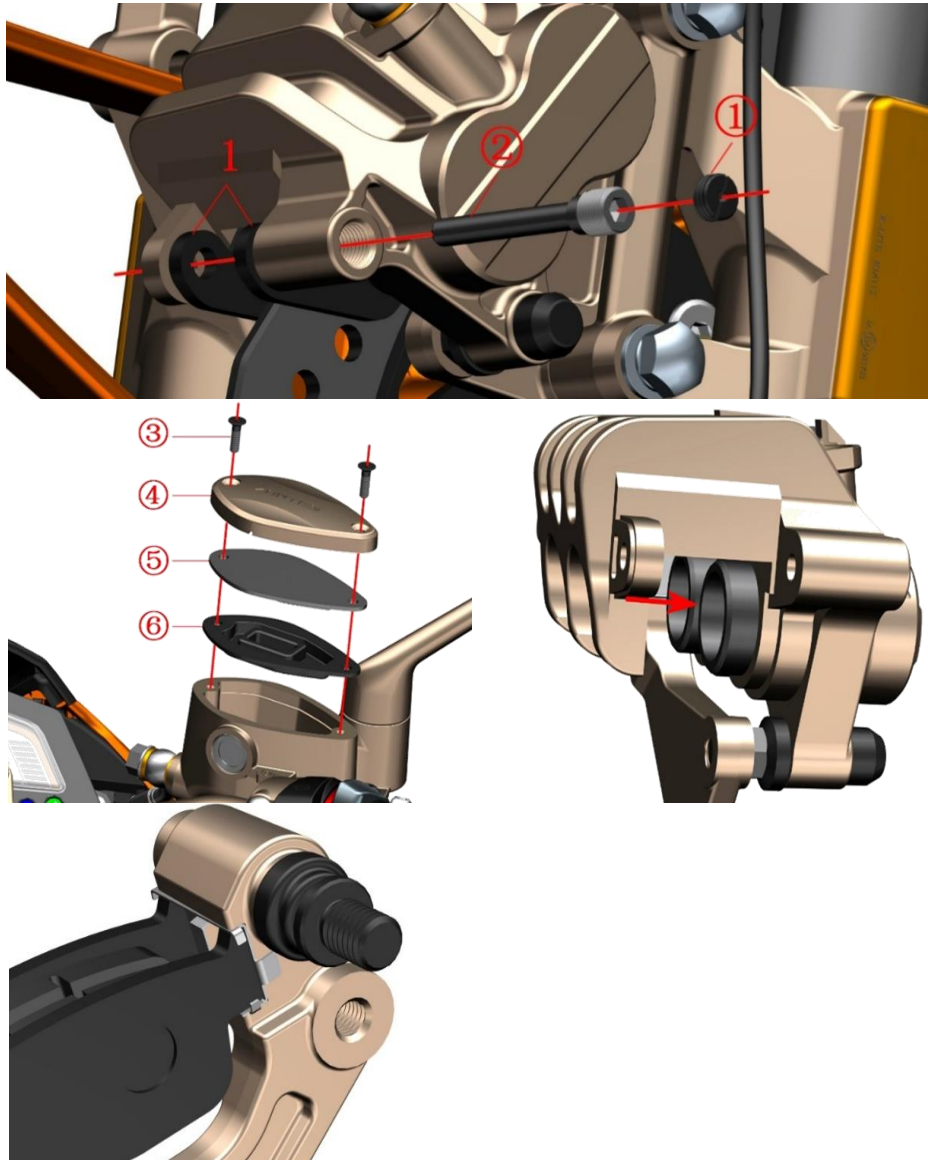

FIG.17 FRONT FORK COMPONENT		Replace the front brake shoe	CHK	
			ADJ	
NO.	PART NO.	PART NAME	QTY	CAUTION
1	1100100-091000	ZT250-S Front Disc brake shoe (H10)	1	

PROCEDURE:

- Replace the front brake shoe
 - Use a screwdriver to remove the nut①.
 - Remove pin② with hexagonal tool.
 - Remove the brake shoe (1).
 - Clean out foreign matter such as dust on the outer edge of the piston.
 - Use a cross screwdriver to remove the bolt③ on the front brake main pump assembly, remove the top cover④, cover plate⑤, and seal gasket⑥.
 - Push the piston in the direction of the arrow.
 - Restore the front disc brake main pump assembly, it must be accurately assembled in place.
 - Put a new brake shoe, be sure to place the brake shoe close to the card slot, as shown on the left.
 - Lock the pin② with a hexagonal tool.
 - Use a flathead screwdriver to lock the nut①.
 - Repeatedly holding the brake handle until braking force is restored.

CAUTION:

- The motorcycle support should be fixed before operation
- Check the brake discs and brake discs regularly for wear. Regularly check if the brake fluid level in the front window of the main brake disc is 3/4.
- It is strictly prohibited to disassemble the oil pipe bolts and gas discharge nozzle bolts when replacing the brake shoes to prevent air from entering the pipeline and causing brake failure.
- Do not shake the front after removing the front brake oil cup lid to prevent the brake fluid from overflowing.
- After replacing the brake shoes, the new brake shoes should be operated for about 300 km to fully run in order to achieve the best braking effect. Be careful to allow enough braking distance during running-in.
- It is recommended to replace brake shoes in pairs with qualified maintenance units.

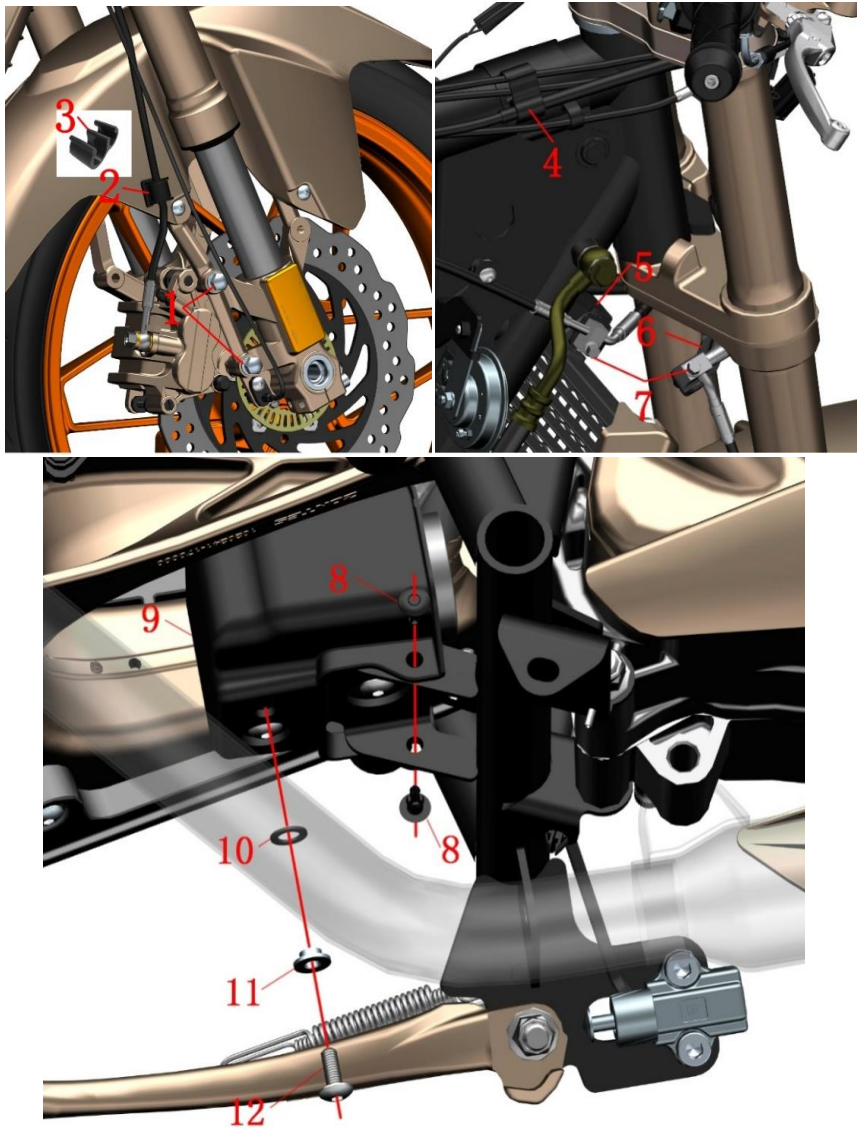

FIG.18 FRONT FORK COMPONENT		ABS braking system-1	CHK	CAUTION
NO.	PART NO.	PART NAME	ADJ	
1	1251100-080094	Non-standard bolt M8×37 (environmental color zinc)	2	
2	1274100-014000	ZT250-S Front disc brake pipe clamp	1	
3	1224100-044000	Wheel speed sensor clamp	2	
4	1224100-049000	ZT250-R Line clamp	1	
5	1274100-079000	ZT250-R Front disc brake tube bracket No.2	1	
6	1274100-078000	ZT250-R Front disc brake tube bracket No.1	1	
7	1251100-061093	M6×22 Hex flange threaded bolt (8.8 grades/environe	2	
8	1224100-089000	ZT250-S Expansion nail(5 pcs/after-sale)	2	
9	1224100-047000	ZT250-R ABS hydraulic control init cover	1	
10	1241200-124021	flanging bushing buffer rubber (φ8.5×φ14×1)(5 pcs/aft	1	
11	1274100-155095	Flanged bushing φ6.2×φ8.4×3.5+φ14×1.5(5 pcs/after-	1	
12	1251100-102000	Non-standard bolt M6×16 (304 stainless steel)	1	

PROCEDURE:

●Front disc brake pump body

Refer to the previous steps to remove the "front wheel speed sensor assembly" and remove the bolt(1), the lower hose clamp(2), and the sensor clamp(3).

●Disc Bracket

Remove bolts(7) without removing brackets(5) and(6).

If you need to replace the bracket(5) with reference to the step of "heat sink 1" in the heat dissipation system, bracket(6) refers to the step of "head assembly 1" above.

●ABS protection cover

Refer to the steps in "Rear Flange Assembly" in the rear and rear trim assembly and remove the expansion screw(8), bolt(12), bushing(11), pad(10) and protective cover(9).

CAUTION:

●Need to remove the seat cushion, fuel tank and liner, side cover, lower shroud, hood component, muffler in advance.

●Do not disassemble the muffler and engine until they have completely cooled down.

●The motorcycle should be fixed horizontally and then disassembled.

●Because the ABS control system adopts the dry ABS control unit (ie, the ABS control unit itself does not have brake fluid), it must obtain our company's authorization code and adopt professional vacuum equipment to fill the ABS system with disc brake oil. If there is no professional equipment, it is forbidden to dismantle the whole system without authorization, otherwise it may cause the brake to fail, resulting in accidental injury.

●Front and rear disc brakes The main pump oil cup does not need professional equipment and authorization code to add brake fluid, but need to prevent air from entering the piping.

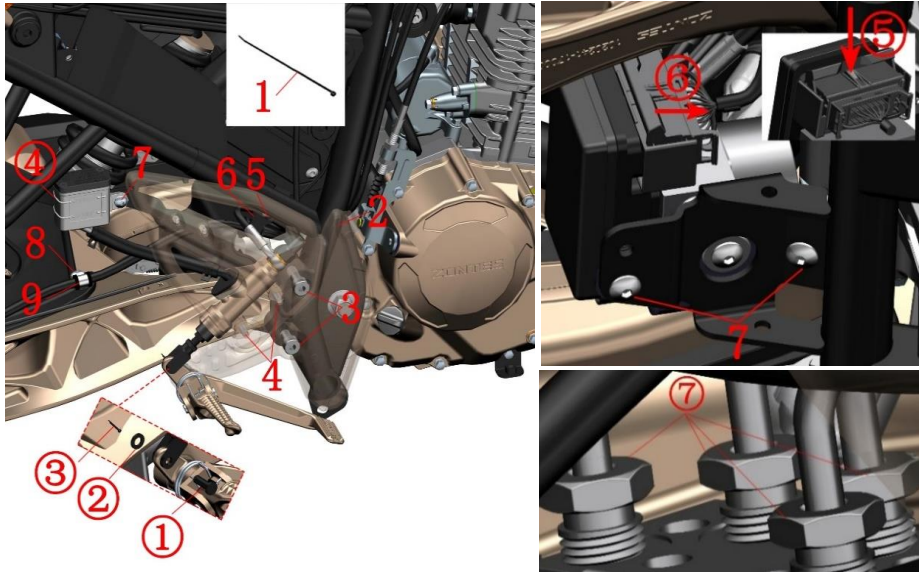

FIG.19 FRONT FORK COMPONENT		ABS braking system-2	CHK	⚠
			ADJ	
NO.	PART NO.	PART NAME	QTY	CAUTION
1	1226000-218000	Grade 0 flame retardant tie (black 3.6×295)(5 pcs/after-	3	
2	1274100-036000	ZT250-S Right foot support	1	
3	1251100-083094	Non-standard bolt M10×1.5×50 (Dacromet)	2	
4	1251100-121093	Non-standard bolt M6×25 (green color)	2	
5	1251100-101000	Non-standard bolt M6×12 (304 stainless steel)	1	
6	1274100-076000	ZT250-R Rear disc brake oil pipe clamp (steel)	1	
7	1251100-102000	Non-standard bolt M6×16 (304 stainless steel)	3	
8	1251112-001093	M6×16 Hexagon flange bolt (color zinc)	1	
9	1274100-088000	Rear disc brake oil pipe clamp (steel / rubber pad)	1	

PROCEDURE:

●Foot support assembly

Remove the split pin③, washer②, and pin① at the connection between the rear brake main pump and the brake pedal. Referring to the steps of "Right foot support assembly-1" in the pedal and shift lever assembly, remove the bolt(3), the right foot support(2), and the bolt(4).

●ABS brake system parts

Remove the bolt (7) at the footrest bracket and remove the rear brake main pump oil cup④.

Remove the bolt(5) with the hexagonal tool and pull the tubing out of the bracket(6).

Remove the bolt(8) at the rear inner mud plate with the hexagonal tool and pull the tubing from the bracket(9).

●ABS control unit assembly

Remove the bolts(7) at the joint between the ABS control unit and the frame, and cut the tie(1).

Press the limit tab⑤ on the cable connector and push the lever⑥ in the direction of the arrow to pull out the cable connector.

Pull out the ABS control unit assembly and place the oil pan underneath. First loosen the cross bolt on the upper lid of the front disc brake oil cup, and then loosen the nut 7 with an open wrench to empty the brake fluid in the tubing. Finally clean the oil with a clean non-woven cloth.

CAUTION:

●Need to remove the seat cushion, fuel tank and liner, side cover, lower shroud, hood component, muffler in advance.

●Do not disassemble the muffler and engine until they are completely cooled.

●The motorcycle should be fixed horizontally and then disassembled.

●Because the ABS control system adopts the dry ABS control unit (ie, the ABS control unit itself does not have brake fluid), it is necessary to obtain our company's authorization code and use of professional vacuum equipment to fill the ABS system with disc brake oil. If there is no professional equipment, it is forbidden to dismantle the whole system without authorization, otherwise it may cause the brake to fail, resulting in accidental injury.

●Front and rear disc brakes The main pump oil cup does not need professional equipment and authorization code to add brake fluid, but need to prevent air from entering the piping.

●The torque standard of nut⑦ is 18N.m.

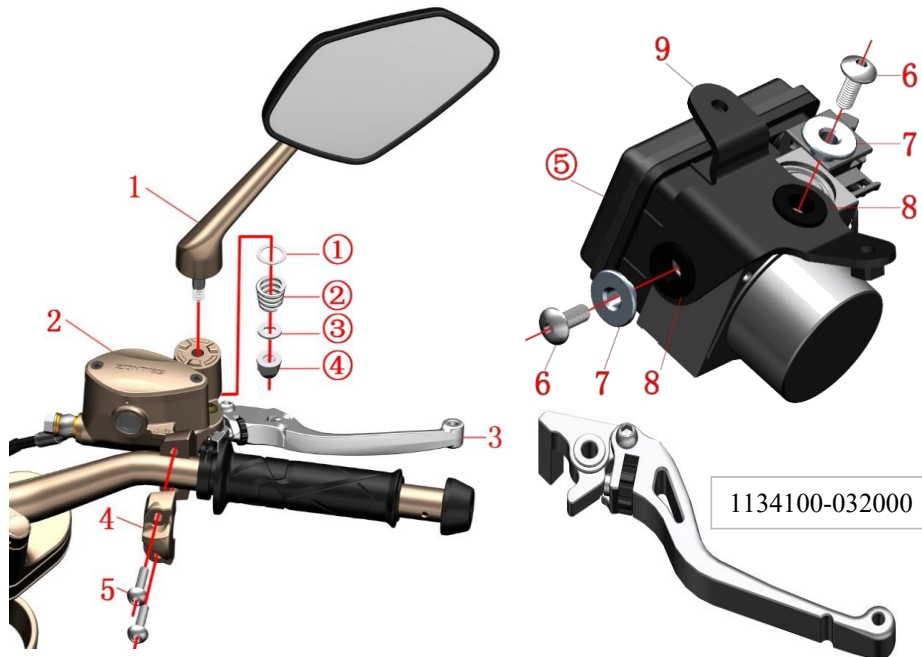
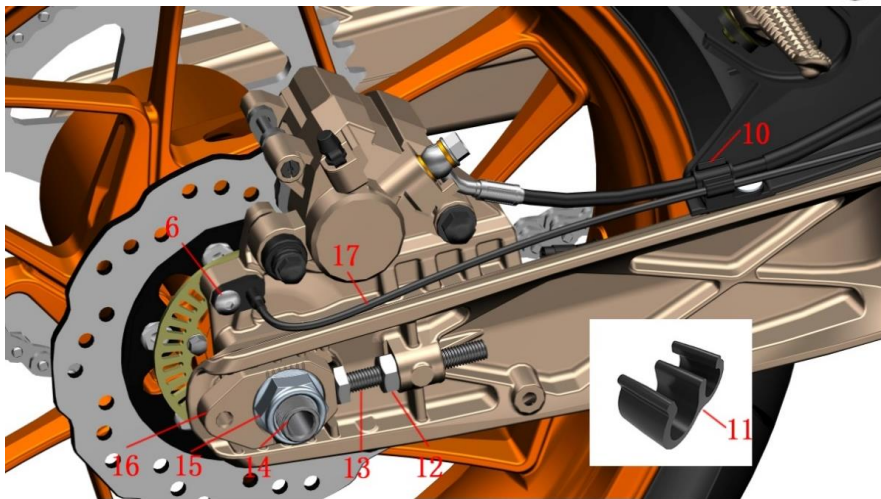

FIG.20 FRONT FORK COMPONENT		ABS braking system-3		CHK	⚠
				ADJ	
NO.	PART NO.	PART NAME	QTY	CAUTION	
1	1194100-002000	ZT250-S Right rearview mirror	1		
2	1100300-044000	ZT125T Front disc brake main pump assembly (without	1		
3	1134100-032000	ZT250-R Right handle rocker arm (Machine)	1		
4	1134100-019000	ZT250-R Right handle half cover	1		
5	1251100-121093	Non-standard bolt M6×25 (environmental color)	2		
6	1251100-102000	Non-standard bolt M6×16 (304 stainless steel)	3		
7	1274101-015000	ZT250-S flanging sleeve(φ6.4×φ9×6+φ20×2)(5 pcs/af	2		
8	1244100-137000	ZT250-S Flanging bushing buffer(5 pcs/after-sale)	2		
9	4024100-020000	ZT250-R ABS mounting bracket	1		
10	1224200-003000	ZT310-Z Rear disc brake oil clamp	1		
11	1224100-044000	Wheel speed sensor clamp	3		
12	1251300-050000	ZT310-Z Chain adjuster nut M10 (304 stainless steel)	1		
13	1251100-105000	ZT310-Z Chain adjuster bolt M10×70 (304 stainless ste	1		
14	1094100-032000	ZT250-R Rear wheel hollow shaft	1		
15	1251300-067000	ZT250-R Rear wheel hollow shaft nut	1	110N.m	
16	1274100-072000	ZT310 Right adjuster	1		
17	1184200-045000	DF30 wheel speed sensor	1		



PROCEDURE:

● Front disc brake main pump assembly

Referring to the steps of "Right Handle Assembly" and "Adding Brake Fluid, Rocker Adjustment", remove the rearview mirror(1), the front brake main pump(2), the rocker arm(3), the half cover(4), and the bolt(5). Remove the tube.

● ABS mounting bracket assembly

Remove the bolt(6), bushing(7), bracket(9) and ABS control unit⑤ with the hexagonal tool; remove the buffer(8) from the bracket.

● ABS rear assembly

Remove the clip(11); pull the tubing from the clip(10); remove the bolt(6) with the hexagonal tool and pull the wheel speed sensor(17) out from the rear caliper.

Refer to the steps of the "rear wheel assembly" in the rear and rear trim assembly. Turn the nut(12) and bolt(13) forward and remove the hollow shaft nut(15). Hold the rear wheel assembly with one hand and tap the hollow end of the hollow shaft(14) with a rubber hammer to retract the hollow shaft until the caliper can be removed.

CAUTION:

● Because of the special nature of the brake system, it is not recommended to dismantle and repair it by yourself; be sure to give it to a qualified repair center.

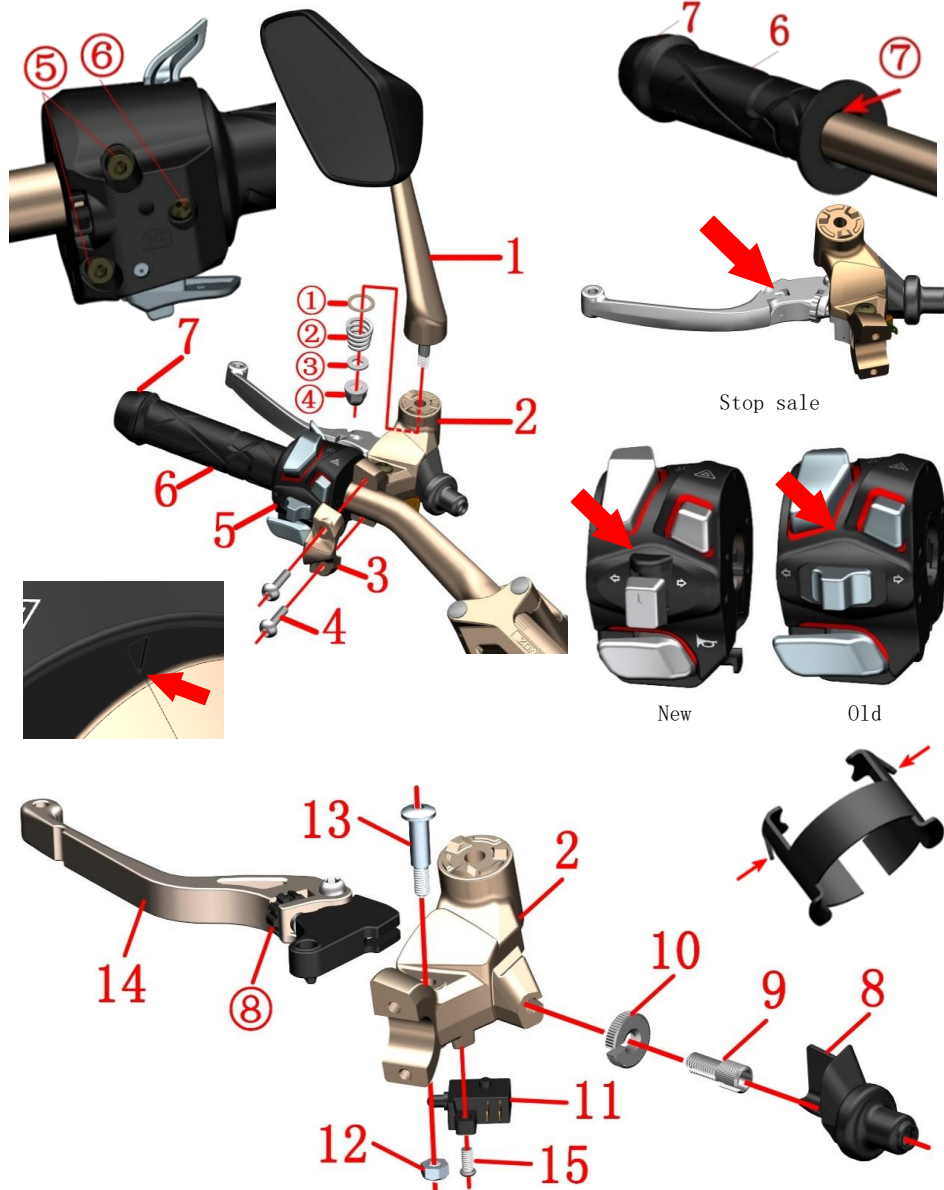

FIG.21 FRONT FORK COMPONENT		Left handle assembly, rocker adjustment	CHK	⚠
			ADJ	
NO.	PART NO.	PART NAME	QTY	CAUTION
1	1194100-001000	ZT250-S Left rearview mirror	1	
2	1134100-034000	Left handle rocker arm(without switch/adjusting screw)	1	
3	1134100-017000	ZT250-R Left handle half cover	1	
4	1251100-121093	Non-standard bolt M6×25 (environmental color)	2	
5	1184100-127000	ZT250-R left hand switch (without ABS button/new)	1	
6	1244100-139000	ZT250-R left hand rubber sleeve(after-sale)	1	
7	1134200-023000	ZT250-R Balancing block	1	
8	1244100-096000	ZT250-R protective rubber sleeve	1	
9	1251100-249000	ZT250-R clutch rocker arm adjusting screw	1	
10	1251300-079000	T250-R clutch rocker arm lock nut	1	
11	1184200-170000	ZT310-V Clutch switch	1	
12	1251300-073000	GB/T6185 nut M6	1	
13	1251100-198000	Non-standard bolt M6×13-φ8×20	1	
14	1134100-031000	ZT250-R Left handle rocker (Machine)	1	
15	1250201-039000	GB818 cross recessed pan head screw M4×12 (color zinc)	1	

PROCEDURE:

● Left rearview mirror

Hold the mirror stem in one hand, remove the nut④ with a sleeve, and remove the small pad③, the spring② and the large pad①. Remove the left rearview mirror from the left arm(1).

● Left handle rocker arm assembly, half cover

Fix the left handle rocker arm assembly(2) with one hand, remove the bolt(4) with the hexagonal tool, and remove the half cover(3). Pull out the left handle and insert the switch wire, remove the bolt⑤ with the hexagonal tool, and then remove the bolt⑥ with a cross screwdriver and remove the switch(5).

● Left rubber sleeve and balance block assembly

Use a dust blower to inject the left sleeve between the rubber sleeve(6) and the direction handle with the arrows as indicated by arrow⑦ and move the rubber sleeve inwards until the counterweight positioning hole is exposed. Press the convex parts at the two ends of the weight on the balance weight inward and pull out the balance weight assembly at the same time(7). Use a dust blower to inject the left sleeve of the rubber sleeve(6) and the direction of the handle with the arrows as shown in Figure⑦ and move it outward to remove the rubber sleeve(6).

● Replace the left handle rocker arm, clutch switch

Take off the rubber sleeve(8), then remove the adjusting screw(9) and the lock nut (10).

Fix the bolt(13) then remove the nut(12), remove the bolt and remove the left-hand rocker arm(14). First remove the clutch switch plug, then use a cross screwdriver to remove the bolt(15), remove the clutch switch(11). Rotate the adjusting nut⑧ to adjust the distance between the rocker arm and the left handle to adjust the rubber sleeve to adapt to different driver's hand feeling.

CAUTION:

● Old handlebar switch can be replaced as new models.

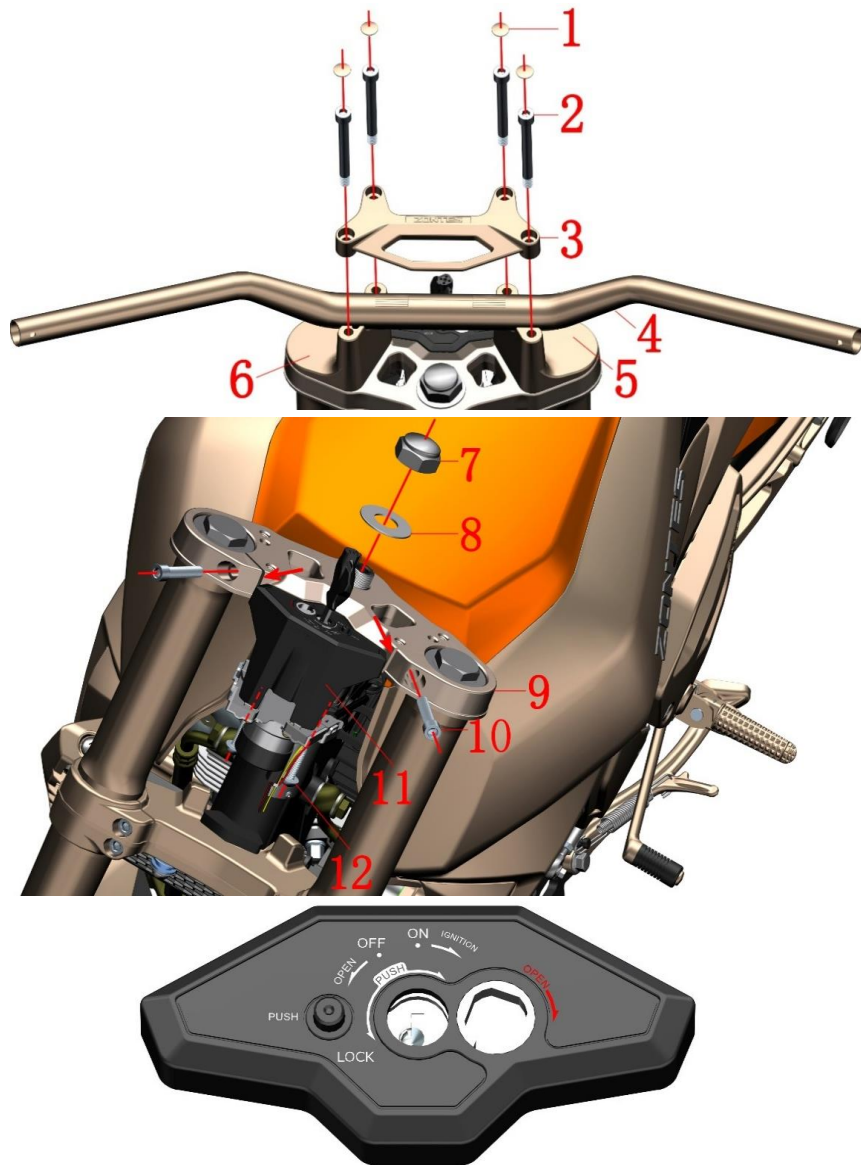

FIG.22 FRONT FORK COMPONENT		Direction handle, upper plate assembly	CHK	⚠
			ADJ	
NO.	PART NO.	PART NAME	QTY	CAUTION
1	1224100-094051	ZT250-S M8 bolt decorative buckle (titanium gold/WX	4	
2	1251100-046000	Non-standard bolt M8×90 (environmental color zinc)	4	
3	1134100-009000	ZT250-S Handlebar press block	1	
4	1134100-030000	ZT250-R Handlebar (thread positioning)	1	
5	1134100-010000	ZT250-S Handlebar right pad block	1	
6	1134100-011000	ZT250-S Handlebar left pad block	1	
7	1251300-045000	ZT250-S Upper plate decorative nut (chrome)	1	
8	1251500-050000	ZT250-S Upper plate gasket φ18.5×φ39×1 (chrome)	1	
9	1134100-020000	ZT250-S Upper plate (self-improvement)	1	
10	1250205-023000	GB70.1 Hexagon M8×35 (environmental color zinc)	2	
11	1184100-098000	ZT250-R combination lock	1	
12	1251100-121093	Non-standard bolt M6×25 (environmental color)	2	

PROCEDURE:

● Handlebar assembly

Pick up the decorative buckle(1) with a razor blade, hold the direction handle(4) with one hand, remove the bolt(2) with a hexagonal tool in one hand, remove the pressure block(3), the right pad block(5), the left pad block(6), and finally remove the handle(4).

● Upper plate assembly

Remove nut(7) with tool and remove washer(8).

Remove the bolt(10) with the hexagonal tool and use a slotted screwdriver to slightly open the slot on the upper plate as shown by the arrow. Remove the upper plate assembly.

Remove the bolt(12) with the hexagonal tool and separate the combination lock(11) and the upper plate(9).

● Combination lock function

Press the "PUSH" button to close the key hole after pulling out the key; use the key head to insert the clockwise direction to open the key hole.

Insert the key in the "OFF" position and turn it clockwise to the "ON" position to turn on the ignition circuit. Press the ignition button on the switch to start the vehicle. Turning back to the "OFF" position will cause the vehicle to turn off and off before removing the key.

After turning the key in the "OFF" position, turn it clockwise to open the tank lock.

Press the key in the "OFF" position and turn it counterclockwise to lock the front.

Turn the seat cushion lock counterclockwise in the "OFF" position.

CAUTION:

● The motorcycle should be fixed before operation. During the removal process, the material should be protected to prevent scratches.

● Remove the head assembly, switch, cable, balance block, etc. according to the previous operation.

● Remove the direction of the assembly can not be rotated, loosen the clamp bolt(2) should promptly remove the left and right pads.

● Be careful when opening the slot on the upper plate to prevent damage.

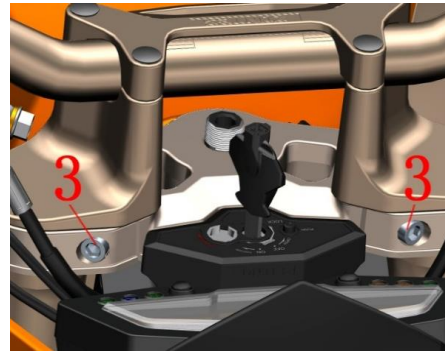
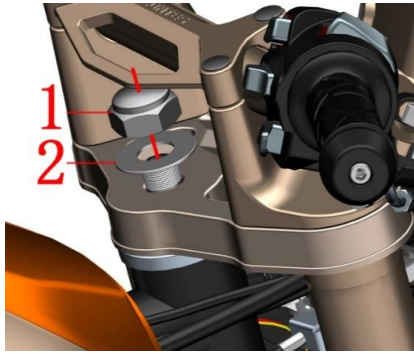

FIG.23 FRONT FORK COMPONENT		Steering adjustment	CHK	
NO.	PART NO.		ADJ	
1	1251300-045000	ZT250-S Upper connection decorative nut	1	
2	1251500-050000	ZT250-S Upper connection gasketφ18.5×φ39×1	1	
3	1250205-023000	GB70.1 Hexagon M8×35 (environmental color zinc)	2	
4	1134100-040000	ZT250-S Adjusting nut locking washer(5 pcs/after-sale)	1	
5	1251300-046093	ZT250-S Direction column adjusting nut M24X1	2	
6	1244100-135000	ZT250-S Adjusting nut rubber gasket (5 pcs/after-sale)	1	
7	1224100-005000	ZT250-S Direction column dust cover	1	
8	1130900-053000	ZT250-S shaft ring (after-sale)	1	
9	1130900-054000	ZT250-S conjoined steel ball (5 pcs/after-sale)	2	
10	1130900-052000	ZT250-S upper steel bowl (after-sale)	2	

PROCEDURE:

- When the front fork slightly sways or when the direction handle swings during braking
Check whether the pressure of the front tire is the recommended air pressure at room temperature: 250±10kPa. If it is lower than the recommended air pressure, the front tire pressure should be inflated to 350 kPa first, and then deflated to 250±10 kPa. Let us check if the running-up test is released. If not, set the front wheel and turn to inspect the tire tread, if it is worn or deformed, the front tire needs to be replaced. If not, you should continue to the following operation.

● Check steering device

Set up the front wheel and shake the lower part of the fork by hand to check if the steering shaft is loose or the left and right rotation is flexible.

Adjust the adjusting nut:

Remove the trim nut(1) with a spanner, remove the gasket(2), and remove the bolt(3) with the hexagonal tool. The direction of the upper connection assembly wrapped with a clean cloth and then placed to prevent scratches. Remove the lock washer(4); remove the top adjusting nut(5) with a special four-jaw shank or hook wrench and remove the pad(6). If the steering resistance is too large, rotate the bottom adjusting nut(5) counterclockwise. If the brake slightly sways or swings, then rotate it clockwise. The torque is approximately 14N.m. It is suitable when holding the front wheel to rotate freely and there is not getting stuck.

When reassembling, the top adjusting nut only needs to be screwed to align with the bottom nut groove, so as not to over-tighten to avoid excessive deformation of the rubber pad(6); the torque requirement of the decorative nut(1) is 100 N.m.

● Steering bearing

If the above operation still can not rule out excessive steering resistance or stuck as follows:

Remove the adjusting nut(5), remove the upper dust cover(7), shaft ring(8), and conjoined steel ball(9), remove the directional column & front shock absorber & front wheel assembly, check the shaft ring and the conjoined steel ball for abnormal wear or rust. At the same time, check whether the seat ring(10) in the front frame of the motorcycle frame is abnormally worn or rusted. If you need to, you need to purchase replacement parts on Zontes official website. Newly-applied conjoined steel balls need to be evenly greased, paying attention to the amount of grease.

CAUTION:

- The vehicle should be fixed and then operated. During the dismantling process, the material should be protected to prevent scratches.

- If the steering adjustment is too tight, the steering force will be greater. If it is too loose, the front of the vehicle will be slightly shaken when braking, and the driver needs to adjust according to the actual needs of the driver.

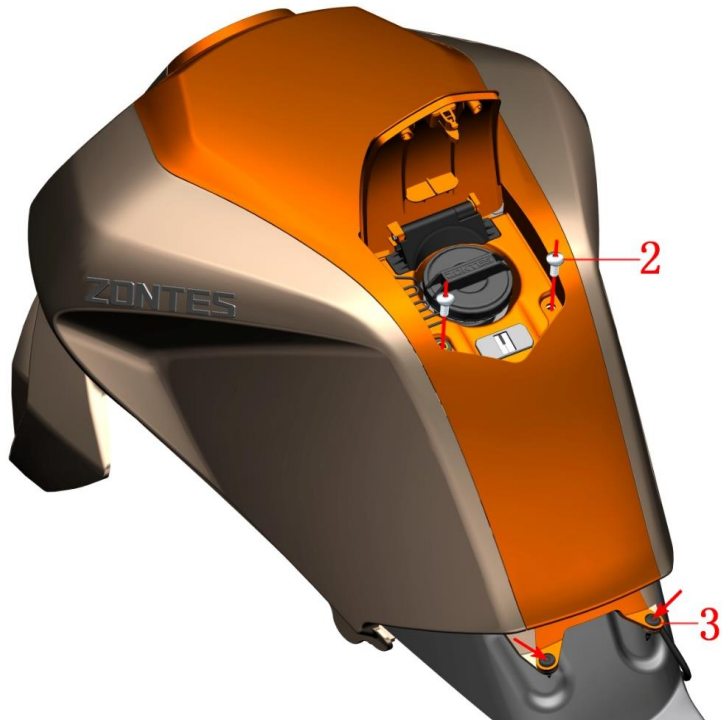
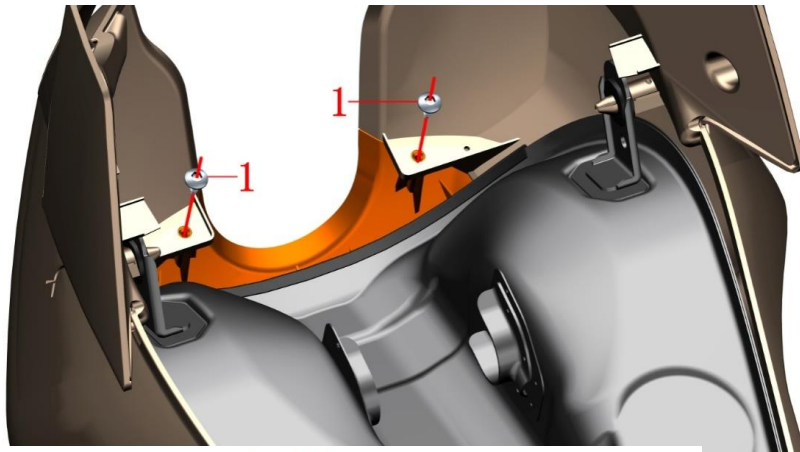

FIG.1 FUEL TANK COVER		Fuel tank middle cover assembly	CHK	
			ADJ	
NO.	PART NO.	PART NAME	QTY	CAUTION
1	1251200-033093	Non-standard nut (environmental color)	2	
2	1251100-102000	Non-standard bolts M6×16 (304 stainless steel)	2	
3	1224100-089000	ZT250-S Expansion nail(5 pcs/after-sale)	2	

PROCEDURE:

● Fuel tank middle cover assembly

After pressing the key in the “OFF” position, turn the fuel tank lock clockwise to open the tank cover. “Fuel tank Liner Assembly” step to remove the connectors of the high pressure oil line and the oil pump and the oil pump cable connector; breather pipe, cushion fixing block, Fuel tank lock time limiter cable connector, Fuel tank lock connector.

Turn the Fuel tank cover and Fuel tank liner assembly upside down and remove the bolt (1). Be careful not to close the Fuel tank cover and take care to protect the paint surface.

Use a small cross screwdriver to press the center of the expansion nail down as shown in ③ and remove the expansion nail. ① is the unmounted state; ② is the assembled state; and ③ is the disassembled state.

Remove the bolt (2) with the hexagonal tool and be careful not to pull the Fuel tank cover nylon rope.

Pull back the middle cover assembly and remove it.

CAUTION:

- The motorcycle support should be fixed during disassembly to prevent accidents caused by incline.
- Do not close the fuel tank cover and do not release the fuel tank cover when disassembling.
- When the high pressure fuel pipe is removed, the engine and the muffler must be completely cooled before they can be operated to prevent accidental ignition of the fuel.
- Fireworks should be strictly prohibited in the vicinity of the motorcycle repair place, answering or dialing, etc. to prevent accidents.
- A small amount of fuel leaks when the high pressure pipe subassembly is pulled out. Prevent the fuel from dripping outside the engine or muffler.
- When disassembling the tank assembly, it is recommended that the fuel be pumped out or consumed after the fuel pump is used.
- The torque of the self-tapping screw during reassembly should not be too large to prevent damage to the fuel tank cover.

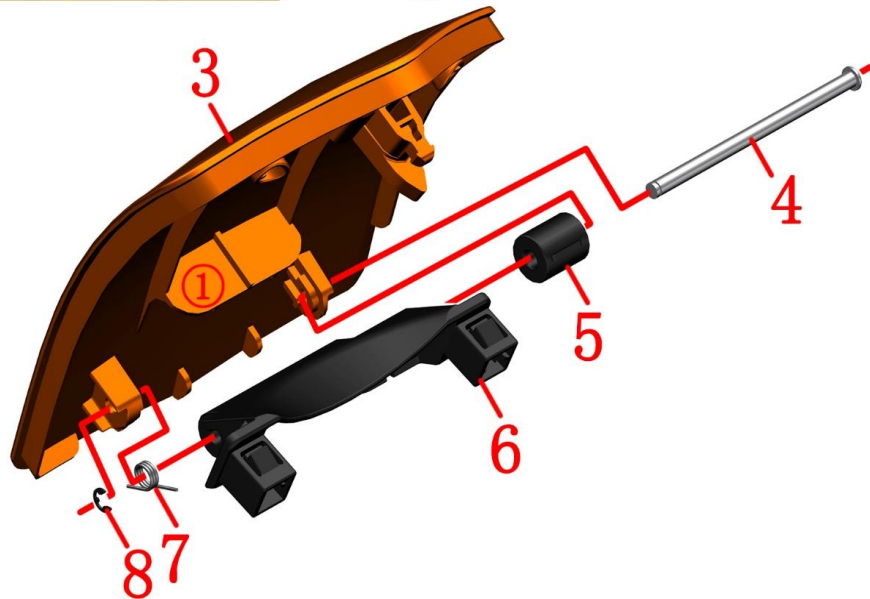
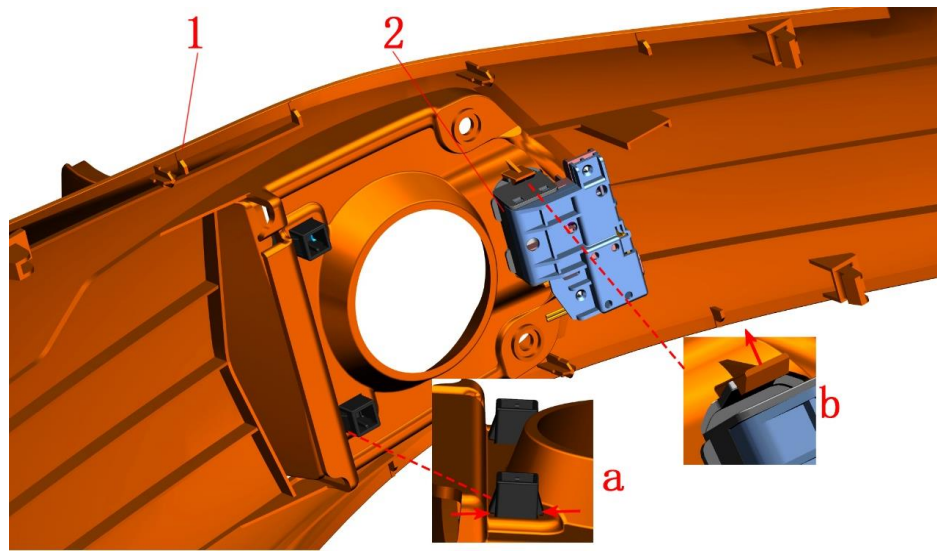

FIG.2 FUEL TANK COVER		Fuel tank middle cover、Fuel tank cover、Fuel tank lock	CHK	⚠
			ADJ	
NO.	PART NO.	PART NAME	QTY	CAUTION
1	4044101-003033	ZT250—R Fuel tank middle cover (bright orange)	1	orange
	4044101-003063	ZT250—R Fuel tank middle cover (dark blue)		dark blue
	4044101-003064	ZT250—R Fuel tank middle cover (bright blue)		blue
	4044101-003041	ZT250—R Fuel tank middle cover (bright green)		green
2	1184200-044000	ZT250 Electronic Fuel tank lock	1	
3	4044100-010033	ZT250—S Fuel tank cover (bright orange)	1	orange
	4044100-010063	ZT250—S Fuel tank cover (dark blue)		dark blue
	4044100-010064	ZT250—S Fuel tank cover (bright blue)		blue
	4044100-010041	ZT250—S Fuel tank cover (bright green)		green
4	1274101-016000	ZT250-S rotating axle of fuel tank outside cover(after-s	1	
5	1224100-014000	ZT250—S Fuel tank cover spinning damping	1	
6	1274100-021000	ZT250—S Fuel tank cover rotating bracket	1	
7	1260100-255000	ZT250-S torsion spring of tank outer cover rotating shaft	1	
8	1260100-469000	ZT310-T storage box cover rotating shaft limit circlip(5 pcs/after-sale)	1	

PROCEDURE:

●Fuel tank lock

Use a slotted screwdriver to carefully open the two ends of the middle cover, as shown in Figure b, remove the Fuel tank lock (2), pay attention to prevent damage to the buckle.

●Fuel tank cover assembly

Hold the clamp of the rotating bracket (6) with a needle-nose pliers and clamp it sbrightly. As shown in Figure a, remove the cover assembly and pay attention to prevent damage to the buckle.

Use the shaft to remove the retainer(8) on the rotation shaft (4) with the circlip pliers. Remove the rotating shaft(4), separate the torsion spring (7), rotating bracket (6), damper (5).

CAUTION:

●Proper material should be protected during disassembly to prevent damage to the paint surface.

●Take care when disassembling the buckle to prevent damage to the buckle.

●Be careful not to lose your own spring when removing the rotating bracket

●When assembling, pay attention to whether the length of the process clip ① on the cover is too long. If it is too long, be sure to cut it short.

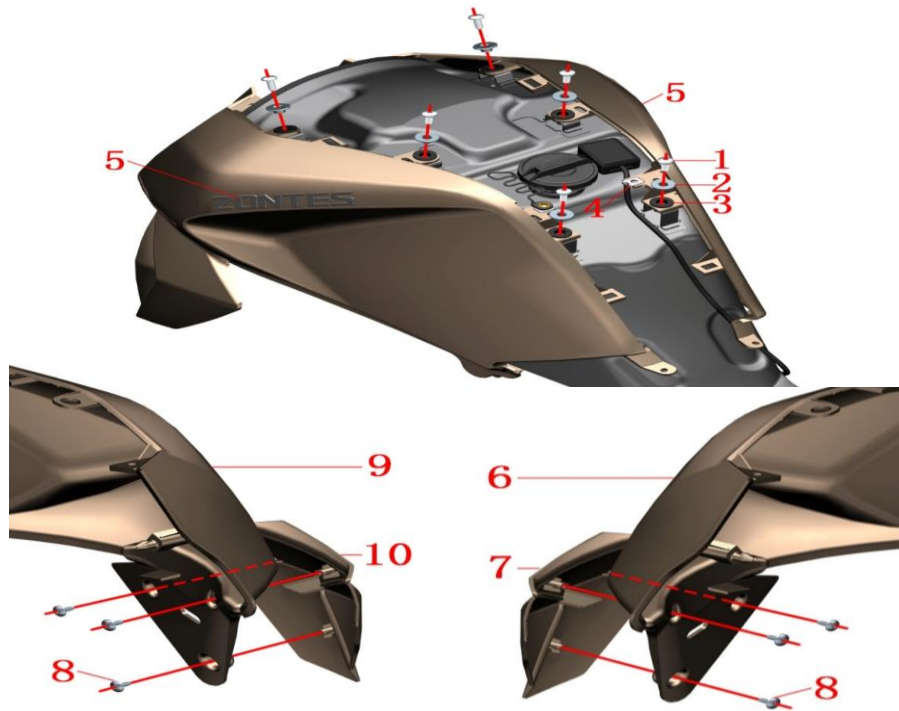

FIG.3 FUEL TANK COVER		Fuel tank left and right cover assembly	CHK	⚠
NO.	PART NO.	PART NAME	ADJ	
			QTY	CAUTION
1	1251100-102000	Non-standard bolt M6×16 (stainless steel)	6	
2	1274101-015000	ZT250-S flanging sleeve(φ6.4×φ9×6+φ20×2)(5 pcs/af	6	
3	1244100-137000	ZT250-S Flanging bushing buffer(5 pcs/after-sale)	6	
4	1251300-063093	Plywood M6×11×15 (environmental color)	2	
5	1210141-001000	ZT250—S Fuel tank sticker	2	for after-sale
6	4044101-002051	ZT250—R Right Fuel tank cover (titanium)	1	orange
	4044101-002063	ZT250—R Right Fuel tank cover (dark blue)		dark blue
	4044101-002052	ZT250—R Right Fuel tank cover (bright grey)		green&blue
7	4044100-011051	Right side cover decorative cover (titanium)	1	orange
	4044100-011063	Right side cover decorative cover (dark blue)		dark blue
	4044100-011052	Right side cover decorative cover (bright grey)		green&blue
8	1251200-033093	Non-standard tapping screw ST4.2×12	6	
9	4044101-001051	ZT250—R Left Fuel tank cover (titanium)	1	orange
	4044101-001063	ZT250—R Left Fuel tank cover (dark blue)		dark blue
	4044101-001052	ZT250—R Left Fuel tank cover (bright grey)		green&blue
10	4044100-013051	Left side cover decorative cover (titanium)	1	orange
	4044100-013063	Left side cover decorative cover (dark blue)		dark blue
	4044100-013052	Left side cover decorative cover (bright grey)		green&blue

PROCEDURE:

● Fuel tank left and right cover assembly

Remove the bolt (1), bushing (2), buffer rubber (3) and plywood (4) with the hexagonal tool. Remove the fuel tank left and right cover assembly.

● Disassemble fuel tank left cover assembly

Remove the screw (8) with the hexagonal tool, remove the left side cover decorative cover (10), and the left Fuel tank cover (9).

● Disassemble fuel tank right cover assembly

Remove the screw (8) with the hexagonal tool, remove the right side cover decorative cover (7), and the left Fuel tank cover (6).

● Fuel tank sticker

If the Fuel tank sticker needs to be replaced with a hot air gun or a hair dryer, it can be moved back and heated and then torn off. The fuel tank sticker can be purchased separately as an optional part. Crude fuel tank left and right Fuel tank covers already contain this sticker

CAUTION:

- The paint surface should be protected when disassembling, pay attention to strength.
- The torque of the tapping screw should not be too large during reassembly to prevent damage to the Fuel tank cover.
- Orange use for orange vehicle; green&blue use for bright green&bright blue vehicle; dark blue use for dark blue vehicle.

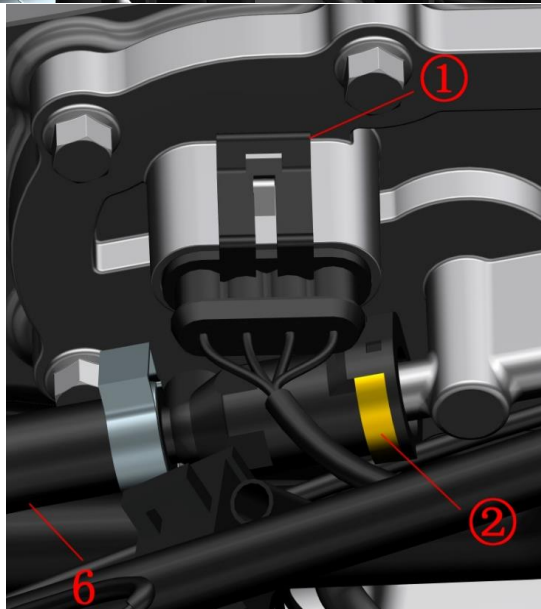
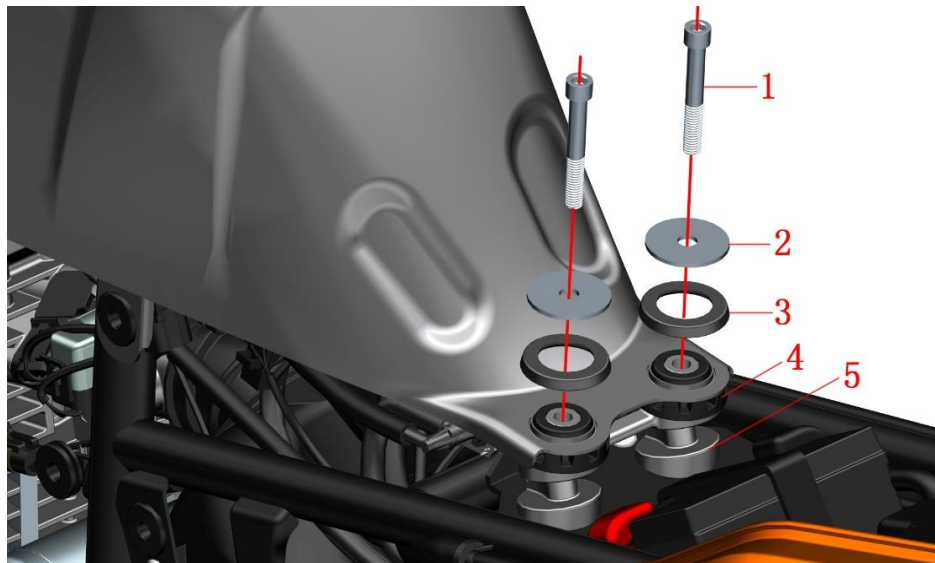

FIG.1 FUEL TANK INNER COVER		Fuel tank inner tank component	CHK	
NO.	PART NO.	PART NAME	ADJ	
1	1250205-043093	GB70.1M8×55 (environmental color)	2	
2	1251900-028093	Fuel tank flat gasket (environmental color)	2	
3	1244100-020000	Fuel tank press rubber	2	
4	1244100-053000	Fuel tank gasket rubber	2	
5	1274100-080000	Seat fixed block	1	
6	1050954-006000	Fuel injection high pressure subcomponent	1	

PROCEDURE:

- Fuel tank inner tank component
Remove the bolts (1) with the inner hex tool; Remove flat gasket (2) and press rubber (3).
Lift the rear of the tank, remove the gasket rubber (4) and fix the seat block (5).
Pull the main line limit card ① into the outside and pull out the plug.
Find the limit card ring ② on the top of the high pressure tubing unit (6), and press the pressure to the outside.
Continue to raise the tank's bladder component, clamp the pipe clamp on the air pipe by the arrow direction, and remove the vent pipe.
Move the tank inside the tank slightly to the left and right and then pull back to the top.

CAUTION:

- Remove the seat cushion, side cover, fuel tank cover, etc. in advance.
- When the high pressure fuel pipe is removed, it must be operated after the engine and muffler are completely cooled to prevent accidental ignition of the fuel.
- Fireworks should be strictly prohibited in the vicinity of the motorcycle repair place, answering or dialing, etc. to prevent accidents.
- A small amount of fuel leaks when the high pressure pipe subassembly is pulled out. Prevent the fuel from dripping outside the engine or muffler.
- When disassembling the tank assembly, it is recommended that the fuel be pumped out by the fuel pump or consumed at first.

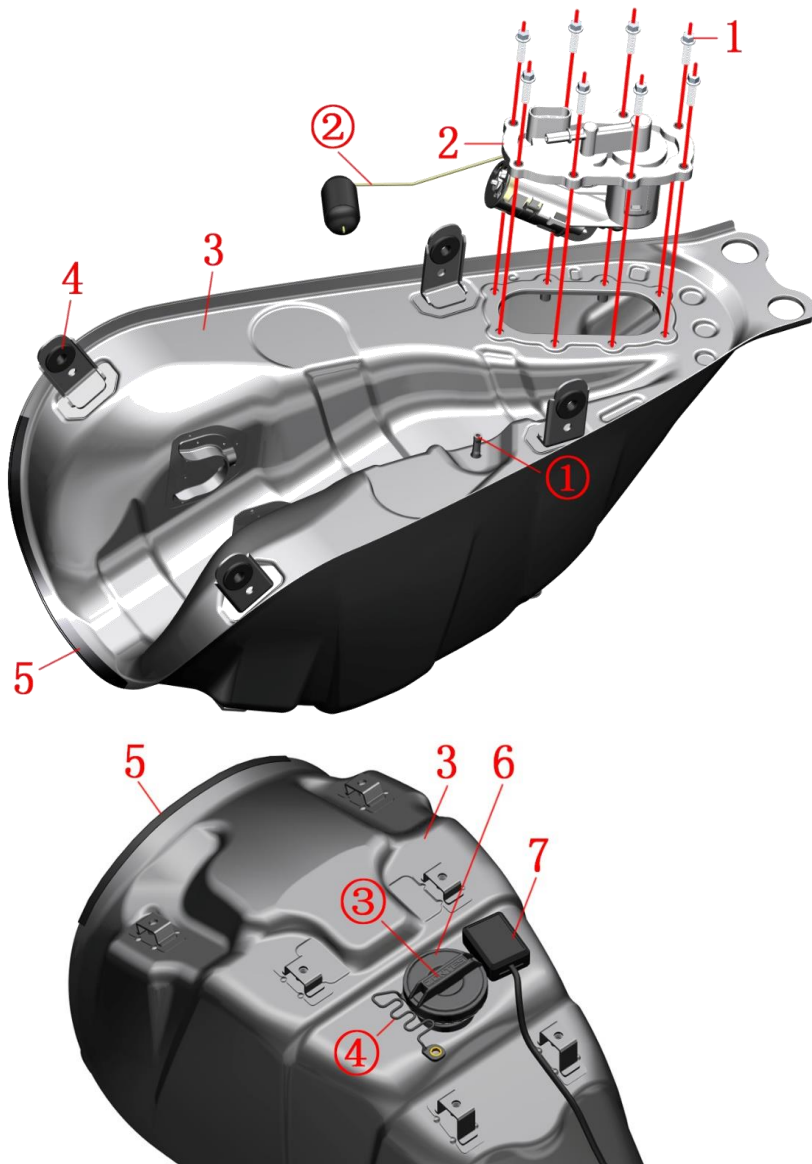

FIG.2 FUEL TANK INNER COVER		Fuel tank inner tank	CHK	⚠
NO.	PART NO.	PART NAME	ADJ	
1	1250105-137093	GB5789M6×16 (environmental color)	8	CAUTION
2	1050953-020000	T02 built-in fuel pump	1	
3	4034100-006000	Fuel tank inner tank	1	
4	1244100-138000	ZT250-S Side cover round rubber(5 pcs/after-sale)	4	
5	1240300-397021	HJ125-6 pod glass strip (1.5m)(after-sale)	0.17	
6	1224100-033000	Fuel tank cap	1	
7	1184100-099000	Fuel tank lock timer limiter	1	
8	1164100-006000	T02 oil level sensor	1	for after-sale

PROCEDURE:

● Fuel pump

Place the tank inside the tank and place it firmly and remove the bolt (1) with the sleeve.

When the fuel pump (2) is removed, do not bend or bend the float rod to prevent the oil output from being inaccurate.

● Side cover round rubber

Squeeze the side cover round the side of the glue (4) with your hand and squeeze it out of the tank.

● Timer limiter

Tear down the limiter (7). If you can't remove it, you can heat it with a hot air gun or a hair dryer. When reassembling, if the adhesive has been reduced, clean the double-sided adhesive, re-paste the new 3M double-sided adhesive, and clean the tank surface of the tank.

● Plastic piece

Use your hand to tear off the tape (5) at the end of the tape.

● Fuel tank cap

Use your hands to squeeze the bottom of the oil box (3) in a counterclockwise rotation. You can't pull the nylon rope.

CAUTION:

● When disassembling the tank assembly, it is recommended that the fuel be pumped out by the fuel pump or consumed at first.

● Fireworks should be strictly prohibited in the vicinity of the motorcycle repair place, answering or dialing, etc. to prevent accidents.

● Reverse the tank assembly. When removing the fuel pump, be sure to check whether the fuel tank cover has been tightened to prevent residual fuel from escaping from the tank port; there may be a small amount of fuel in the vent pipe (1) when the tank cover is removed.

● When reassembling the fuel pump, be sure to clean the joint surfaces of the clean fuel pump seal pad and the tank liner. When locking the bolt, ensure that the seal gasket is evenly deformed by staggering the position.

● It is forbidden to forcefully pull the cable when removing the timer lock.

● T02 oil level sensor dose not contain fuel pump body。 Make sure you have the ability to change it.

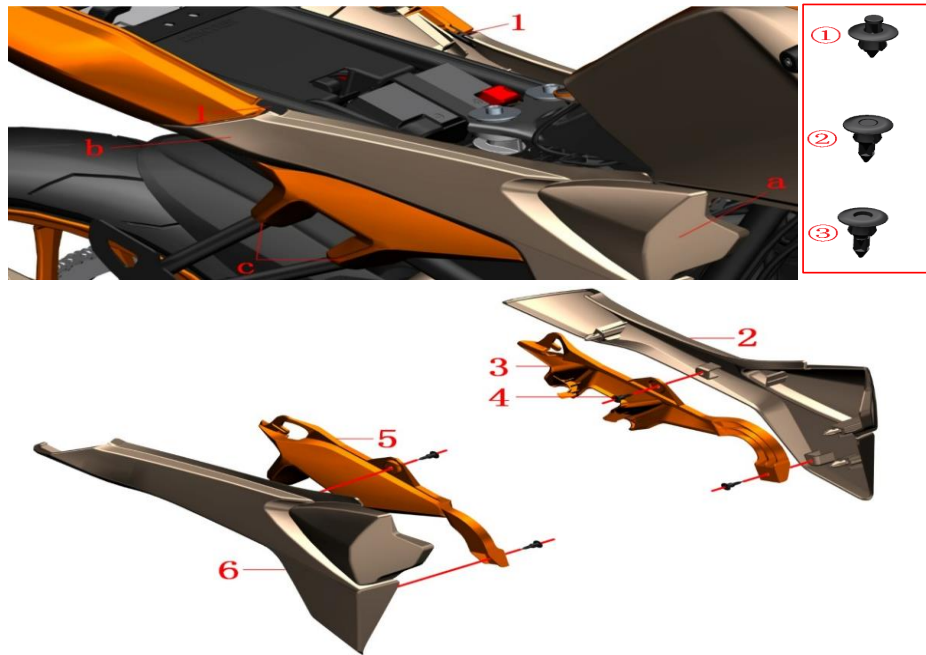

FIG.1 SIDE COVER COMPONENT		Side cover assembly	CHK	⚠
NO.	PART NO.	PART NAME	ADJ	
			QTY	CAUTION
1	1224100-024000	ZT250—S Plastic connection piece	2	
2	4044100-016051	ZT250—S Left side cover (titanium)	1	orange
	4044100-016063	ZT250—S Left side cover (dark blue)		dark blue
	4044100-016052	ZT250—S Left side cover (light gray)		green&blue
3	4044100-021033	Left side cover decorative cover (bright orange)	1	orange
	4044100-021051	Left side cover decorative cover (titanium)		dark blue
	4044100-021064	Left side cover decorative cover (light blue)		blue
	4044100-021041	Left side cover decorative cover (light green)		green
4	1224100-089000	ZT250-S Expansion nail(5 pcs/after-sale)	4	
5	4044100-020033	Right side cover decorative cover (bright orange)	1	orange
	4044100-020051	Right side cover decorative cover (titanium)		dark blue
	4044100-020064	Right side cover decorative cover (light blue)		blue
	4044100-020041	Right side cover decorative cover (light green)		green
6	4044100-014051	ZT250—S Right side cover (titanium)	1	orange
	4044100-014063	ZT250—S Right side cover (dark blue)		dark blue
	4044100-014052	ZT250—S Right side cover (light gray)		green&blue

PROCEDURE:

●Side cover assembly

Remove the plastic connection piece (1).

Press the a-end of the right side cover to pull out forcibly, then pull out the b-end, remove the right cover assembly; Similarly remove the left cover assembly.

Use a small cross screwdriver to press the center of the expansion nail down as shown in ③ and remove the expansion nail. ① is the unmounted state; ② is the assembled state; and ③ is the disassembled state.

Separate the side cover and the side cover decorative cover.

CAUTION:

●Make sure the motorcycle is fixed during the process of disassembly.

●Use force to pull outwards when removing the side cover assembly, do not pull it diagonally to prevent breaking the staple bolt.

●When assembling the side cover assembly, it should first install the b-end, then install the a-end, and then press c-end to attach the decorative cover to the frame pipe.

●Orange use for orange vehicle; green&blue use for bright green&bright blue vehicle; dark blue use for dark blue vehicle.

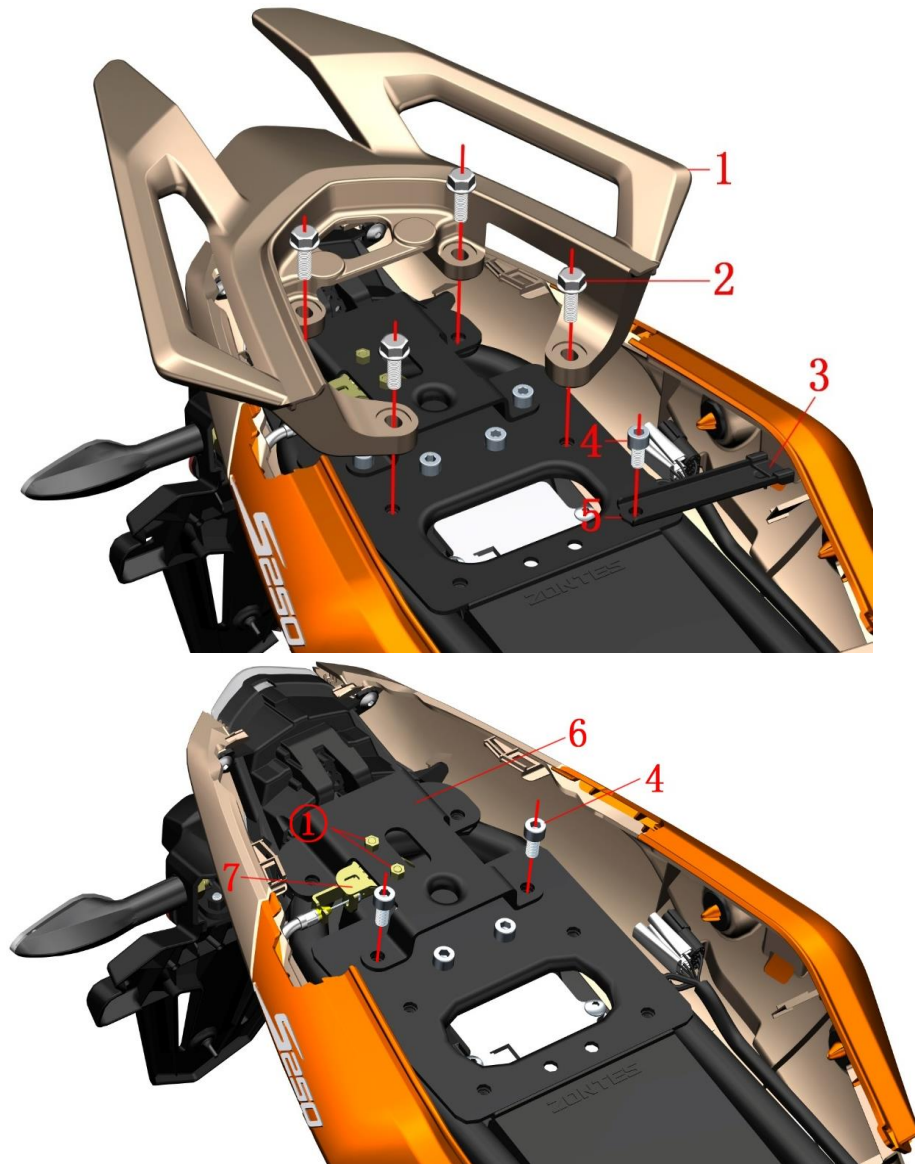

FIG.1 REAR COVER COMPONENT		Rear handrail、Cushion lock bracket	CHK	CAUTION
			ADJ	
NO.	PART NO.	PART NAME	QTY	
1	1144100-001000	ZT250—S Rear handrail	1	
2	1251100-123093	Non-standard bolt M8×25 (environmental color)	4	
3	1244100-065000	ZT250-S rear cover left limit rubber	1	
4	1250205-040095	GB70.1hexagon socket screw M8×16 (environmental color)	3	
5	1274100-075000	ZT250—S Rear cover left limit bracket	1	
6	4024100-004000	ZT250—S Cushion lock bracket	1	
7	1274100-023000	ZT250—S Cushion lock	1	

PROCEDURE:

- Rear handrail
Remove the bolt (2) with the sleeve and remove the rear handrail (1).
 - Rear cover left limit bracket
Remove the bolt (4) in the upper left figure with the inner hexagon tool.
Remove the left limit bracket (5) and remove the lower limit rubber (3) from the bracket.
 - Cushion lock bracket
Remove the two nuts ① from the seat cushion lock with a sleeve, remove the seat cushion lock (7) from the bracket (6), and screw the nut onto the cushion lock.
Remove the two bolts (4) in the lower left figure with the inner hexagon tool and remove the seat lock bracket (6).
- If you want to completely remove the seat cushion lock, pull the cushion pull ball head upwards to pull out the seat groove of the cushion lock, and then pull out the bent tube, so you can't bend or over bend the cable core.

CAUTION:

- Make sure the motorcycle is fixed during the process of discomponent.
- In the process of discomponent, the material should be protected to prevent damage to the paint surface.

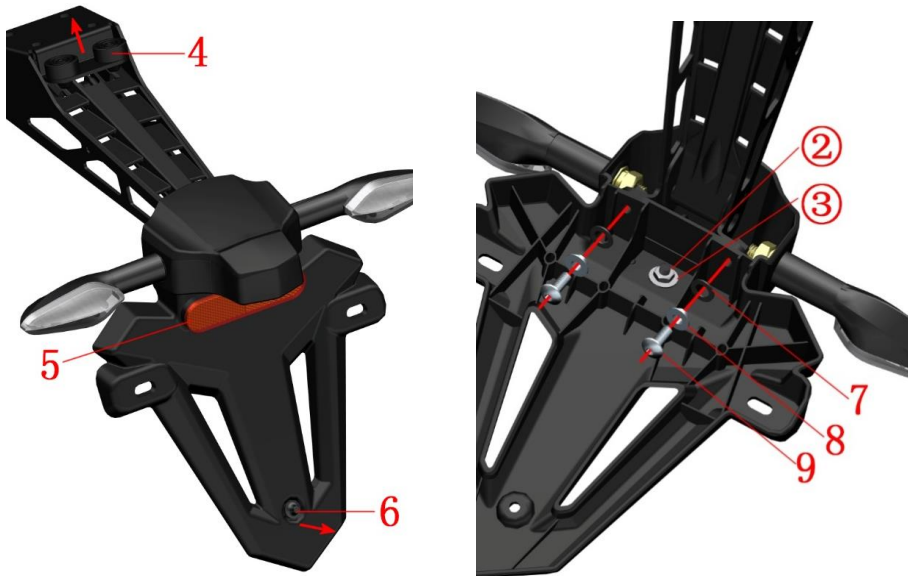
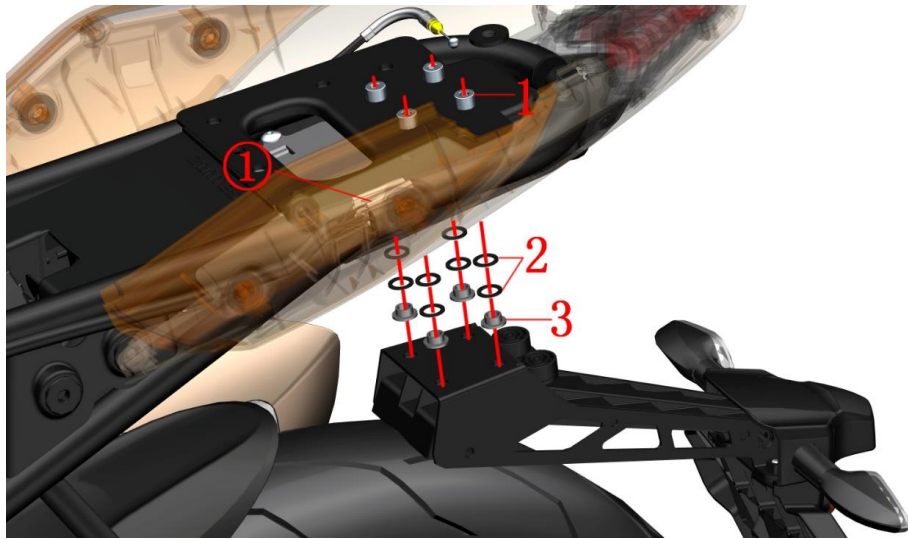

FIG.2 REAR COVER COMPONENT		Rear mudguard component	CHK	CAUTION
			ADJ	
NO.	PART NO.	PART NAME	QTY	
1	1250205-040095	GB70.1Hexagon socket bolt M8×16	4	
2	1240300-071000	Flanged bushing buffer (φ11×φ16×1)	8	
3	1251700-058093	Flanged bushingφ8.2×φ11×4.5+φ16×1.5	4	
4	1244100-025000	ZT250—S Cushion round rubber	2	
5	1174100-015000	ZT250-S rear reflector(after-sale)	1	
6	1244100-136000	ZT250-S rear liceness buffer rubber(5 pcs/after-sale)	1	
7	1241200-124021	flanging bushing buffer rubber (φ8.5×φ14×1)(5 pcs/after-sale)	2	
8	1274100-155095	Flanged bushing φ6.2×φ8.4×3.5+φ14×1.5(5 pcs/after-sale)	2	
9	1251100-102000	Non-standard bolt M6×16 (stainless steel)	2	

PROCEDURE:

●Rear mudguard component

Pull out the thread head ① and pull out the rear turn light, license plate light and tail light. Then hold the rear mudguard component and remove the bolt (1) with the hexagon socket tool. Remove the rear mudguard component and remove the eight buffer rubbers (2) and four pieces of bushings(3).

Pull out the round rubber(4) in the direction of the arrow; pull out the plate cushion rubber(6) in the direction of the arrow.

Hold the rear reflector with one hand, remove the nut ② and washer ③ with the other hand and remove the rear reflector(5).

Remove the bolt(9) with the hexagonal tool, remove the bushing (8), buffer rubber(7) and divide the rear mudguard component into two parts.

CAUTION:

- Make sure the motorcycle is fixed during the process of discomponent.
- If the connector is loose when re-inserting the bullet type cable connector, use the pliers to clamp the female connector slightly and insert it again.

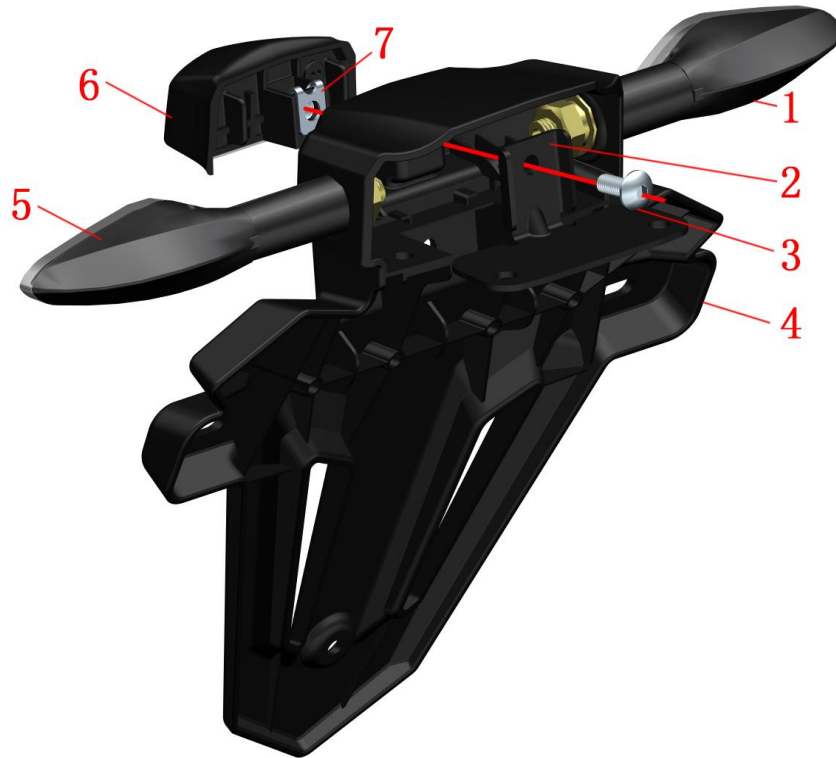



FIG.3 REAR COVER COMPONENT		Rear mudguard subcomponent	CHK	
NO.	PART NO.	PART NAME	ADJ	
1	1174100-005000	ZT250—S Front left turn signal light	1	CAUTION
2	4024100-008000	ZT250—S Rear mudguard bracket connector	1	
3	1251100-102000	Non-standard bolt M6×16 (stainless steel)	1	
4	1224100-017000	ZT250—S Rear mudguard	1	
5	1174100-006000	ZT250—S Front right turn signal light	1	
6	1174100-003000	ZT250—S Rear license plate light	1	
7	1251300-063093	Plywood M6×11×15 (environmental color)	1	

PROCEDURE:

- Pull the turn signal light and license plate light cable out of the rear mudguard bracket component, taking care not to over-pull or bend the cable.
- Bracket connector, Rear license plate light.
Hold the rear license plate light (6) with one hand, remove the bolt (3) by hexagonal tool with the other hand and remove the bracket connector (2).
Remove the rear license plate light (6) and remove the plywood nut (7).
- Rear turn signal light
After grasping the mud plate (4) with one hand, remove the nuts, spring washers, and gaskets of the left turn signal light (1) and the right turn signal light (5) with an open end wrench and remove them from the rear mudguard plate.

CAUTION:

- Do not excessively pull or bend the cable of the light during disassembling.
- If the connector is loose when re-inserting the bullet type cable connector, use the pliers to clamp the main connector slightly and insert it again.
- When refitting the turn signal light, pay attention to the lug boss on the light handle corresponding to the opening of the rear mudguard plate, and then tighten the turn signal light and then fasten it. Note that after inserting the cable first, then insert the gasket - spring washer - nuts - tighten the nuts.

FIG.4 REAR COVER COMPONENT		Rear mudguard bracket component		CHK	
NO.	PART NO.	PART NAME	QTY	ADJ	
1	4024100-007000	ZT250—S Rear mudguard bracket connector	1		
2	1224100-018000	ZT250—S Rear mudguard bracket panel	1		
3	1224100-019000	ZT250—S Rear mudguard bracket panel cover	1		

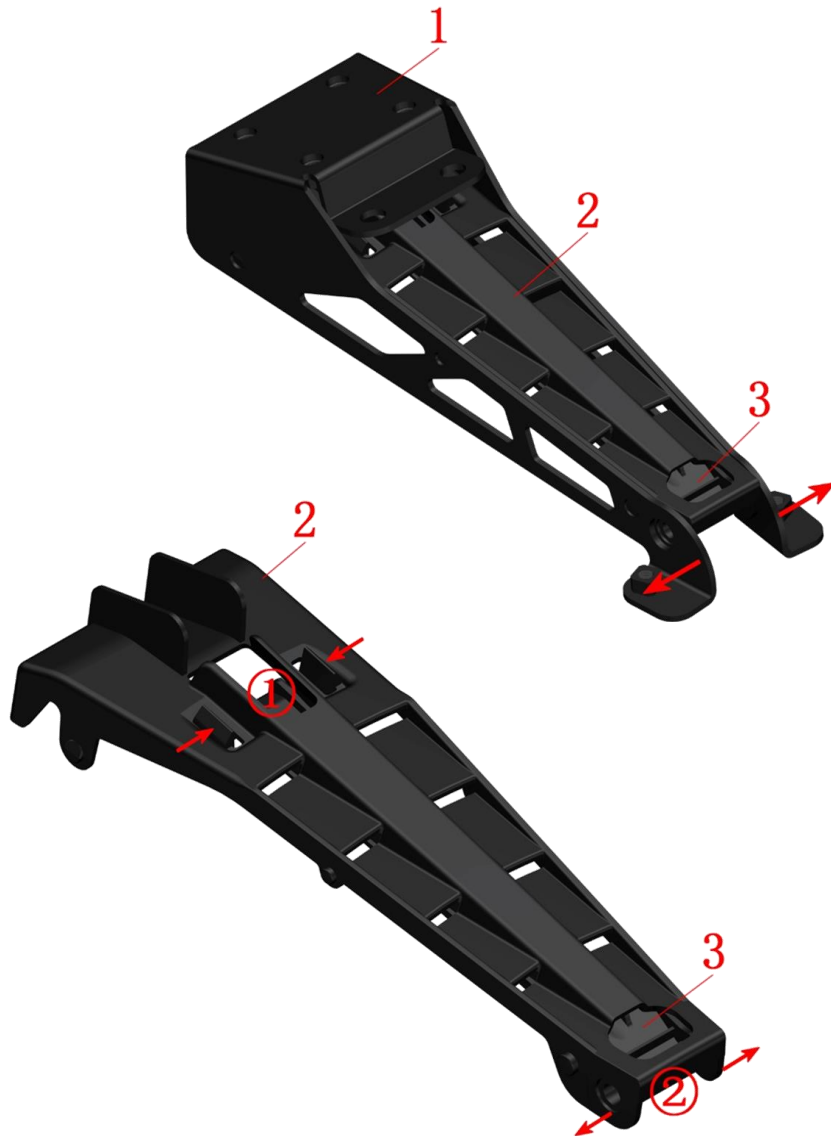

PROCEDURE:

●Rear mudguard bracket

Loosen the tail of the rear mudguard bracket (1) in the direction of the arrow in the above figure to remove the panel component.

●Panel cover component

First press the buckle on the panel cover (3) in the direction indicated by arrow ① and remove it from the panel (2).

Then open the panel (2) in the direction of arrow ② and remove the panel cover (3).

CAUTION:

●Pay attention to the discomponent process to avoid damaging the material.

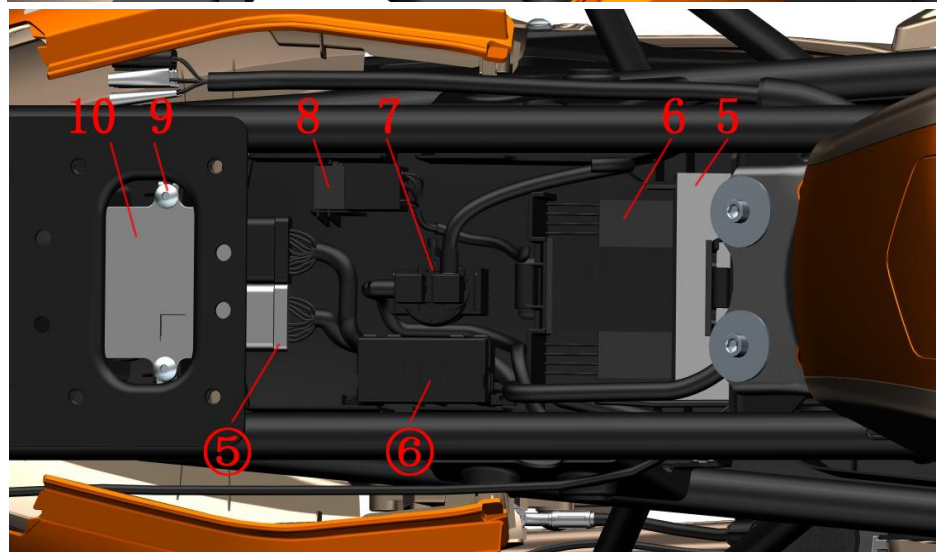
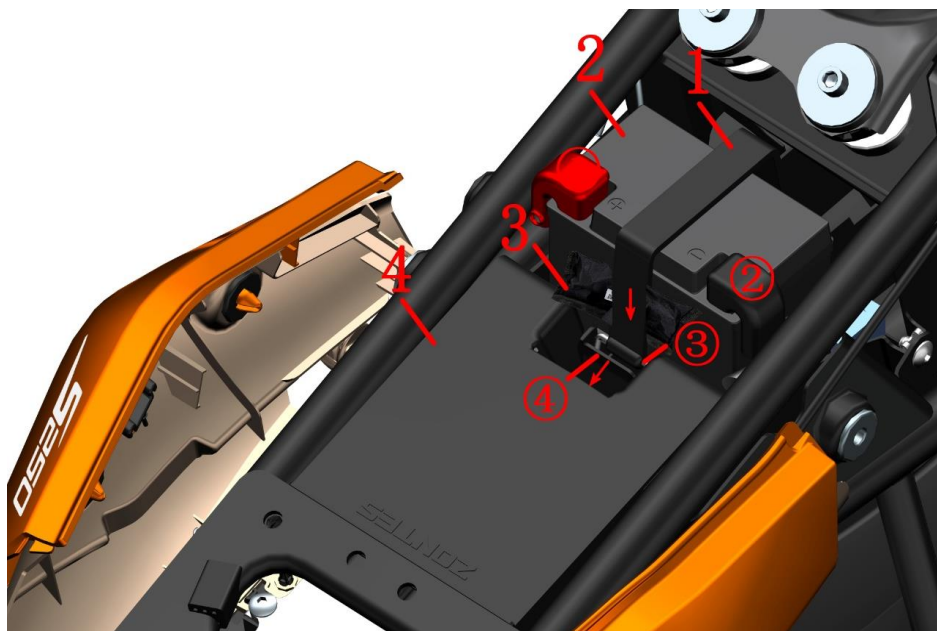

FIG.5 REAR COVER COMPONENT		Battery、Electrical device box cover、ECU	CHK	⚠
			ADJ	
NO.	PART NO.	PART NAME	QTY	CAUTION
1	1240100-018000	Battery strap	1	
2	1184100-100000	ZT250-R Battery (YTZ7-BS)	1	
3	1274100-053000	ZT250-S Motorcycle tool	1	
4	1224100-052000	ZT250-R Electrical device box cover	1	
5	1244100-073000	ZT250-R Electric device box sponge pad120×30×30	1	
6	1241200-125000	HJ125-6 Battery rubber gasket(5 pcs/after-sale)	6	
7	1184300-002000	ZT350 Starting relay	1	
8	1186001-018000	ZT250-S Four-pin Normally Open Relay(after-sale)	2	
9	1251100-102000	Non-standard bolt M6×16 (304 stainless steel)	2	
10	1050953-019000	MT05.2 Engine Controller-ZT250-RC3 type	1	

PROCEDURE:

- Electrical device box cover
Snap the electrical device box cover (4) in the direction of the arrow and remove it.
- Battery straps、 Motorcycle tool
Pull the metal buckle ③ of the battery strap (1) in the direction of the arrow, pull it down, remove it, and remove the motorcycle tool (3).
- Battery
Unscrew the black protective cap ② to remove the negative pole; then remove the red protective cap ① to remove the positive pole; remove the battery. For reinstallation, connect the positive electrode first, then connect the negative electrode. Remove the sponge pad (5), the battery pad (6) is a double-sided adhesive sponge pad glued on the electrical device box.
- Starting relay
Pull up the starter relay (7); pull out the EFI relay and cable and pull out the EFI relay (8).
- ECU
Remove the bolt (9) and pull the ECU (10) and the cable together and then pull the ECU plug ⑤ out.
- Engine Controller
Pull out the fuse box and cable and then pinch the fuse box ⑥ with both ends to open the lid and replace the fuse.

CAUTION:

- Pay attention to the strength of the discomponent process to avoid damage to the material; be sure to pay attention to the installation sequence when removing the battery.
- The battery voltage should be checked regularly.It should not be overcharged; it should be taken out of storage for a long time without use, and it should be charged once a month.
- Reassemble the battery or fuse, etc. Remember to reset the EFI hardware: turn on the key - ignite - 10 seconds later turn off the ignition switch - After 10 seconds Turn on the ignition switch and repeat two times.
- If the battery has reached its end of life, it should be handed over to a qualified organization or a dedicated recycling center for proper disposal. Do not discard it at will.

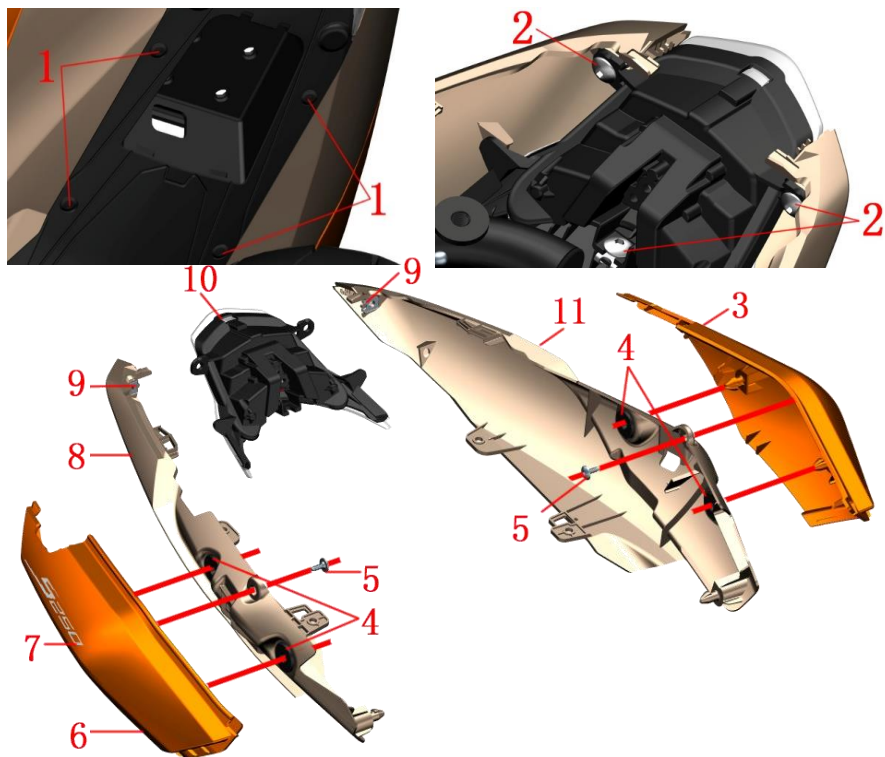

FIG.6 REAR COVER COMPONENT		Rear handrail、Cushion lock bracket	CHK	CAUTION
			ADJ	
NO.	PART NO.	PART NAME	QTY	
1	1224100-089000	ZT250-S Expansion nail(5 pcs/after-sale)	4	
2	1251100-101000	Non-standard bolt M6×12 (304 stainless steel)	3	
3	4044101-006033	Rear cover left trim cover (bright orange)	1	orange
	4044101-006063	Rear cover left trim cover (dark blue)	1	dark blue
	4044101-006064	Rear cover left trim cover (bright blue)	1	blue
	4044101-006041	Rear cover left trim cover (bright green)	1	green
4	1244100-138000	ZT250-S Side cover round rubber(5 pcs/after-sale)	4	
5	1251200-033093	Non-standard self-tapping screw ST4.2×12	2	
6	4044101-007033	Rear cover right trim cover (bright orange)	1	orange
	4044101-007063	Rear cover right trim cover (dark blue)	1	dark blue
	4044101-007064	Rear cover right trim cover (bright blue)	1	blue
	4044101-007041	Rear cover right trim cover (bright green)	1	green
7	1210341-001000	ZT250—R Rear cover sticker	2	【1】
8	4044100-001051	ZT250—S Rear cover right part(titanium)	1	orange
	4044100-001063	ZT250—S Rear cover right part(dark blue)	1	dark blue
	4044100-001052	ZT250—S Rear cover right part(light grey)	1	green&blue
9	1251300-063093	Plywood M6×11×15 (environmental color)	2	
10	1174100-007000	ZT250—S Rear tail light	1	
11	4044100-003051	ZT250—S Rear cover left part(titanium)	1	orange
	4044100-003063	ZT250—S Rear cover left part(dark blue)	1	dark blue
	4044100-003052	ZT250—S Rear cover left part(light grey)	1	green&blue

PROCEDURE:

● Rear cover component

Remove the four expansion nails (1), remove the three bolts (2) with the hexaongal tool, and pull the front end of the rear cover off the frame.

After grasping the tail light (10), push the left rear cover assembly backwards and remove it, remove the right rear cover assembly and remove the tail light (10).

Remove the bolt (5) of the left rear cover assembly, and force the left trim cover (3) and the left rear cover (11) apart, remove the round rubber (4) and the plywood (9).

Similarly remove the right trim cover (6) and the right rear cover (8).

● Sticker

The trim cover of rear cover already contains the rear cover stickers, if you need to replace it, you can buy another one on Zontes official website.

CAUTION:

● Be sure to fix the motorcycle during discomponent.

● Pay attention to the discomponent process to avoid damaging the material.

● Orange use for orange vehicle; green&blue use for bright green&bright blue vehicle; dark blue use for dark blue vehicle.

● 【1】 The trim cover of rear cover already contains the rear cover stickers.

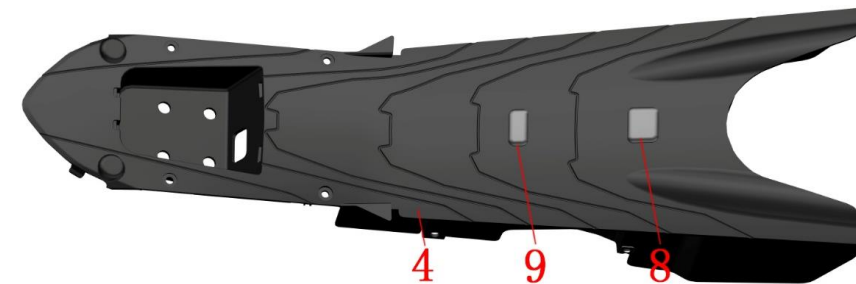
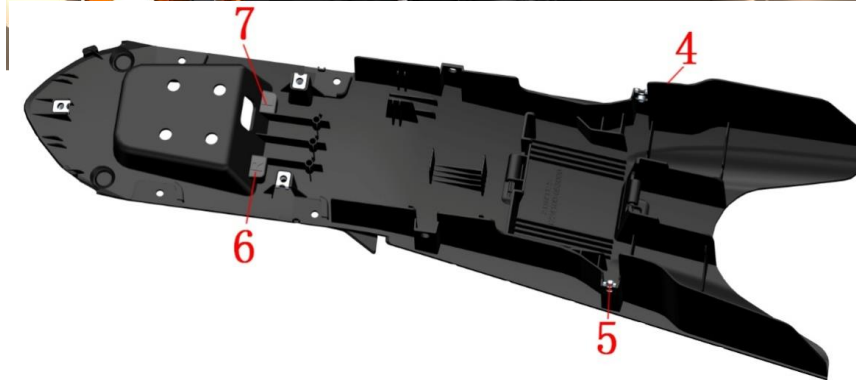
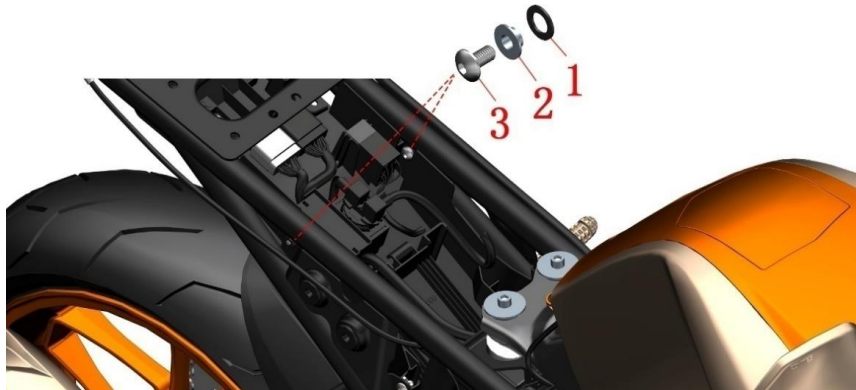

FIG.7 REAR COVER COMPONENT		Electrical device box component	CHK	
NO.	PART NO.		ADJ	
1	1241200-124021	flanging bushing buffer rubber (φ8.5×φ14×1)(5 pcs/after-)	2	
2	1274100-155095	Flanged bushing φ6.2×φ8.4×3.5+φ14×1.5(5 pcs/after-)	2	
3	1251100-101000	Non-standard bolt M6×12 (304 stainless steel)	4	
4	1224100-053000	ZT250-R Electrical device box	1	
5	1251300-063093	Plywood M6×11×15 (environmental color)	5	
6	1244100-080000	ZT250-R Electrical device box right rubber	1	
7	1244100-079000	ZT250-R Electrical device box left rubber	1	
8	1244100-077000	ZT250-R Electrical device box front rubber	1	
9	1244100-078000	ZT250-R Electrical device box rear rubber	1	

PROCEDURE:

- Electrical device box component

Hold the electrical device box, and then use the hexagonal tool to remove the bolts (3) on both sides of the electrical device box, remove the flanged bushing (2), buffer rubber (1); then remove the outer two bolts (3) and take off the electrical device box.

Remove five plywoods (5).

Remove the electrical device box right rubber (6) and the electrical device box rear rubber (7).

Turn over to the back to remove the electrical device box front rubber (8) and the electrical device box rear rubber (9).

CAUTION:

- Be sure to fix the motorcycle during discomponent.
- Pay attention to the discomponent process to avoid damaging the material.



FIG.1 CUSHION COMPONENT		CUSHION COMPONENT	CHK	CAUTION
NO.	PART NO.	PART NAME	ADJ	
1	1204100-006000	ZT250-R Cushion	1	for after-sale
2	1244100-024000	ZT250-R Cushion front rubber	2	
3	1244100-022000	ZT250-R Cushion rubber	2	
4	1244100-025000	ZT250-R Cushion circle rubber	4	
5	1274100-029000	ZT250-R Cushion lock plate	1	
6	1251100-102000	Non-standard bolt M6×16 (stainless steel)	1	

PROCEDURE:

● Seperate cushion

Insert the key in the "OFF" position ,counterclockwise until the sound indicates that the cushion lock is open. Tap the back of the cushion if there is no sound.

Hold the rear cushion in the direction of the arrowhead, while remove the cushion from left and right swing cushion.

● Install cushion

When assembling the cushion, first check whether all the cushion glue is complete, insert the front of the cushion first, and then make a hard clap at the end of the cushion,,when heard "kaca",the cushion lock is in place.

● Cushion rubber,lock plate component for individual sales

If the cushion glue is worn or the cushion lock damaged too much, you can buy the genuine article on the website.

The corresponding installation location is shown in the lower left image.

CAUTION:

- The motorcycle should be fixed and then operated.
- The cushion contains all the cushion glue and lock pieces and bolts.
- It is easy to be surprised when the cushion is not in place.

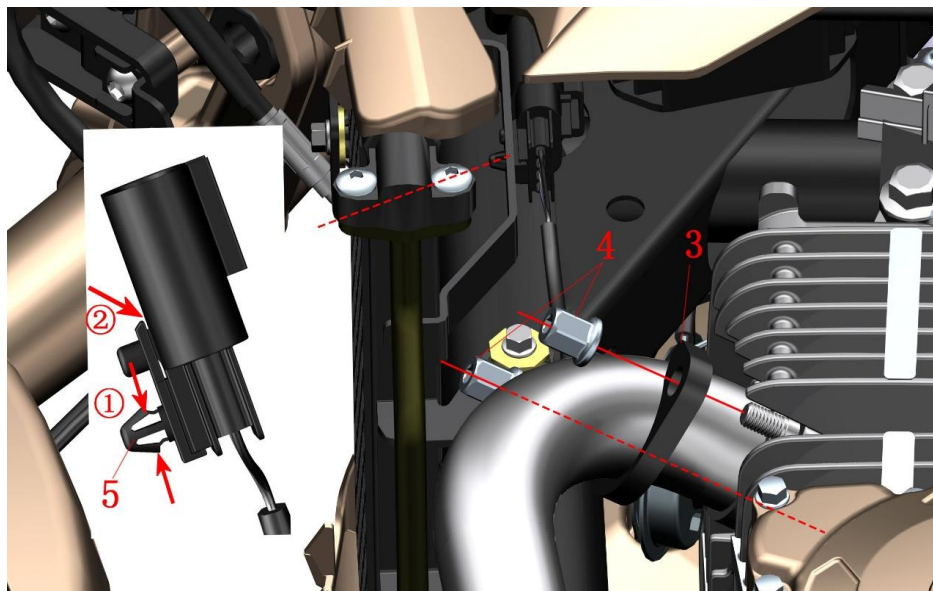
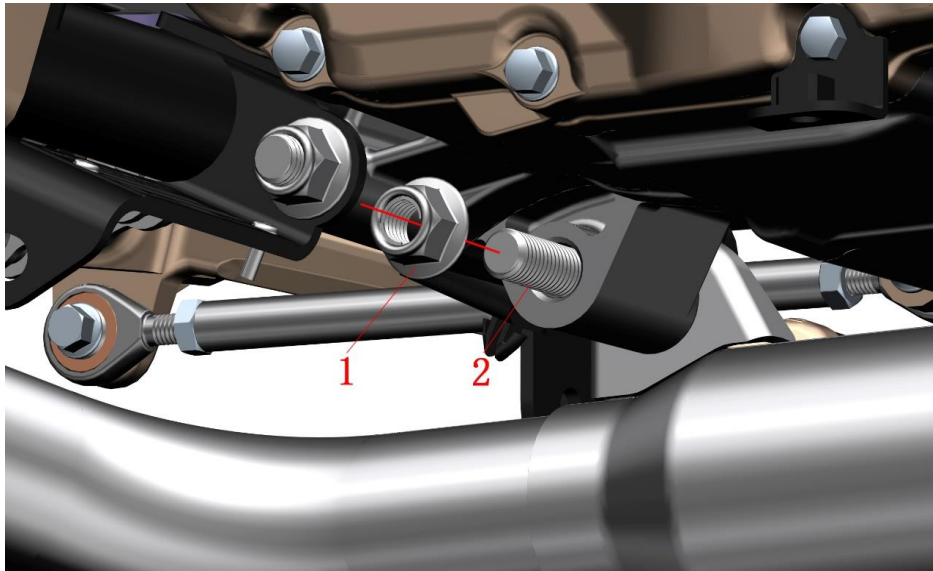

FIG.1 MUFFLER COMPONENT		Remove muffler 1	CHK	
			ADJ	
NO.	PART NO.	PART NAME	QTY	CAUTION
1	1251300-057093	Non-standard bolt M10×1.5	1	
2	1251100-084093	Non-standard bolt M10×1.5×66	1	
3	1020265-155000	ZT250-S muffler flange (outsourcing)	1	
4	1251300-058093	Hexagon nut M8 (color zinc)	2	22~24N.m
5	1224100-013000	ZT250—S Oxygen sensor fixing buckle	1	

PROCEDURE:

● Muffler parts

Fix the motorcycle, use the sleeve to fix the head of the bolt (2) while using the sleeve to remove the nut (1). Please don't remove the bolt (2).

● Oxygen sensor fixing buckle

Use pliers to clamp the rear radiator bracket slightly and pull out the cable clip (5) in the direction shown in ①. Separate the oxygen sensor connector from the main harness. Then use the small straight screwdriver to insert the direction as the arrow ② and remove the cable clip (5) from the oxygen sensor cable connector.

● Flange of muffler

Remove the nut (4) with the inner hexagon tool and then remove the flange (3).

CAUTION:

- In the process of disassembly, the motorcycle should be properly supported to prevent accident caused by incline.
- Make sure the muffler and engine are completely cooled before removing the muffler.
- In the process of disassembly, it should be careful to avoid damaging the material.

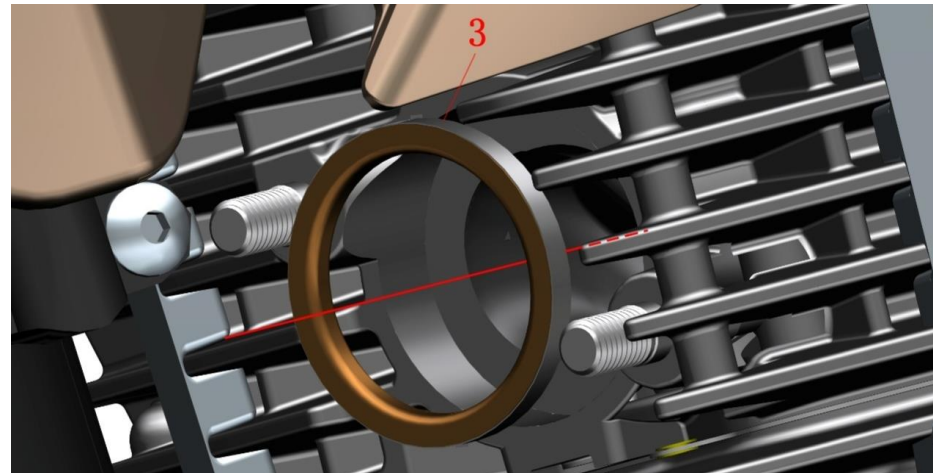
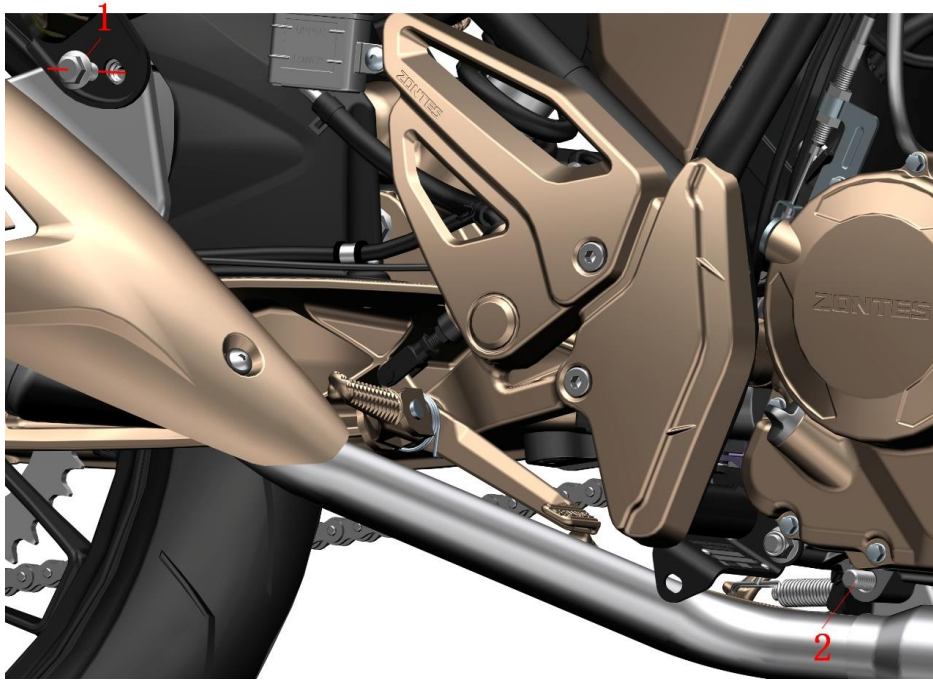

FIG.2 MUFFLER COMPONENT		Remove muffler 2	CHK	
			ADJ	
NO.	PART NO.	PART NAME	QTY	CAUTION
1	1251100-082093	Non-standard bolt M10×1.5×20	1	
2	1251100-084093	Non-standard bolt M10×1.5×66	1	
3	1070100-133000	ZT250—S Engine exhaust port gasket	1	

PROCEDURE:

● Muffler component

Fix the motorcycle, use the sleeve to remove the bolt (1) by holding the muffler tail part with hands, then remove the bolt (2) from the engine while holding the muffler COMPONENT. Remove the muffler from the motorcycle.

● Gasket

Remove the gasket (3) from the exhaust port of the engine.

CAUTION:

● In the process of disassembly, the motorcycle should be properly supported to prevent accident caused by incline.

● Make sure the muffler and engine are completely cooled before removing the muffler.

● In the process of disassembly, it should be careful to avoid damaging the material, It is recommended to replace the new gasket to prevent air leakage every time the muffler COMPONENT is removed.

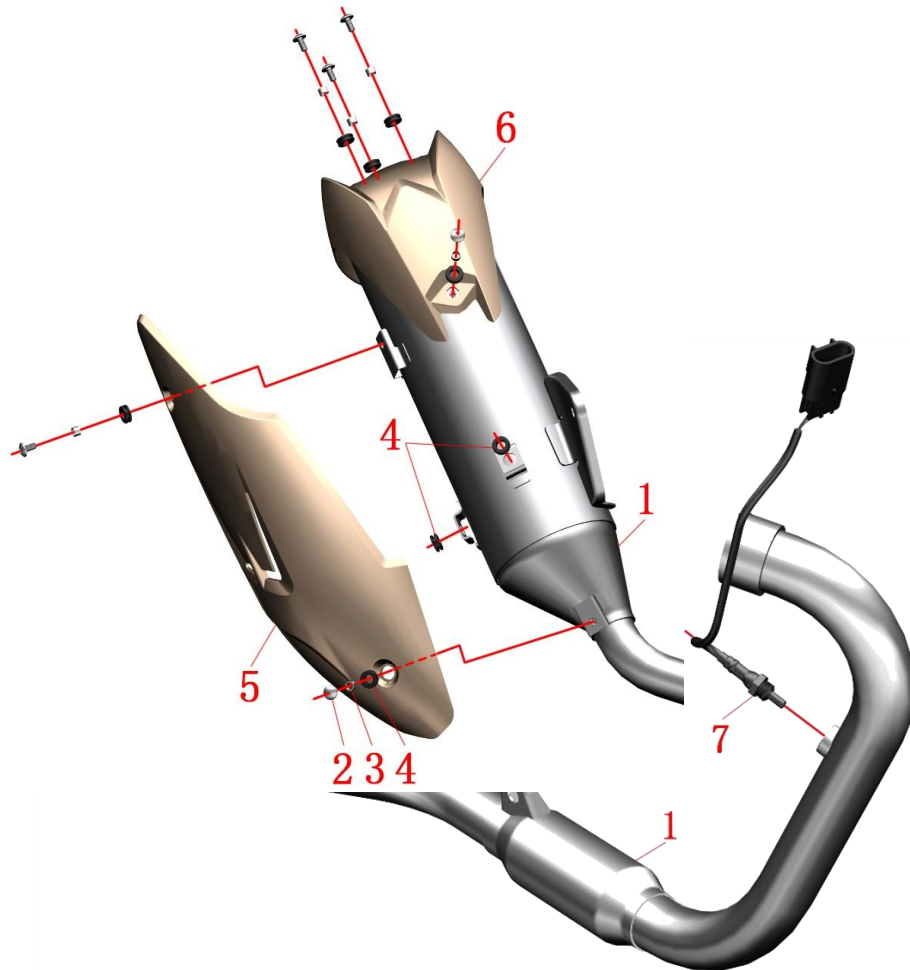

FIG.1 MUFFLER COMPONENT		Muffler component	CHK	CAUTION
NO.	PART NO.	PART NAME	ADJ	
1	1124100-015000	ZT250—R Muffler(Europe IV)	1	
2	1251100-101000	Non-standard bolt M6×12 (304 stainless steel)	6	
3	1274100-018000	ZT250—S Muffler anti-hot plate bushing	6	
4	1246400-317000	ZT368T-G muffler hot plate rubber buffer(5 pcs/after-s)	8	
5	1224100-028000	ZT250—S Muffler anti-hot plate	1	
6	1224100-029000	ZT250—S Muffler tail cover	1	
7	1050953-008000	OSM planar oxygen sensor	1	

PROCEDURE:

- Oxygen sensor
Remove the oxygen sensor (7) with the open spanner.
- Anti-hot plate、 Tail cover
Use the inner hexagonal tool to remove bolt (2), then remove the anti-hot plate (5) and tail cover (6), after that, remove the bushing (3) and rubber buffer (4).

CAUTION:

- Make sure the muffler is completely cooled before operation.
- In the process of disassembly, it should be careful to avoid damaging the material.

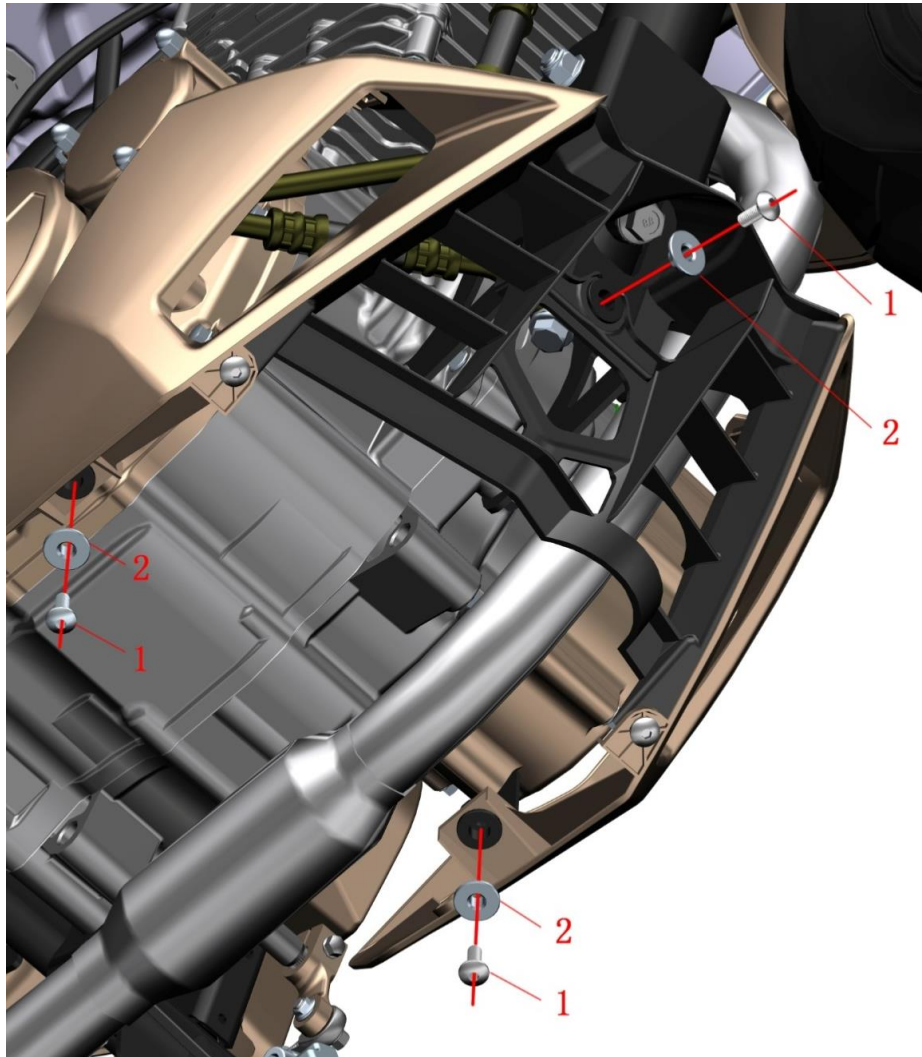

FIG.1 LOWER WIND DEFLECTOR COMPONE		Lower air guide sleeve component-1	CHK	
			ADJ	
NO.	PART NO.	PART NAME	QTY	CAUTION
1	1251100-102000	Non-standard bolt M6×16 (304 stainless steel)	3	
2	1274101-015000	Z1230-S hanging sleeve(φ6.4×φ9×6±φ20×2)(5 pcs/after sale)	3	

PROCEDURE:

- Lower air guide sleeve component

Lift the motorcycle with tools and remove the bolt (1) and flanged bushing (2) with an inner hexagonal tool.

CAUTION:

- In the process of disassembly, the motorcycle should be properly supported to prevent accident caused by incline.
- In the process of disassembly, the lower fairing should be held to prevent fracture caused by unevenly stressed.

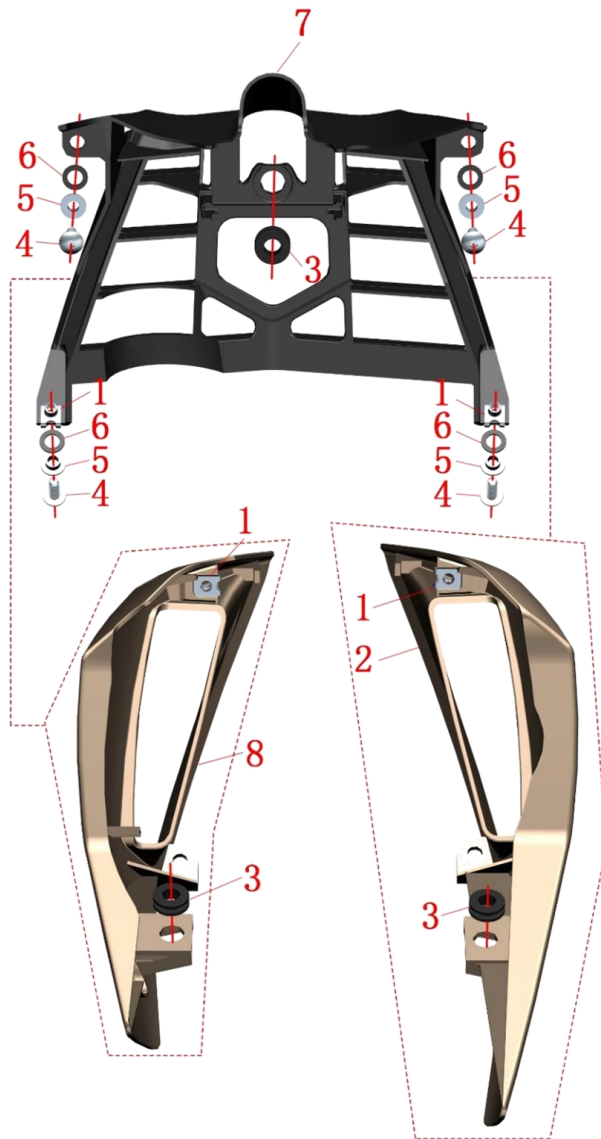

FIG.1 LOWER WIND DEFLECTOR COMPONE		Lower air guide sleeve component-2	CHK	ADJ	CAUTION
NO.	PART NO.	PART NAME	QTY		
1	1251300-063093	Plywood M6×11×15(environmental color)	4		
2	4044100-008051	ZT250—S Right part of lower fairing (titanium)	1	orange	
	4044100-008052	ZT250—S Right part of lower fairing (bright grey)		green&blue	
	4044100-008063	ZT250—S Right part of lower fairing(dark blue)		dark blue	
3	1244100-137000	ZT250-S Flanging bushing buffer(5 pcs/after-sale)	3		
4	1251100-102000	Non-standard bolt M6×16 (304 stainless steel)	7		
5	1274100-155095	Flanged bushing $\phi 6.2 \times \phi 8.4 \times 3.5 + \phi 14 \times 1.5$ (5 pcs/after-	4		
6	1241200-124021	flanging bushing buffer rubber ($\phi 8.5 \times \phi 14 \times 1$)(5 pcs/aft	4		
7	1224100-050000	ZT250—R Middle part of lower fairing	1		
8	4044100-009051	ZT250—S Left part of lower fairing (titanium)	1	orange	
	4044100-009052	ZT250—S Left part of lower fairing (bright grey)		green&blue	
	4044100-009063	ZT250—S Left part of lower fairing (dark blue)		dark blue	

PROCEDURE:

● Lower fairing assembly

Remove the bolt (4) with an inner hexagonal tool and remove the flanged bushing (5) and flanged bushing buffer (6).

Separate lower fairing assembly into three parts.

● Left part of lower fairing

Remove the plywood nut (1) and the flanged bushing buffer (3) from the left part of fairing (8).

● Right part of fairing

Remove the plywood nut (1) and the flanged bushing buffer (3) from the right part of fairing (2).

● Middle part of fairing

Remove the plywood nut (1) and the flanged bushing buffer (3) from the middle part of fairing (7).

CAUTION:

● In the process of disassembly, the fairing should be protected to prevent fracture caused by unevenly stressed or surface scratch.

● Orange use for orange vehicle; green&blue use for bright green&bright blue vehicle; dark blue use for dark blue vehicle.