



ZT310-V (EURO IV/V)

Service manual



2026/04/24

Contents

Table of Contents

	Page
0 Table of Contents	1
1 Frame component	
1.1 Electrical Device component-1	7
Main harness, dump switch, relay, flasher, rectifier, ignition coil	
1.2 Electrical Device component-2	8
Flameout switch, horn, wake-up switch	
1.3 Frame plastic parts.....	9
Set clamp, side cover round glue, fuel tank liner limit glue	
1.4 Directional Column component.....	10
Lower plate component	
1.5 Frame, side bracket, put on the oil operation.....	11
Side bracket, frame oil drain bolt component	
1.6 PKEcomponent (Bosch/colloid battery)	12
2 Frame & engine combination	
2.1 Engine decorative cover components.....	13
Engine left rear cover,right cover decorative	
2.2 Frame & Engine Combination 2.....	14
Hanging piece, bracket component, Lower shroud bracket	
3 Intake system components	
3.1 Intake system components (Delphi EFI).....	15
Throttle valve body component, air filter, oil pipe	
Intake system components (Bosch EFI).....	16
3.2 Carbon canister component.....	17
Carbon canister, canister solenoid valve	
3.3 Air filter filter maintenance	18
3.4 Replace the air filter element 1.....	19
Remove the rear inner board	
3.5 Replace the air filter element 2.....	20
Demolition filter external related parts	
3.6 Replace the air filter element 3.....	21
Remove filter bottom case	
3.7 Replace air filter element 4.....	22
Replace the air filter	
3.8 Replace the air filter element (Bosch) 1.....	23
Remove the rear inner board	
3.9 Replace the air filter element (Bosch) 2.....	24
Demolition filter external related parts	
3.10 Replace the air filter element (Bosch) 3.....	25

Contents

Table of Contents	Page
Remove filter bottom case	
3.11 Replace air filter element (Bosch) 4.....	26
Replace the air filter	
4 Rear wheel and rear fork component	
4.1 Rear auxiliary mud board component 1.....	27
Disassembled rear mud board component	
4.2 Rear auxiliary mud plate component 2.....	28
Sub-mud holder component after discomponent	
4.3 Rear auxiliary mud plate component3.....	29
Sub-mud component after discomponent	
4.4 Rear turn signal after sale parts.....	30
Rear left and right turn signals and rear license plate lights for sale	
4.5 Rear mud board.....	31
4.6 Rear shock absorpction.....	32
Demolition after shock absorpction, rear shock absorpction adjustment	
4.7 Rear wheel component 1.....	33
Remove the rear rim component, sprocket seat, sprocket	
4.8 Rear wheel component 2.....	34
Decomposed rear rim component	
4.9 Rear fork component.....	35
Decomposed flat fork component	
4.10 Replace the rear brake pads.....	36
4.11 Rear brake main pump adds brake fluid.....	37
5 Pedal component	
5.1 Pedal height adjustment.....	38
Shift lever, brake pedal height adjustment	
5.2 Front right pedal mounting position adjustment 1.....	39
5.3 Front right pedal mounting position adjustment 2.....	40
5.4 Front left pedal mounting position adjustment.....	41
5.5 Front right footrest component-3.....	42
Decompose the Front right pedal component	
5.6 Front right pedal after sale parts.....	43
5.7 Shift lever assembly.....	44
5.8 Front left footrest component-3.....	45
Decompose the front left footrest component	
5.9 Front left pedal after sale parts.....	46
Decompose the left footrest component	
5.10 Rear pedal assembly.....	47
5.11 Rear right pedal bracket components.....	48

Contents

Table of Contents	Page
5.12 Rear left pedal bracket components.....	49
6 Cooling system component	
6.1 Change the oil.....	50
6.2 Replace the oil filter.....	51
6.3 Add coolant.....	52
6.4 Radiator covercomponent 1.....	53
Disassemble the radiator covercomponent	
6.5 Radiator covercomponent 2.....	54
6.6 Vice water tank components.....	55
6.7 Radiator tubing component.....	56
Disassemble the radiator tubing component	
6.8 Draining cooling liquid.....	57
Remove the shroud component and release the coolant	
6.9 Main tank component 1.....	58
6.10 Main tank component 2.....	59
Disassemble the main tank component	
7 Front fork component	
7.1 Throttle/clutch cable clearance adjustment.....	60
Adjust the throttle line, clutch cable free travel	
7.2 Light height adjustment.....	61
7.3 Replacement clutch cable.....	62
7.4 Replace the throttle line.....	63
7.5 Steering adjustment.....	64
Adjustment steering device	
7.6 Add brake fluid, rocker adjustment.....	65
Add brake fluid, brake rocker adjustment	
7.7 Replace the front brake pads,front brake caliper mounting plate.....	66
7.8 Front wheel component.....	67
Disassemble the front wheel, front disc brake disc, front axle component	
7.9 Front mud board & wheel speed sensor component.....	68
Decompose front wheel speed sensor component, front mud plate component	
7.10 Headlights assembly 1.....	69
Headlights assembly, cable plug	
7.11 Headlights assembly 2.....	70
Remove headlights	
7.12 Headlights assembly 3.....	71
Remove headlights upper bracket, front turning signal	
7.13 Right hand component.....	72
Remove right rear view mirror, right hand rubber sleeve, balance block, Replace the front brake switch	

Contents

Table of Contents	Page
7.14 Left hand component..... Demolition handle, clamp, instrument component	73
7.15 Directional lever、TFT Instrument..... Demolition handle, clamp, TFT instrument component	74
7.16 Front shock absorber, upper plate component..... Front shock absorber, faucet lock, upper plate component	75
7.17 Uplink plate, direction handle block component..... Disassemble the block, the upper plate	76
7.18 ABS brake system-1..... Remove the control unit protection cover, releasing brake fluid, hydraulic control unit	77
7.19 ABS brake system-2..... Remove the front disc brake main pump and oil pipe	78
7.20 ABS brake system-3..... Remove the front disc brake caliper and tubing	79
7.21 ABS brake system-4..... Disassemble the disc brake main pump and tubing	80
7.22 ABS brake system-5..... Disassemble rear disc brake calipers and tubing, wheel speed sensor	81
8 Fuel tank cover component	
8.1 Fuel tank cover component..... Disassemble the fuel tank cover component	82
8.2 Tank middle cover component..... Decompose the fuel tank cover, fuel tank cover, fuel tank lock	83
8.3 Fuel tank outer cover components..... Disassemble the fuel tank outer cover ,rotating bracket	84
8.4 fuel pump..... Disassemble the fuel pump, fuel tank buffer rubber	85
8.5 Fuel tank front decorative cover..... Disassemble the fuel tank front decorative cover,USB charging cable	86
8.6 fuel tank decorative cover lower part.....	87
8.7 Fuel tank decorative cover components 1.....	88
8.8 fuel tank decorative cover components 2.....	89
9 Side cover component	
9.1 Side cover component..... Decomposition side cover component	90
10 guard bar sembly	
10.1 Guard bar assembly 1..... Disassemble the guard bar outer parts	91

Contents

Table of Contents	Page
10.2 Guard bar assembly 2..... Disassemble left and right guard components	92
10.3 guard bar assembly 3..... Disassemble the left and right guard bar components	93
10.4 Engine decorative cover components..... Disassemble the engine decorative cover	94
11 Rear cover component	
11.1 Electric device box cover component Disassemble the electric device box cover,battery,Charging port and charging precautions	95
11.2 Electrical device box component (colloid battery).....	96
11.3 Backrest assembly component..... Disassemble the backrest,Backrest rubber	97
11.4 Tail skirt taillight component 1..... Disassemble PKE single antenna, buzzer	98
11.5 Tail skirt taillight component 2..... Disassemble the tail skirt left and right decorative cover,decorative cover bracket	99
11.6 Tail skirt taillight component 3..... Disassemble the rear aluminum alloy bracket	100
11.7 Tail skirt taillight component 4..... Rear skirt taillight component	101
11.8 Electrical device box component..... Disassembled device box component,PKE controller	102
11.9 External battery to start PKE system..... Emergency method to turn on PKE after battery power is exhausted	103
12 Cushion component	
12.1 cushion..... Discomponent and component cushion; seat cushion rubber separately purchased parts	104
13 Muffler component	
13.1 Muffler component 1..... Disassemble the muffler peripheral components	105
13.2 Muffler component 2..... Disassemble the front left pedal bracket components,Muffler components left side mounting position	106
13.3 Muffler component 3..... Disassemble the muffler components, oxygen sensor	107
13.4 Muffler component 4..... Disassemble the muffler decorative cover	108
14 Lower shroud component	

Contents

Table of Contents	Page
14.1 Lower shroud component-1..... Remove the shroud component, shroud bracket	109
14.2 Lower shroud component-2..... Decompose the lower shroud component	110

All the information, illustrations and photographs collected in this manual are compiled according to the latest products. However, there may be some inconsistencies between your motorcycle and this manual due to the continuous improvement of the product and other changes. For colors or upgrades, please refer to the part codes on the official website. This manual will not be listed in detail; if the part names in this manual are inconsistent with the official website, the official website shall prevail.

©Guangdong Tayo Motorcycle Technolog Co.
Ltd All rights reserve

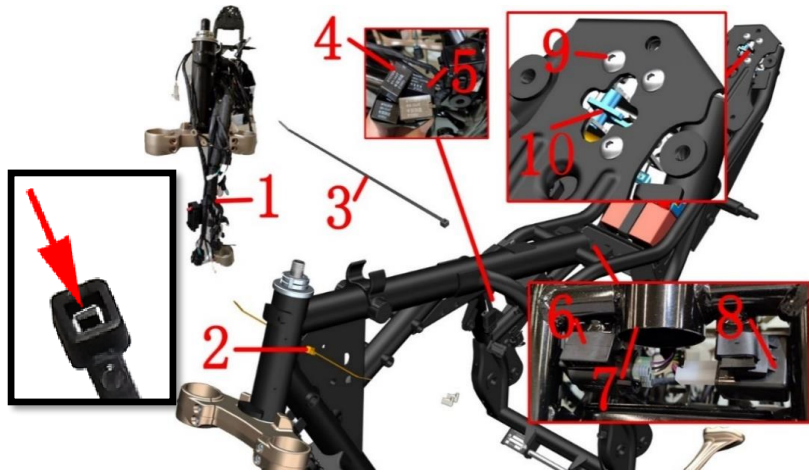

Fig.1 FRAME&ELECTRONIC PARTS COMPONENT		Electronic parts COMPONENT-1	CHK	⚠
			ADJ	
NO.	PART NO.	PART NAME	QTY	CAUTION
1	1184200-082000	ZT310-V harness components	1	
	1184200-169000	ZT310-V wiring harness assembly (Bosch)		
2	1224100-030000	Plug cable tie (black 4.8×130)	2	
3	1226000-218000	Grade 0 frame retardant tie (black 3.6×295)(5 pos/after sale)	9	
4	1186001-018000	ZT250-S Four-pin Normally Open Relay(after-sale)	3	KH-1A4T
5	1184200-024000	ZT310-R side stand relay	1	G8HN-1C4T-RJ
6	1244100-082000	ZT250-S Dump switch rubber	1	
7	1184100-002000	ZT250-S Dump switch	1	
8		Flasher	1	
9	1251100-101000	Non-standard bolt M6×12 (304 stainless steel)	5	
10	1274100-058000	ZT310 seat lock	1	
11	1251100-102000	Non-standard bolt M6×16 (304 stainless steel)	3	
12	1050954-019000	MT05.2 engine controller size ZT310-RC4	1	ECU
13	1184300-002000	ZT350 starting relay	1	
14	1274200-171000	ZT310-V relay bracket	1	
15	1274200-162000	ZT310-V fuse box bracket	1	
16	1251300-207000	Non-standard cover type 9 degree nut M6×15 (environmental color Zinc)(5 pos/after sale)	2	Bosch EFI
17	1050954-037000	MSE6.0 Controller-ZT180MN (Euro 5)	1	
18	1274200-268000	ZT310-VX Bosch ECU bracket	1	

PROCEDURE:

●Flasher and dump switch

Remove the rubber sleeve (8) that connects the flasher (6) to the mounting bracket on the frame, and remove the dump switch with the same method, then separate the dump switch (7). Locate the main harness rubber sleeve on the right side of the frame, pull out the rubber sleeve, pull out the side bracket relay (5) and the EFI relay (4). Locate the starter relay (13) above the air filter to remove the sheath of the harness and remove the self-contained nut to remove the relay from the relay bracket (14). Disassemble the bracket(14) after removing the bolt(11). Remove the bolt (11) after removing the engine controller plug (12) on the left side.

●Seat lock

Take off the plug of the seat lock, and cut off binding (3). Remove bolts (9), then remove the seat lock (10).

●Main harness

Find the fuse box on the right side of the right air filter pull it up from the fuse box bracket(15), then remove the bolt(9), take off the fuse box bracket(15). Different plug-in methods are different, please unplug all the electrical components connected to the main thread according to the actual operation. It needs to use a word screwdriver, forceps, scissors and other tools to assist. The binding (3) can be picked out by using scissors.

The plug strap (2) is a non-detachable structure and it is not recommended to cut it directly. It is difficult to remove the broken portion of the buckle that is forcibly removed from the frame triangular reinforcing plate.

CAUTION:

●Please notice the limit of the bracket when dismantling flasher and dump switch sleeve, beware of hurting your fingers.

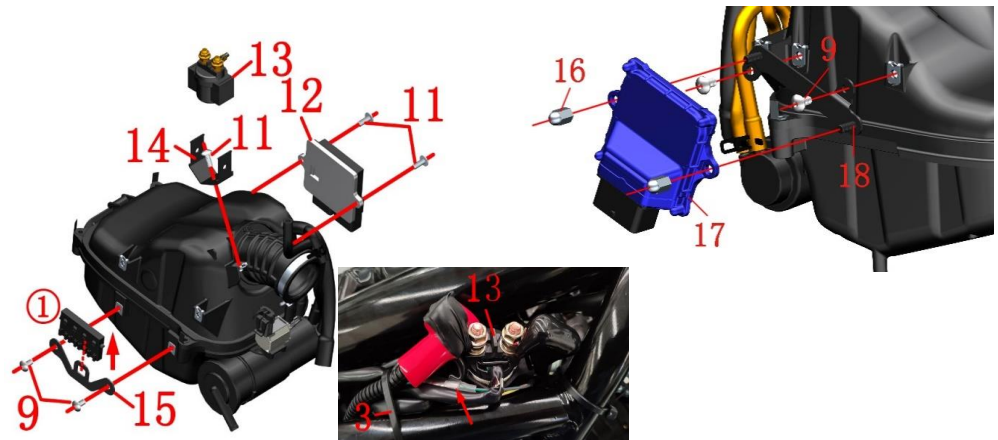



Fig.2 FRAME&ELECTRONIC PARTS COMPONENT		Electronic parts COMPONENT-2		CHK	CAUTION
NO.	PART NO.	PART NAME	QTY	ADJ	
1	1251100-061093	M6×22 Screw bolt	2		
2	1274200-033000	ZT310—R No.2 holder of front disc oil pipe	1		
3	1184200-004000	ZT310 Horn	1		
4	1274100-017000	ZT250—S Cable clip	2		
5	1226000-218000	Grade 0 flame retardant tie (black 3.6×295)(3 pcs/after sale)	2		
6	1274100-095000	ZT250—S Holder of flameout switch cable	1		
7	1184100-012000	ZT250—S Flameout switch	1		
8	1250205-040095	GB70.1M8×16 Screw	2		
9	1251112-001093	M6×16 Hexagon flange bolts (color zinc)	1		
10	1274200-183000	ZT310-V outlet pipe bracket	1		
11	1184200-033000	ZT310—R Rectifier (Lithium)	1		【1】
	1184200-133000	ZT310 Rectifier (230W)			
	1184200-174000	ZT310 rectifier (five wire)			
12	1274200-141000	ZT310-V high voltage package bracket	1		
13	1251100-101000	Non-standard bolt M6×12 (304 stainless steel)	1		
14	1184200-108000	ZT310 EFI ignition coil	1		Old
	1184200-104007	ZT310 EFI ignition coil (with high voltage line)			
	1184200-177000	ZT310 EFI ignition coil (with high-voltage wire/with damping wire)			New
15	1250201-032093	GB818M5×16 bolt	2		
16	1050954-017000	LDK8RTIP—0.8 sparking plug	1		

PROCEDURE:

- Horn
Take off the plug of horn① take the horn (3) by one hand use tool rotate the screw (1) by another hand remove the holder(2) then take off the horn.
- Flameout switch
Find and take off the plug of the flameout switch (6) press and take off the cable clip (4) cut ribbon(5). Using the inner hexagon tool, remove the bolts (8)、the holder (6) and the flameout switch (7) .
- Rectifier
Find and remove the rectifier plug, remove the bolt (1), remove the outlet pipe bracket(10); remove the bolt (9) and remove the rectifier (11). Note that the rectifier is not universal.
- Ignition coil
First remove the oxygen sensor cable tie from the high pressure package bracket (12). Then pull out the metal shield cap of the ignition coil (14) from the spark plug (16) on the engine, and then remove the bolt(15) with a Phillips screwdriver to remove the coil (14). Remove the bolt (13) and remove the high pressure package bracket (12).



CAUTION:

- The ignition coil needs to distinguish whether it has a high voltage line. If your vehicle uses an ignition coil without a high-voltage line, you must replace the main wiring harness with an ignition coil with a high-voltage line.
- 【1】 The back of rectifier printed "ZT310(230W)" for the large magnetic motor version.

Fig.3 FRAME&ELECTRONIC PARTS COMPONENT		Frame plastic parts	CHK	
NO.	PART NO.	PART NAME	ADJ	
1	1224100-030000	Plug strap (black 4.8×130)	2	CAUTION
2	1244100-019000	ZT250—S Inner fuel tank fix glue cushion	1	
3	1244100-138000	ZT250-S Side cover round rubber(5 pcs/after-sale)	6	
4	1241200-125000	HJ125-6 Battery rubber gasket(5 pcs/after-sale)	1	
5	1244100-061000	ZT250 Frame water proof rubber plug	2	
6	1251100-101000	Non-standard bolt M6×12 (304 stainless steel)	1	
7	1224200-205000	ZT310 electronic cushion lock guide block	1	

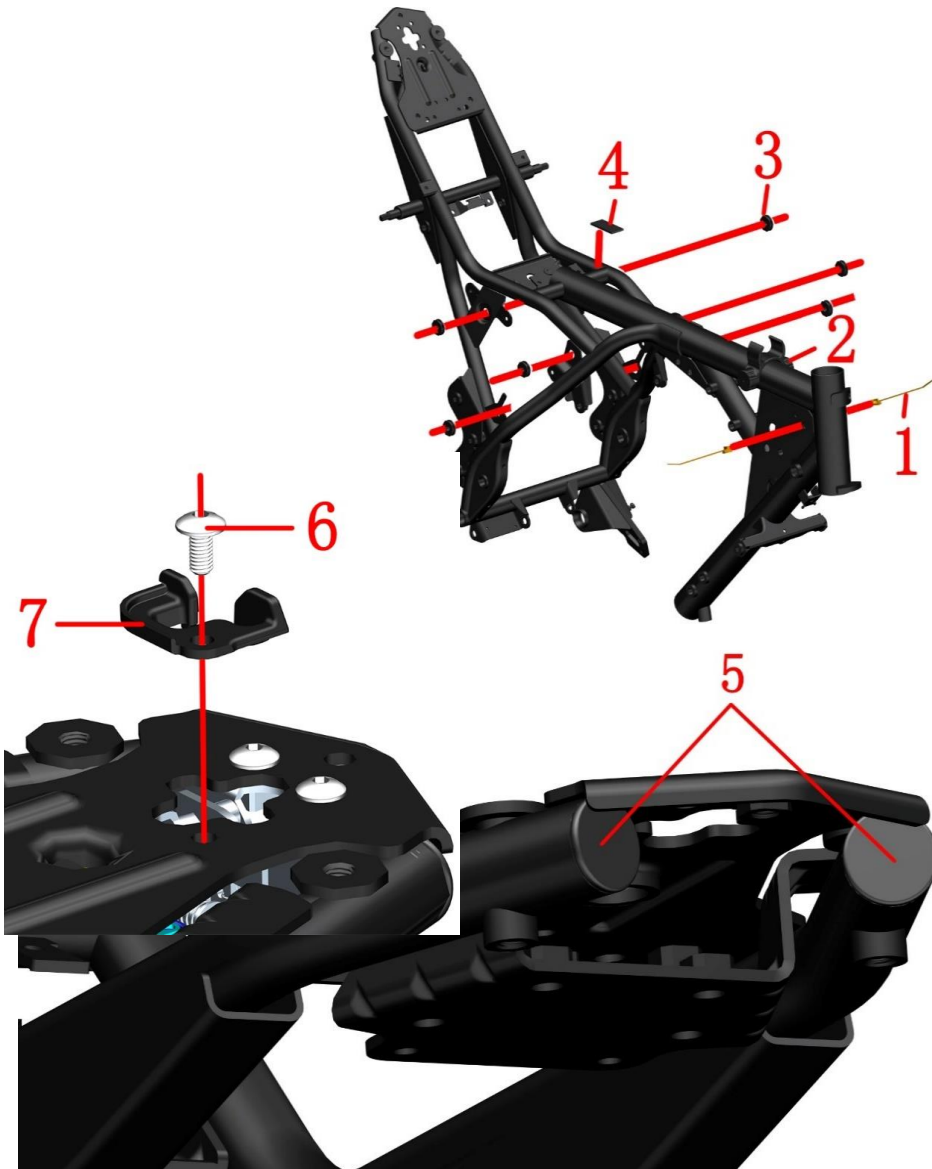

PROCEDURE:

● Inner fuel tank fix glue cushion

Use both hands to hold the two ends cylinder parts of the inner fuel tank limited glue cushion (2) and should push it out.

● Side cover cushion

Remove the side cover cushion (3) with your hand directly.

● Battery cushion

Put off the battery cushion (4) directly by hand.

● Frame waterproof rubber plug

Remove the frame waterproof rubber plug (5) with your hand directly.

CAUTION:

● It must be dismantled them first, such as the cushion, fuel tank cover, inner fuel tank, sider cover, tail dress and so on.

● All parts should be correctly assembled.

● From October 22, 2020, one guide block(7) have been added to the electronic cushion lock.

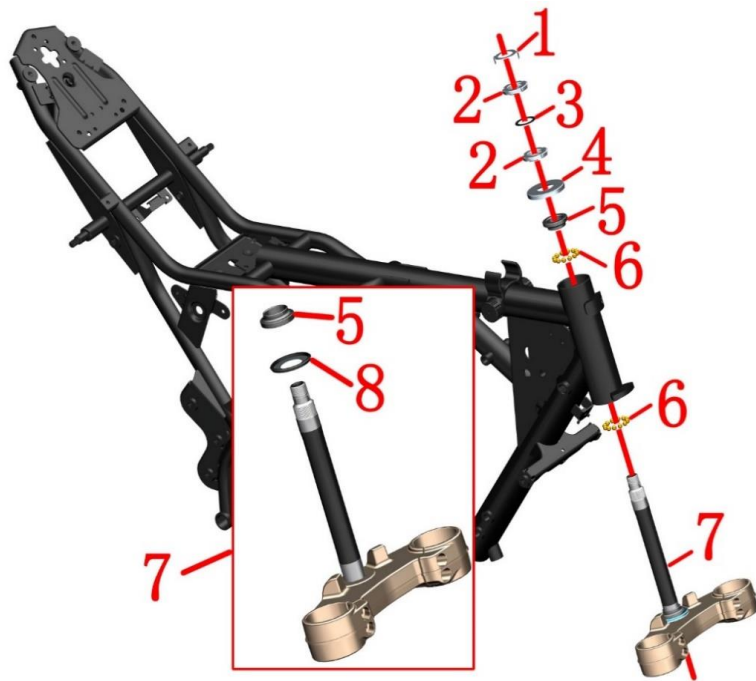

PROCEDURE:

● Disassembly

Remove the lock washer (1).

Remove the top adjusting nut (2) by using a special four-jaw or hook wrench tools.

Remove the rubber pad (3).

With one hand to hold down the down connected plate assembly (7), the other hand use a special four-jaw set or hook wrench to remove the adjusting nut (2).

Remove the upper dustproof cover (4). Remove the down connected plate component (7).

Remove the axle ring (5) of the upper riser and the steel ball (6).

Remove the steel ball of the down connected plate component (7).

● Assemble

When reassembling, the conjoined steel beads should be painted lubricating grease, attention to the dosage.

The torque of rating nut which closes to upper dustproof cover is required to about 14N.m so as to be able to rotate out of nimbleness.

The top adjusting nut only needs to rotate to the bottom of the nut groove alignment, not too tight to prevent the rubber pad (3) from deformation too large.

Fig.4 FRAME&ELECTRONIC PARTS COMPONENT		Steering rack component		CHK	CAUTION
NO.	PART NO.	PART NAME	QTY	ADJ	
1	1134100-040000	ZT250-S Adjusting nut locking washer(5 pcs/after-sale)	1		
2	1251300-046093	ZT250-S Steering column rating nut (color zinc)	2		
3	1244100-135000	ZT250-S Adjusting nut rubber gasket (5 pcs/after-sale)	1		
4	1244300-014000	ZT350-R upper dust cover	1		
5	1130900-053000	ZT250-S shaft ring (after-sale)	1		
6	1130900-054000	ZT250-S conjoined steel ball (5 pcs/after-sale)	2		
7	1134100-015000	ZT250-S Down connected plate (selfmade/with blowout patch) component	1		
8	1224100-006000	ZT250-S Steering column down dustproof cover	1		【1】

CAUTION:

● Remove the head part component, handlebar component and front shock absorber component first.

● Please pay attention to fix the awaiting repair motorcycles during disassembly, prevent dumping by accident.

● Please check whether the steel beads of the conjoined body have abnormal phenomena such as partial abrasion and rust. If YES, please buy the regular accessories on ZONTES official website, if not, please be sure to grease the old grease and repaint the lubricating grease on it.

● It must be to check whether the steel ball is available during reassembly.

● It must be reasonable to adjust the steering, too loose will cause the locomotive to brake slightly, and the locomotive will shake slightly, too tight can lead to inflexibility, resulting in safety hazards.

● If you have the ability and the right tool, you can change the shaft ring (5) and the dustproof cover (8). During the replacement process, pay attention to the protection of the lower connected plate. After replacement, it must be to check the parallelism of the column and the damping hole, the vertical degree of the vertical column and the lower connected plate.

● 【1】 the down connected plate (selfmade/with blowout patch) component (7), has been contains the Steering column down dustproof cover (8).

**CAUTION:**

- Remove the wind deflector component, handle bar component, steering column component first.
- Paint the lubricating grease on the cushion ring to decrease the rotary resistance of front forklift.
- The waste oil needs to be collected and returned to qualified institutions. It is forbidden to dump and pollute the environment and the source of water.
- Pay attention to safety when mounting side support spring.
- All parts should be correctly assembled.

Fig.5 FRAME&ELECTRONIC PARTS COMPONENT		Frame, Side support, the operation of releasing engine oil	CHK	⚠
			ADJ	
NO.	PART NO.	PART NAME	QTY	CAUTION
1	4014200-023000	ZT310-V frame after-sales assembly Euro IV (including fix loop / nameplate)	1	Domestic
	4014200-028000	ZT310-V2 frame assembly (for after-sale) (including seat ring/nameplate/Euro V)		
2	1130900-052000	ZT250-S upper steel bowl (after-sale)	2	after-sale
3	1274100-006000	ZT250-S Frame engine oil filter screen	1	
4	1051453-003000	27.4×2.65 Acrylate O gule cushion loop	1	
5	1274100-024000	ZT250-S Oil cooling joint	1	50±4N.m
6	1244100-033000	Sealing gasketφ12×φ20×2	1	
7	1251100-066093	M12×1.5×15 Ablassschraube (color zinc)	1	24±4N.m
8	1251300-057093	Non-standard bolt M10×1.5 (dacromet)	1	45±5N.m
9	1251700-025091	ZT250-S Side support bush	1	
10	1274200-200000	ZT310-T side support(short)	1	
	1271200-165000	ZT310-T side bracket (short/dark gray)		
11	1251100-088094	Non-standard bol M10×1.5×43 (dacromet)	1	
12	1260300-079093	ZT250-S side stand spring(after-sale)	1	

PROCEDURE:

● Checking the cushion loop

Checking whether the cushion loop (2) is frayed, if as it, please replace it on ZONTES website, fix the cushion loop well and paint the lubricating grease on it with appropriate tool.

● Replacing the engine oil filter screen

Put the oil pan on the bottom and use the appropriate tools to remove the oil cold joint (5), O ring (4), and oil filter screen (3). When replacing the oil filter screen (3), the O-ring (4) must be replaced at the same time. The oil cooling joint (5) must be tightened well when re-assembling which meets the standard torque value.

● Realease the frame tube enging oil

Put the oil pan at the bottom, use the appropriate tool to remove the oil bolts (7) and the sealing gasket (6), and remove the oil from the frame tube. Refer to the instructions for detailed steps to replace the oil. It is recommended that the engine oil should be replaced with oil bolts (7) and sealing gasket(6) to prevent oil leakage.

● Sider support

Use the cross screwdriver to remove the side support spring, and guard against the personal injury caused by spring contraction, remove the nuts (8) and bolts (11) with the appropriate tools. Remove the side support (10) and bush (9), paint the lubricating grease on the bush(9) when re-assembling ,then put it into the frame (1).

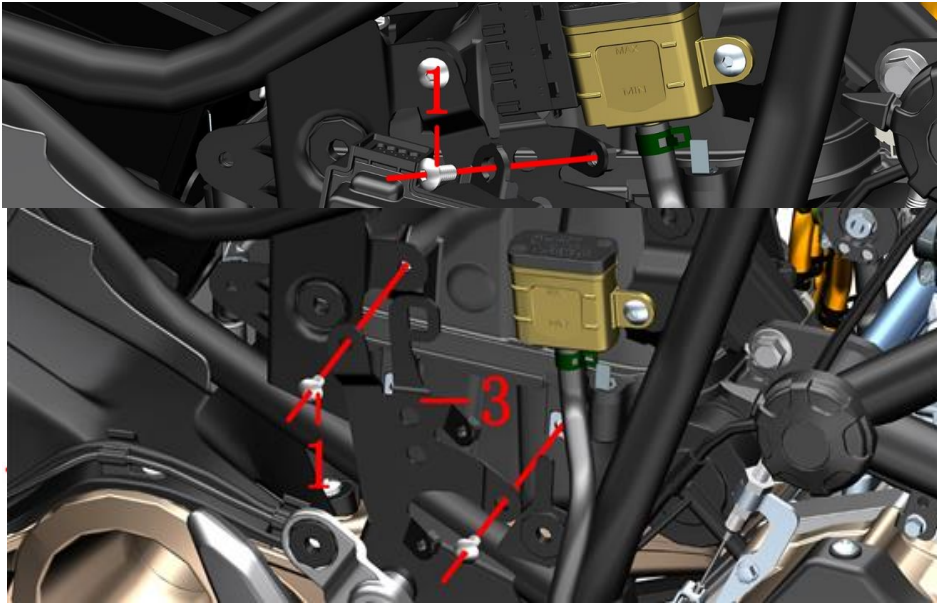

Fig.6 FRAME&ELECTRONIC PARTS COMPONENT		PKE component (Bosch/colloid battery)	CHK	⚠
			ADJ	
NO.	PART NO.	PART NAME	QTY	CAUTION
1	1251100-101000	Non-standard bolt M6×12 (304 stainless steel)	4	
2	1184200-137000	ZT310 PKE Controller (bracelet edition)	1	
3	1274200-271000	ZT310—V1 PKE holder	1	
4	1244200-132000	ZT310PKE rubber sleeve	1	

PROCEDURE:

●PKE Controller

Unplug the PKE plug, use a No. 4 allen wrench to remove the two bolts (1) to remove the PKE assembly (2) and ZT310PKE rubber sleeve(4);

●PKE bracket

Use a No. 4 allen wrench to remove two bolts (1) to remove the PKE bracket (3);

●Fuse

Remove the PKE fuse, check whether it is blown, if it is blown, replace the fuse of the same specification.

The band version of the PKE assembly uses 2 small 15A fuses.

●Charging

Turn on the dustproof glue of the PKE charging port, and plug the charger into the charging port for charging. If the charger indicator shows red, it means charging, and green means fully charged.

CAUTION:

●When inserting and pulling out the fuse, please pay attention to the vertical alignment before disassembly, and it is strictly prohibited to bend. A qualified fuse should be used.

●PKE cables need to be protected. Non-professionals are strictly prohibited to disassemble the PKE system components, otherwise it may cause permanent damage.

●Please refer to the driver's manual for PKE operating instructions.

●Be careful not to overcharge the charging time. Please refer to the manual for details on battery usage and maintenance.

●The button battery model used in the band version: CR1225.

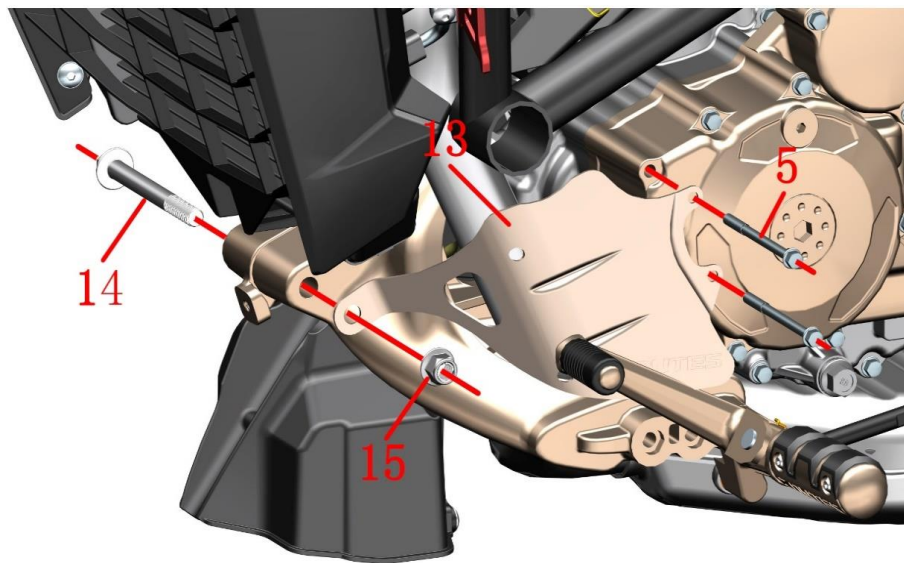
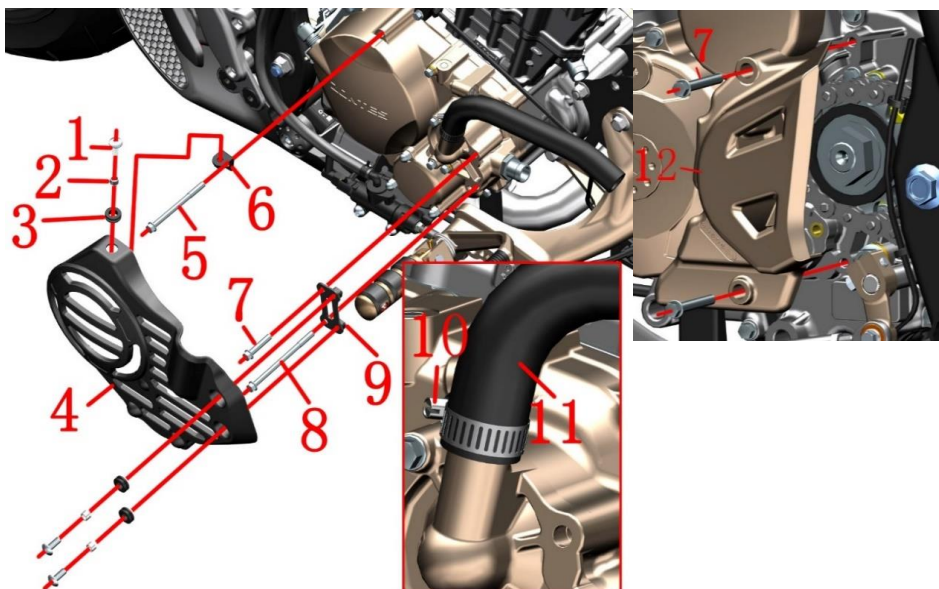

PIC.1 FRAME&ENGINE		ENGINE TRIM COVER ASSY	CHK	⚠
			ADJ	
NO.	PART NO.	PART NAME	QTY	CAUTION
1	1251100-102000	Non-standard bolt M6×16 (304 stainless steel)	3	
2	1274100-018000	ZT250—S muffler anti-scald plate bushing	3	
3	1244100-017000	ZT250—S muffler anti-scald plate rubber	3	
4	1224200-157000	ZT310—V Trim cover of right engine cover	1	
5	1251112-005093	M6×75 hexagon flange bolt (color zinc)	3	10N.m
6	1274200-221000	ZT310—V Mount bracket of engine right trim cover	1	
7	1251112-003093	M6×45 hexagon flange face 9.8 bolt (color zinc)	3	10N.m
8	1251112-006093	M6×90 hexagon flange bolt (color zinc)	1	10N.m
9	1274200-220000	Front mount bracket of engine right trim cover	1	
10	1276001-055000	ZT310 Water pipe clamp (φ26)(after-sale)	1	
11	1244200-068000	ZT310—V Engine water inlet pipe	1	
12	4044201-022051	ZT310—R Rear left cover of engine	1	
	4050854-002051	ZT310-R engine left rear cover (dark gray)		
13	4024200-058035	ZT310-V Muffler Left Anti-scalding Plate (Titanium)	1	
14	1251100-135000	Non-standard bolt M10×1.5×95 (dacromet)	1	
15	1251300-057093	Non-standard nut M10×1.5 (dacromet)	1	65±5N.m

PROCEDURE:

● Engine right trim cover assembly

Disassemble 3 bolts (1) and take out the right trim cover components. Remove the bushing (2)、buffer rubber (3) from the right trim cover components. Disassemble the bolts (7)、(8) and take out the bracket (9). Use a screwdriver to loosen clamp (10), unplug the water inlet pipe (11)

● Engine left rear cover

Remove the bolt (7) disassemble the rear cover (12).

● Anti-scald left muffler plate

Remove the lower shroud assembly first. Secure the head of the bolt (14) with a sleeve and remove the nut (15). Grab the anti-scalding plate (13) and remove the 2 bolts (5) to remove it.

CAUTION:

- Engine right trim cover is only suitable for sliding clutch engine.
- The coolant should be drained before disassembly.
- Swallowing or inhaling the coolant can be harmful to the human body. Please thoroughly clean any exposed skin such as hands, face, etc. after each addition of coolant. Contact poison control center or hospital immediately if swallowed. If inhaled, please go to a ventilated environment immediately. In case of accidental splash into eyes, please immediately flush eyes with plenty of running water and seek medical treatment in time. Be sure to stay away from children and pets.
- The total amount of coolant (ZT310-V) is 1580ml. More details in Product Manual.
- Early production of the motorcycle does not include a left muffler anti-hot plate, may install your own.

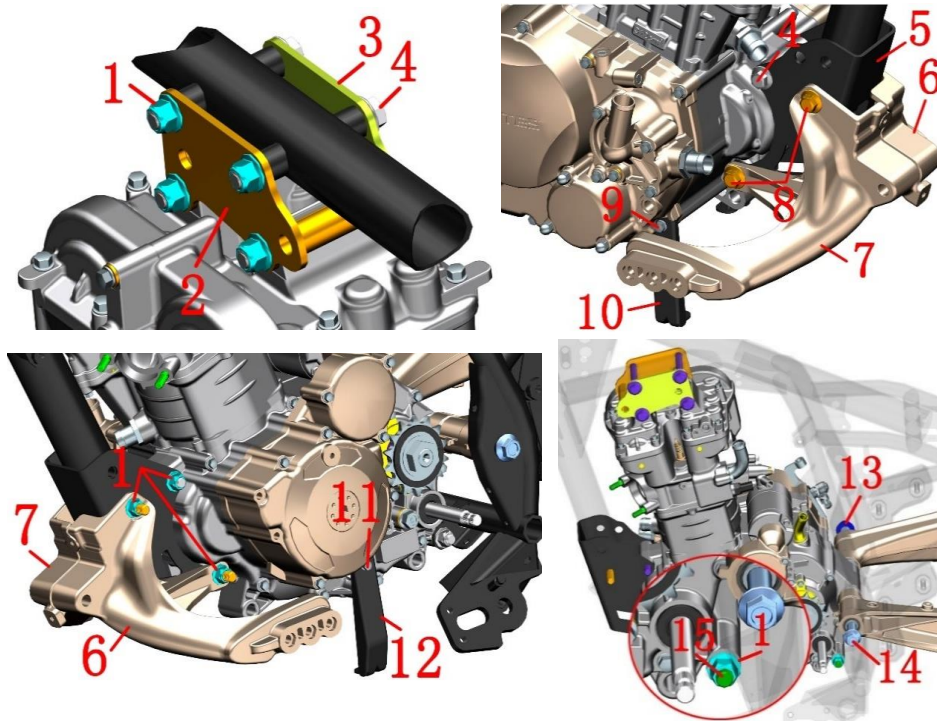

CAUTION:

● It is necessary to remove the seat cushion, fuel tank, side cover, pedal support, wind deflector, shift lever, muffler, radiator and pipe, cable, air filter joint, chain, engine start motor positive line pole, etc.

● There are four versions of hanging pieces which can be universal to each other. 【2】 there are two versions of 4-hole as shown in FIG. a and 5-hole as shown in FIG. b. 4 holes have no stock, 5 holes are depleting stock; when all stock are sold, it will be unified into 【3】, as shown in FIG. e. 【1】 was produced from January to mid-april 2019 as shown in FIG. c and d. From the middle of April to August 15, 2019, the hanging pieces with 4 holes 【2】. Since August 15, the five-hole hanging pieces have been consumed 【2】.

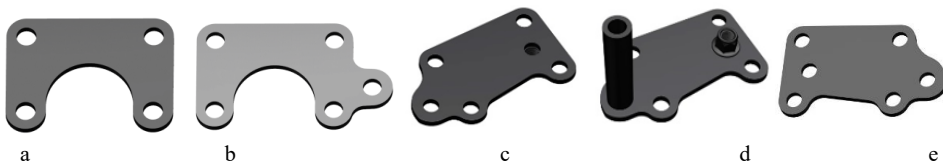

Fig.2 FRAME&ENGINE		FRAME&ENGINE	CHK	⚠
NO.	PART NO.	PART NAME	ADJ	
1	1251300-057093	Non-standard nut M10×1.5	QTY	CAUTION
2	1020242-185000	ZT310—R Left hanging piece	8	65±5N.m
3	1020242-186000	ZT310—R Right hanging piece	1	【1】
4	1251100-132003	Non-standard bolt M10×1.5×80	1	
5	4024200-043000	ZT310—V bracket	5	
6	1274200-092000	ZT310—V front bracket of left footrest	1	
7	1274200-093000	ZT310—V front bracket of right footrest	1	
8	1251100-137000	Non-standard bolt M10×1.5×100	1	
9	1251112-003093	M6×45 hexagon flange face 9.8 bolt	2	12±1.5N.m
10	1274200-131000	ZT310—V right support of upper wind fairing	1	
11	1251112-005093	M6×75 hexagon flange bolt	1	12±1.5N.m
12	1274200-130000	ZT310—V left support of lower wind fairing	1	
13	1251300-059093	125 rear fork screw M14×1.5	1	110±5N.m
14	1252200-032000	ZT310—VRear forklift axle	1	
15	1251100-086093	Non-standard bolt M10×1.5×112	1	
16	1020241-225000	ZT250—R upper hanging piece	2	【2】
17	1020242-385000	ZT310—V Upper hanging piece		【3】

PROCEDURE:

● Front footrest bracket, wind fairing bracket

Fix the heads of the bolts (8) with the sleeves, and disassemble the two nuts (1) on the left side respectively. Remove the front left footrest bracket (6), then hold the front right footrest bracket (7), disassemble the bolts (8) and take out the right footrest bracket. Disassemble the bolt (11), the left bracket (12), the bolt (9), and the right bracket (10).

● The middle part of the engine is connected with the frame and the rear fork

Fix the head of the bolt (15) at the lower part of the engine and the frame, and disassemble the nut (1). Only disassemble the nut and other parts cannot be disassembled.

First fix the bolt (4) head at the hanging piece with a sleeve, then remove the nut (1). The bolts, the upper right hanging piece and the upper left hanging piece cannot be removed.

● Disassemble the engine

First fix the head of the rear fork shaft (14) with a sleeve, and disassemble the nut (13). One person shakes the rear fork assembly slightly and one pulls the rear fork shaft (14). Both of them hold the engine left and right crankcase at the same time; one person disassembles the bolts (4), hanging pieces (2), (3) or take out the hanging piece (16). Disassemble the bolts and brackets (5) above the front bracket. Hold the engine to move to one side and pay attention to safety during the movement. Place the engine smoothly on the ground.

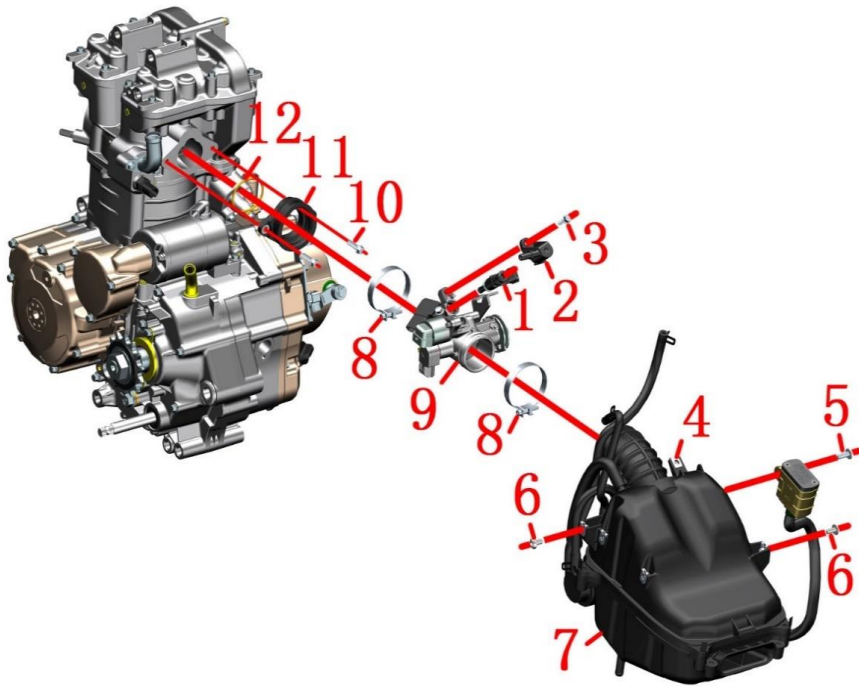



FIG.1 INTAKE SYSTEM COMPONENT		Intake system component(Delphi EFI)	CHK	
NO.	PART NO.		ADJ	
1	1050954-007000	39-N008 Fuel injector	1	
2	1050954-008000	39-N008 Fuel injector fixator	1	
3	1251112-001093	M6×16 Hexagon flange bolt (color zinc)	1	
4	1251300-063093	Plywood M6×11×15 (Environmental protection)	8	
5	1251100-102000	Non-standard bolt M6×16 (304stainless steel)	1	
6	1251100-101000	Non-standard bolt M6×12 (304stainless steel)	2	
7	1224200-129000	ZT310-V air filter	1	
8	1051354-004000	Φ56×10 Hoop assembly	2	
9	1050954-005000	TB39 Throttle body part	1	
10	1251100-061093	M6×22 Hexagon flange bolt (color zinc)	2	
11	1050954-012000	TB39 Intake pipe assembly	1	
12	1051453-007000	45×2.1 Fluorine rubber O-ring	1	

PROCEDURE:

● Air filter

Remove bolt (5)、(6); loosen the pipe hoop assembly (8) against the end of the air filter, clamp the hoop on the exhaust pipe with pliers and unplug the exhaust pipe connected to the exhaust port of the engine, and then use the rubber plug supplied with the car to prevent foreign bodies from entering the engine. Remove the empty filter assembly, splint nut (5).

● Throttle assembly

Use the plum blossom wrench to loosen the bolt (10), and remove the throttle assembly. Loosen the hoop (8) between the intake pipe assembly (11) and throttle assembly (9), and then remove them separately. Remove the O-ring (12) from the intake pipe assembly. Loosen the bolt (2) on the injector holder (3) with a sleeve. Remove the holder and remove the injector (1).

CAUTION:

● First it need to remove the cushion, side cover, oil tank outside cover and liner, rear shock absorber and electrical device box etc.

● Before reassembly, check the O-ring (12) for damage and replace it if any.

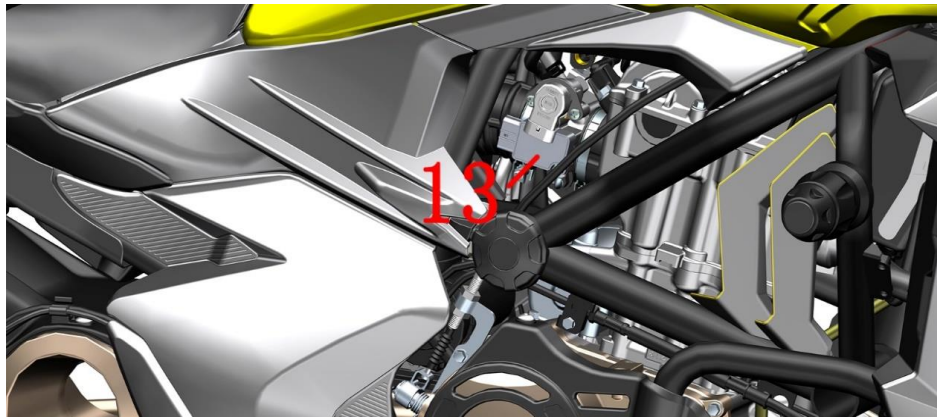
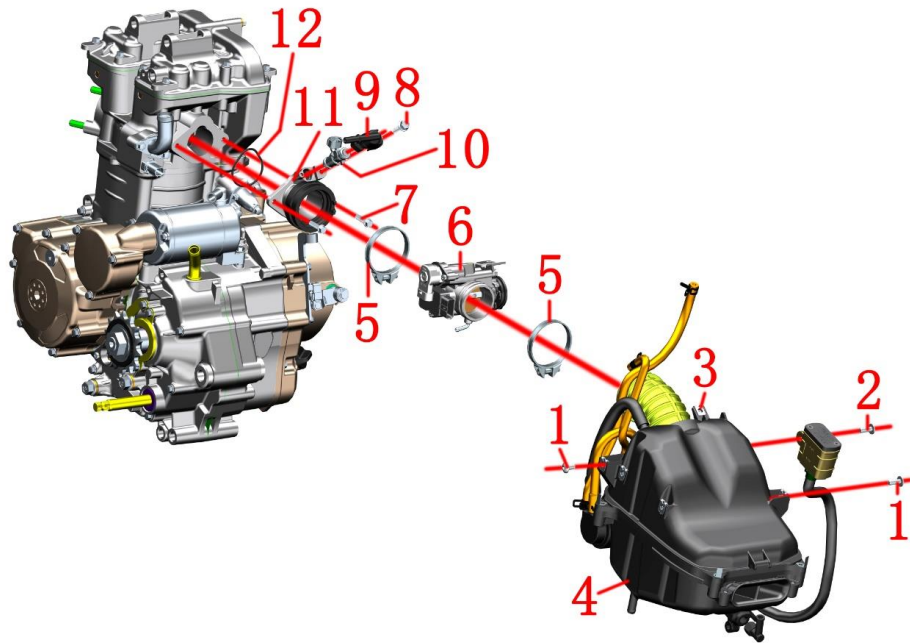

FIG.2 INTAKE SYSTEM COMPONENT		Intake system components (Bosch EFI)	CHK	
NO.	PART NO.		ADJ	
		PART NAME	QTY	
1	1251100-101000	Non-standard bolt M6×12 (304 stainless steel)	2	
2	1251100-102000	Non-standard bolt M6×16 (304 stainless steel)	1	
3	1251300-063093	Clamp plate M6×11×15 (environmental color)	8	
4	1224200-170000	ZT310-V1 Air filter (Bosch)	1	
5	1051354-004000	Φ56×10 pipe clamp assembly	2	
6	1050954-038000	ZT40 three-in-one valve body sub-assembly manufacturing parts	1	
7	1251100-061093	M6×22 Hexagon flange bolts (Class 8.8/Environmental Protection Color Zinc)	2	
8	1250105-138093	GB5789M6×20 (environmental color)	1	
9	1050968-002000	ZT1P58MJ injector retainer	1	
10	1050954-023000	EV14 injector G48	1	
11	1050954-034000	ZT180MN intake pipe assembly (Bosch)	1	
12	1051454-016000	45×2.5 fluorine rubber O-ring	1	
13	1050954-042000	ZT40 three-in-one valve body(right motor) sub-assembly manufacturing parts	1	

PROCEDURE:

● Air filter

Remove the bolts (1), (2),(4); loosen the hose clamp assembly (5) on the side of the air filter, clamp the clamp on the exhaust pipe with pliers and pull out the exhaust pipe connected to the exhaust port of the engine, and then use the rubber plug that was delivered with the bike. Plug it well to prevent foreign matter from entering and damaging the engine. Remove the air filter assembly and splint nut (3).

● Throttle valve assembly

Use a wrench to remove the bolt (7) and remove the throttle valve assembly. Loosen the pipe clamp (5) between the intake pipe assembly (11) and the throttle valve component (6), and remove them respectively. Remove the O-ring (12) from the intake pipe assembly. Remove the bolt (8) that fixes the injector holder (9) to remove the holder, and remove the injector (10).

CAUTION:

● First it need to remove the cushion,side cover,oil tank outside cover and liner,rear shock absorber and electrical device box etc.

● Before reassembly, check the O-ring (12) for damage and replace it if any.

● The valve(6) and (13) can not be universal,the corresponding throttle line is also different need to pay attention to distinguish.Through the throttle line tumtable in the motorcycle forward direction of hte left or rihgt to distinguish.

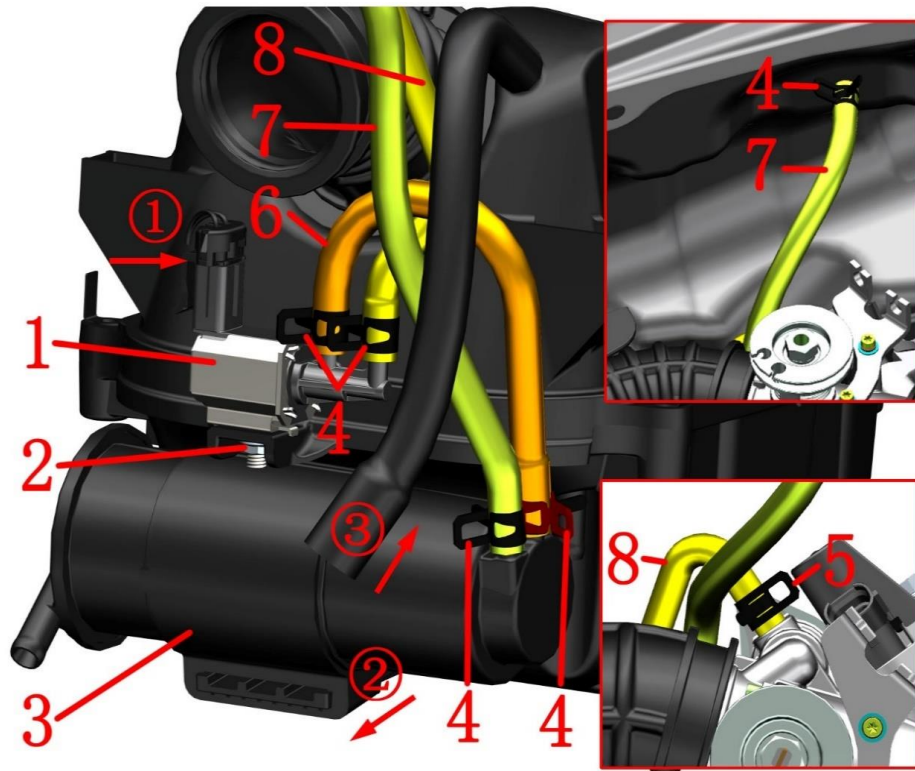

Fig.3 INDUCTION SYSTEM COMPONENT		Induction system component	CHK	⚠
NO.	PART NO.	PART NAME	ADJ	
1	1050954-009000	YH Carbon tank electromagnetic valve	1	CAUTION
2	1250303-040093	GB6177.1M6 (environmental color)(5 pcs/after-sale)	1	
3	1224100-012000	ZT250—S Carbon tank	1	
4	1276001-057000	ZT310 water pipe clamp(φ10.5)(after-sale)	5	
5	1276001-056000	ZT310 water pipe clamp(φ9)(after-sale)	1	
6	1244200-096000	ZT310-V carbon canister solenoid valve intake manifold (Φ5×Φ11/Φ7×Φ13)	1	
7	1244200-095000	ZT310-V carbon Tank adsorption Tube (Φ 5 × Φ 11)	1	
8	1244200-097000	ZT310-V carbon Tank Solenoid Valve exhaust Manifold (Φ 4 × Φ 10 / Φ 5 × Φ 11)	1	

PROCEDURE:

● Carbon tank

Clamp the hoop (4) at the outlet of the oil and gas separator at the bottom of the tank with pliers, unplug the adsorption tube (7), and remove the hoop (shown in the upper right corner). Also remove the outlet pipe (8) and hoop (5) above the throttle valve body assembly (shown in the lower right corner). And the hoop (4) on the left side of the carbon tank (3), remove the adsorption tube (7), and pull out the intake pipe (6) near one end of the carbon tank. Pull the carbon tank down in the direction indicated by arrow ②.

● Carbon tank electromagnetic valve

First remove the connector ① of the carbon tank solenoid valve(1), then remove the nut (2) with the sleeve; remove the solenoid valve assembly. Loosen the hoop (4) and pull out the intake pipe (6) and the outlet pipe (8).

CAUTION:

- It needs to remove the seat cushion, side cover, oil tank cover, bladder and so on.
- Regularly check whether the filter element of the carbon tank and air filter is not ventilated, otherwise it may cause the oil supply to affect the driving experience.
- It should be no crimp, entanglement and other phenomena.

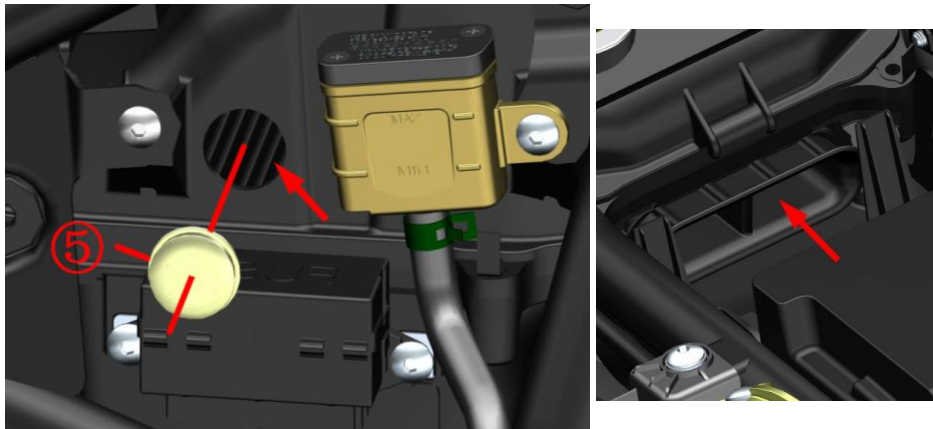
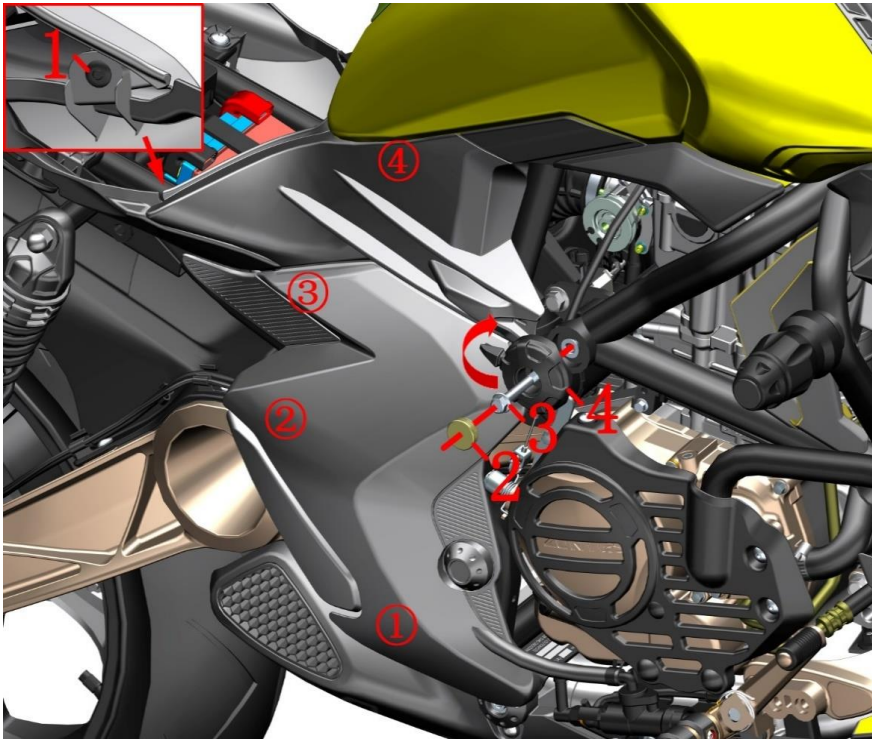



Fig.4 INDUCTION SYSTEM COMPONENT		Maintain the filter element of the air filter	CHK	
NO.	PART NO.	PART NAME	ADJ	
1	1224100-089000	ZT250-S Expansion nail(5 pcs/after-sale)	1	CAUTION
2	1244100-061000	ZT250 anti-water rubber of frame	1	
3	1250105-018091	GB5789 M8×70 (white zinc)	1	
4	4044201-256051	ZT310-v fender ball (dark grey matte)	1	

PROCEDURE:

●Side cover

First remove the cushion, and then remove the expansion nail(1) at the connection between the right cover and the tail skirt. Remove waterproof plug (2) and loosen bolt (3) with T12 sleeve without complete removal. Pull the decorative ball(4) out and rotate clockwise, staggering the grooves on the right cover. Pull out the right cover in the order of①-②-③-④.

●Maintenance

The vehicle should be pushed to a dust-free or dust-free place before the rubber plug⑤ of the air filter is removed, and the filter core should be continuously blown into the air filter with a high-pressure air gun for 10 to 15 minutes, and then the plug should be covered back.

Blow the dirt out of the air inlet with a high pressure air gun, or use a cleaning device to extend the catheter into and absorb the dirt.

CAUTION:

- In the dusty environment, the frequency of cleaning or replacing the filter element needs to be increased.
- Air filter is blocked by dust, which will increase the intake resistance, resulting in insufficient engine intake and fuel consumption or engine damage.
- The filter element or maintenance should be replaced every 10000km under normal conditions. After each rapid maintenance, you can continue to ride or repair the filter after 4000km.

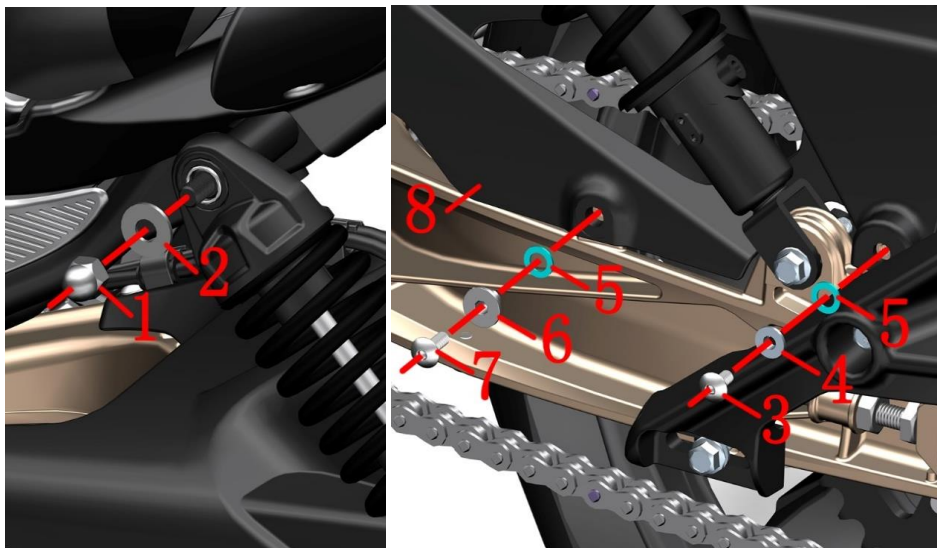

A

B

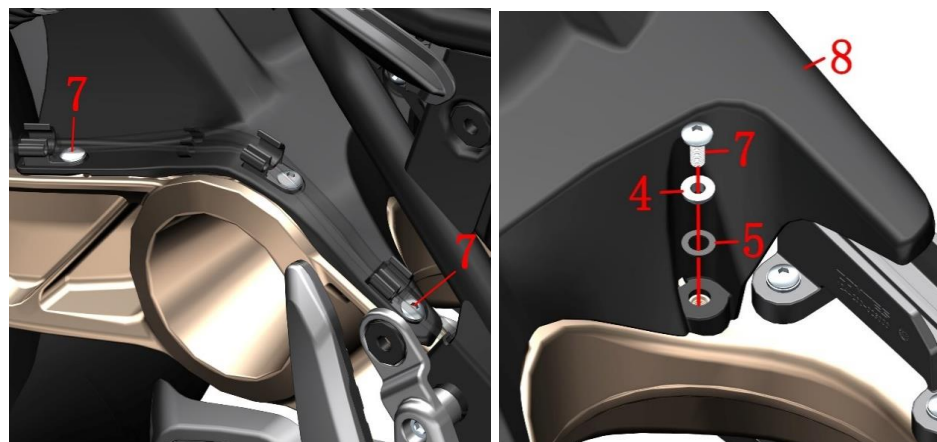

C

D

Fig.5 INDUCTION SYSTEM COMPONENT		Replace the air filter element 1	CHK	CAUTION
			ADJ	
NO.	PART NO.	PART NAME	QTY	
1	1250306-006097	GB923 M10×1.25×18 (Chroming)	1	
2	1251500-007091	Non-standard flat mat φ10.5×φ24×2 (White zinc)	1	
3	1251100-101000	Non-standard bolt M6×12 (304stainless steel)	1	
4	1274100-155095	Flanged bushing φ6.2×φ8.4×3.5+φ14×1.5(5 pcs/after-	2	
5	1241200-124021	flanging bushing buffer rubber (φ8.5×φ14×1)(5 pcs/af	3	
6	1251700-059093	flanging bushingφ6.4×φ9×8+φ18×2 (environmental color)	1	
7	1251100-102000	Non-standard bolt M6×16 (304stainless steel)	3	
8	1224200-110000	ZT310-V rear inner mud plate	1	

PROCEDURE:

- Side cover
Refer to the method of removing the right cover on the previous page, remove the left and right covers.
- Left rear shock absorption
Remove the nut (1) with the sleeve, then remove the flat mat(2).
- Back inner mud board
Remove the bolts (3) and (7) on the left side, remove the bushings (4) and (6), and then remove the cushion rubber (5).
Remove the wheel speed sensor wire and the rear brake caliper tubing from the tubing clamp and remove the two bolts (7) shown.
Remove the bolt (7) on the inside of the front and remove the bushing (4)before removing the cushion rubber (5).
Pull the left rear shock absorbing head outward and remove the rear inner mud plate (8).

CAUTION:

- Do not pull out the stud end face completely when pulling the rear shock absorber head.
- Pay attention to the force when pulling out the wheel speed sensor line and the oil pipe.
- The bolt in the middle of the front right side (Figure C) cannot be removed.

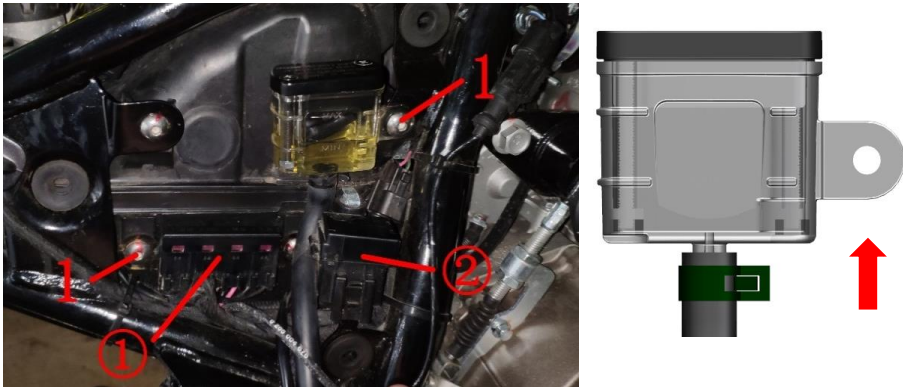
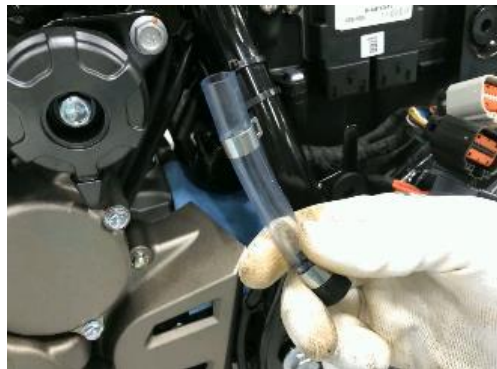
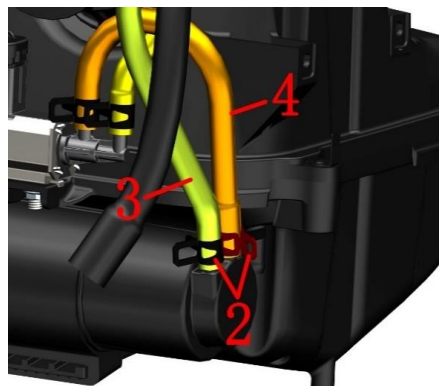
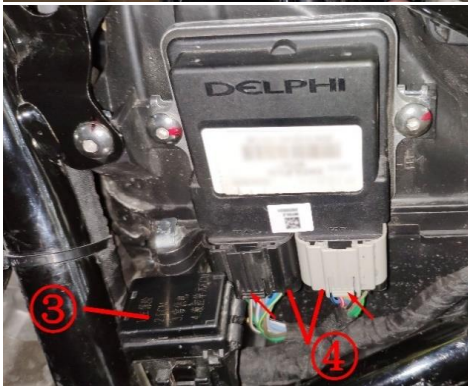

Fig.6 INDUCTION SYSTEM COMPONENT		Replace the air filter element 2	CHK	
			ADJ	
NO.	PART NO.	PART NAME	QTY	CAUTION
1	1251100-102000	Non-standard bolt M6×16 (304stainless steel)	3	
2	1276001-057000	ZT310 water pipe clamp(φ10.5)(after-sale)	2	
3	1244200-095000	ZT310-V carbon Tank adsorption Tube (Φ 5 × Φ 11)	1	
4	1244200-096000	Intake Manifold of Solenoid Valve for ZT310-V carbon Tank (Φ 5 × Φ 11 / Φ 7 × Φ 13)	1	



PROCEDURE:

● Right side

Remove the bolt (1) at the right disc brake oil cup; move the disc brake oil cup to the side and ensure that the oil cup cover is facing up.

Remove the two bolts① of the right fuse box (1) and pull out the fuse box and arrange the cables.

Pull the fuse box② up and arrange the cables.

● Left side

Hold down the arrow at the bottom of the ECU's plug and pull the plug out at the same time and then tidy up the cable.

Pull the fuse box③ up and out the cable.

● Air filter

Clamp the hoop with pliers (2) and remove the boss on the canister. Pull out the suction tube (3) and pull out the intake pipe (4).

Place a rag under the air filter and use a needle-nose pliers to pull out the waste tubing at the bottom.

CAUTION:

● Always keep the disc brake oil cup cover facing up.

● When pulling out the tube, you should not directly clamp it with a nipper pliers to prevent leakage or oil leakage.



A



B



C

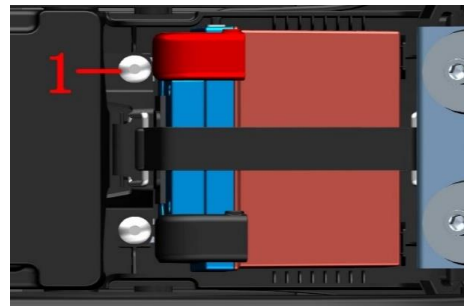

D

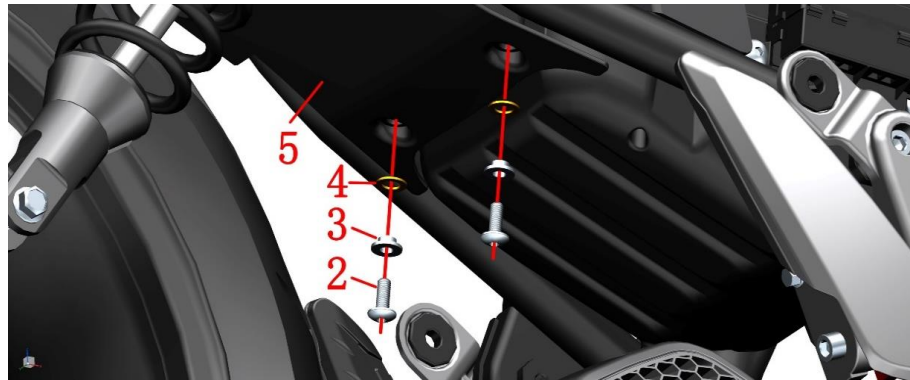

E

Fig.7 INDUCTION SYSTEM COMPONENT		Induction system component	CHK	
NO.	PART NO.	PART NAME	ADJ	
1	1251100-101000	Non-standard bolt M6×12 (304stainless steel)	2	CAUTION
2	1251100-102000	Non-standard bolt M6×16 (304stainless steel)	2	
3	1274100-155095	Flanged bushing φ6.2×φ8.4×3.5 + φ14×1.5(5 pcs/after-	2	
4	1241200-124021	flanging bushing buffer rubber (φ8.5×φ14×1)(5 pcs/af	2	
5	1224200-111000	ZT310-V electrical box	1	

PROCEDURE:

- Air filter
Locate the lock pins at the four corners of the air filter. Open the card and remove the four bolts with a Phillips screwdriver.
- Electric device box
Remove the bolts (1) near the positive and negative terminals of the battery.
Remove the bolt (2) underneath and remove the bushing (3) and cushion rubber (4).
- Air filter bottom case
The front part of the electrical device box (5) is pulled down in one hand, and the air filter bottom case of one hand is taken out.

CAUTION:

- Pay attention to safety when opening the lock card.
- Do not pull it open when pulling down the device box.

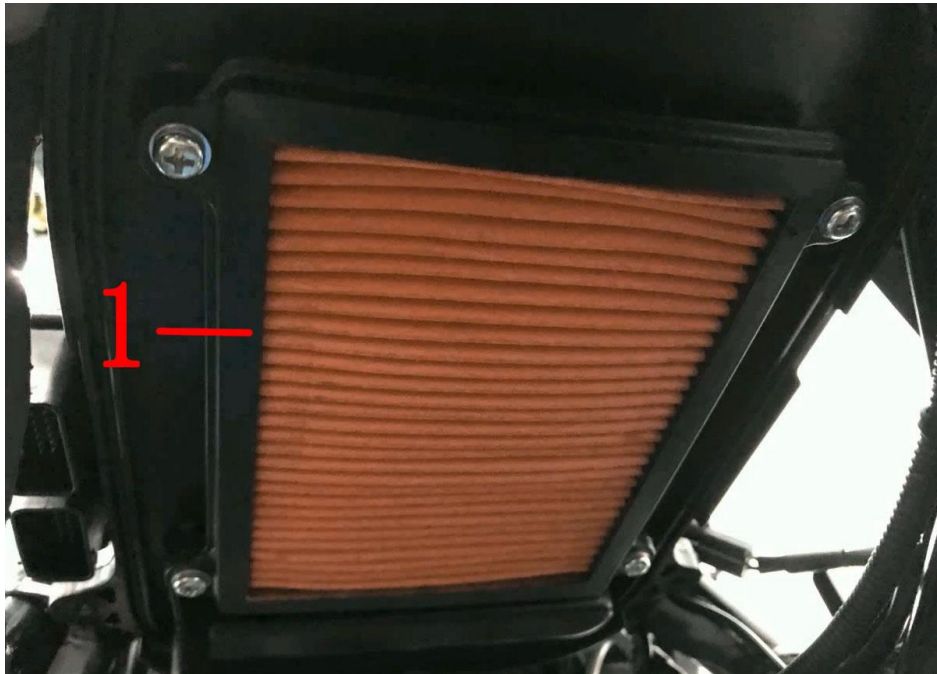

Fig.8 INDUCTION SYSTEM COMPONENT		Induction system component	CHK	
			ADJ	
NO.	PART NO.	PART NAME	QTY	CAUTION
1	1224200-211000	ZT310-V air filter core (with carton packaging)	1	

PROCEDURE:

- Air filter element
Use a Phillips screwdriver to remove the four bolts.
Replace the filter element with a new one.
Prepare new filter elements and seals.
Install the seal into the filter groove and press it tight.
Clean the bottom case.
Reassemble all parts by referring to the removal procedure.



CAUTION:

- The sealing ring must be assembled in place. Leakage or assembly may not cause dust to enter the engine. In severe cases, the internal parts of the engine may be damaged.
- Note that the torque should not be too large when locking the Phillips bolt to prevent damage to the parts.
- When flushing the vehicle, be careful not to allow water to enter the air filter. If a small amount enters, remove the oil pipe and release it. Make sure that there is no water inside the air filter to start the vehicle.

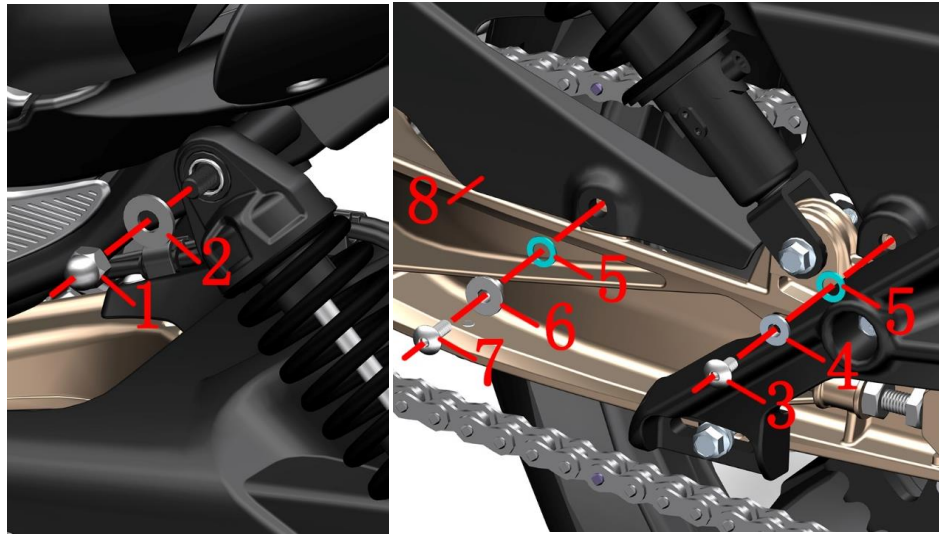

A

B

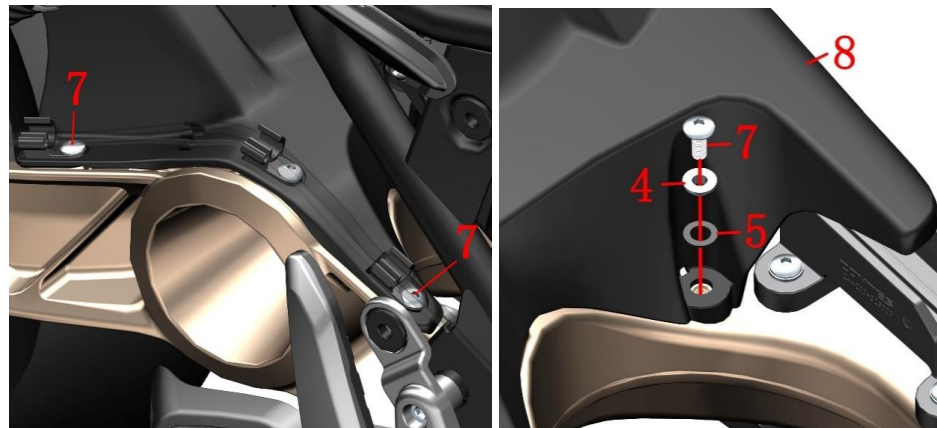

C

D

Fig.9 INDUCTION SYSTEM COMPONENT		Replace the air filter element (Bosch) 1	CHK	
			ADJ	
NO.	PART NO.	PART NAME	QTY	CAUTION
1	1250306-006097	GB923 M10×1.25×18 (Chroming)	1	
2	1251500-007091	Non-standard flat mat φ10.5×φ24×2 (White zinc)	1	
3	1251100-101000	Non-standard bolt M6×12 (304stainless steel)	1	
4	1274100-155095	Flanged bushing φ6.2×φ8.4×3.5+φ14×1.5(5 pcs/after-	2	
5	1241200-124021	flanging bushing buffer rubber (φ8.5×φ14×1)(5 pcs/af	3	
6	1251700-059093	flanging bushingφ6.4×φ9×8+φ18×2 (environmental color)	1	
7	1251100-102000	Non-standard bolt M6×16 (304stainless steel)	3	
8	1224200-110000	ZT310-V rear inner mud plate	1	

PROCEDURE:

● Side cover

Refer to the method of removing the right cover on the previous page, remove the left and right covers.

● Left rear shock absorption

Remove the nut (1) with the sleeve, then remove the flat mat(2).

● Back inner mud board

Remove the bolts (3) and (7) on the left side, remove the bushings (4) and (6), and then remove the cushion rubber (5).

Remove the wheel speed sensor wire and the rear brake caliper tubing from the tubing clamp and remove the two bolts (7) shown.

Remove the bolt (7) on the inside of the front and remove the bushing (4) before removing the cushion rubber (5).

Pull the left rear shock absorbing head outward and remove the rear inner mud plate (8).

CAUTION:

- Do not pull out the stud end face completely when pulling the rear shock absorber head.
- Pay attention to the force when pulling out the wheel speed sensor line and the oil pipe.
- The bolt in the middle of the front right side (Figure C) cannot be removed.

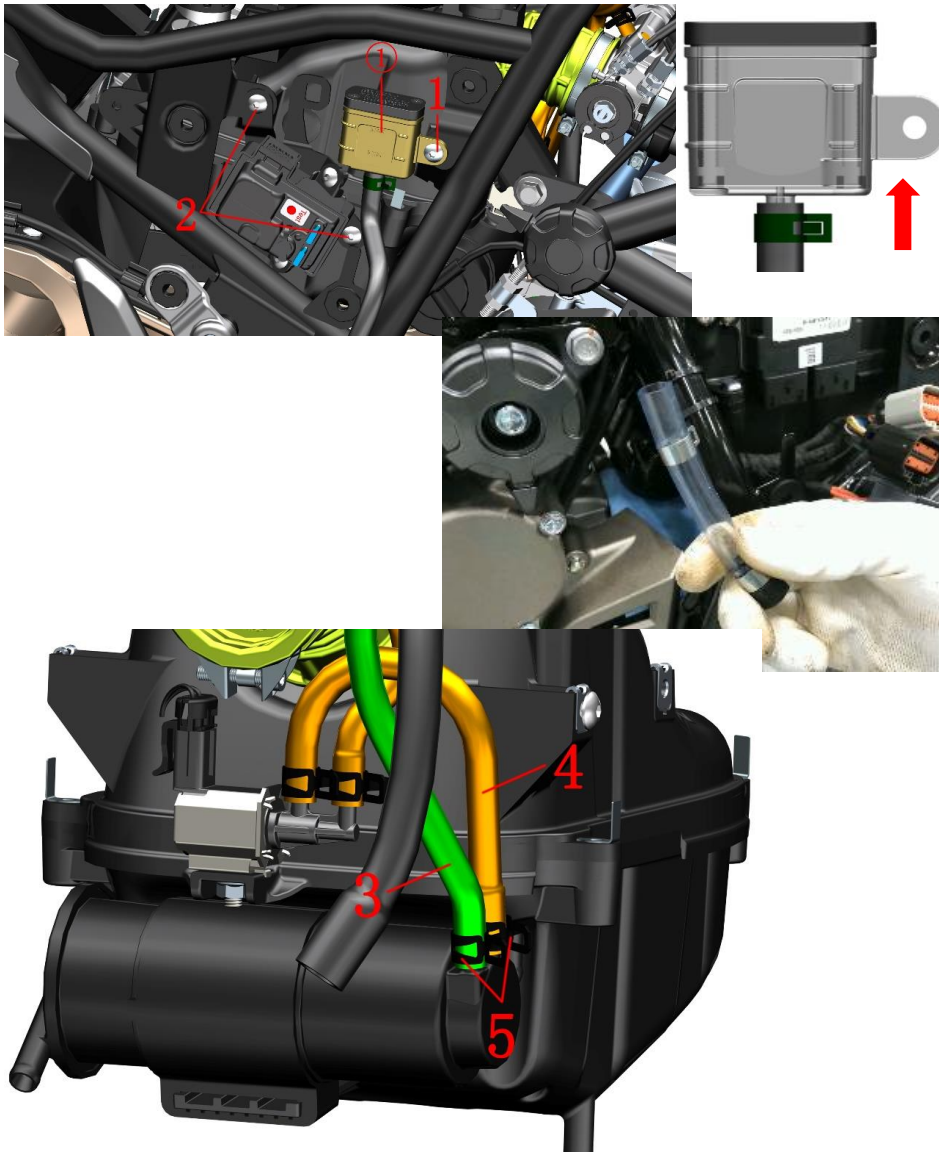



Fig.10 INDUCTION SYSTEM COMPONENT		Replace the air filter element (Bosch) 2	CHK	
			ADJ	
NO.	PART NO.	PART NAME	QTY	CAUTION
1	1251100-102000	Non-standard bolt M6×16 (304stainless steel)	1	
2	1251100-101000	Non-standard bolt M6×12 (304stainless steel)	2	
3	1244200-095000	ZT310-V carbon Tank adsorption Tube (Φ 5 × Φ 11)	1	
4	1244200-096000	Intake Manifold of Solenoid Valve for ZT310-V carbon Tank (Φ 5 × Φ 11 / Φ 7 × Φ 13)	1	
5	1276001-057000	ZT310 water pipe clamp(φ10.5)(after-sale)	2	

PROCEDURE:

● Right side

Remove the bolt (1) at the right disc brake oil cup; move the disc brake oil cup to the side to ensure that the oil cup cover faces upward.

Remove the two bolts (2) of the right PKE mainframe bracket, and arrange the cables.

● Air filter

Clamp the hoop with pliers (5) and remove the boss on the canister. Pull out the suction tube (3) and pull out the intake pipe (4).

Place a rag under the air filter and use a needle-nose pliers to pull out the waste tubing at the bottom.

CAUTION:

● Always keep the disc brake oil cup cover facing up.

● When pulling out the tube, you should not directly clamp it with a nipper pliers to prevent leakage or oil leakage.

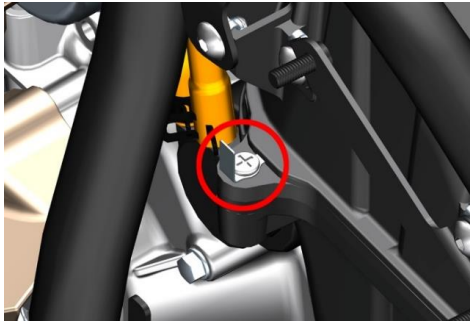

A

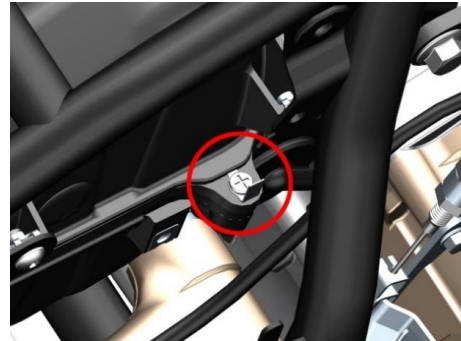

B

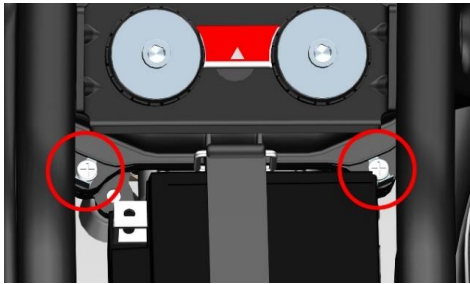

C

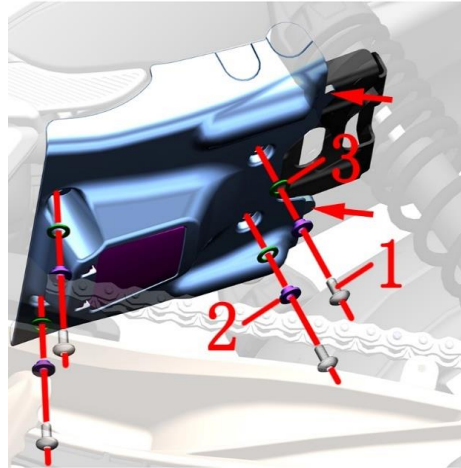

D

Fig.11 INDUCTION SYSTEM COMPONENT		Replace the air filter element (Bosch) 3	CHK	
			ADJ	
NO.	PART NO.	PART NAME	QTY	CAUTION
1	1251100-101000	Non-standard bolt M6×12 (304stainless steel)	4	
2	1274100-155095	Flanged bushing $\phi 6.2 \times \phi 8.4 \times 3.5 + \phi 14 \times 1.5$ (5 pcs/after sale)	4	
3	1241200-124021	flanging bushing buffer rubber ($\phi 8.5 \times \phi 14 \times 1$)(5 pcs/af	4	

PROCEDURE:

● Air filter

Locate the lock pins at the four corners of the air filter. Open the card and remove the four bolts with a Phillips screwdriver.

● Electric device box

Remove the bolt (1) from the bottom, remove the bush (2) and the cushion rubber (3), and remove the battery bottom cover.

● Air filter bottom case

The front part of the battery bottom cover is pulled down in one hand, and the air filter bottom case of one hand is taken out.

CAUTION:

- Pay attention to safety when opening the lock card.
- Do not pull it open when pulling down the device box.

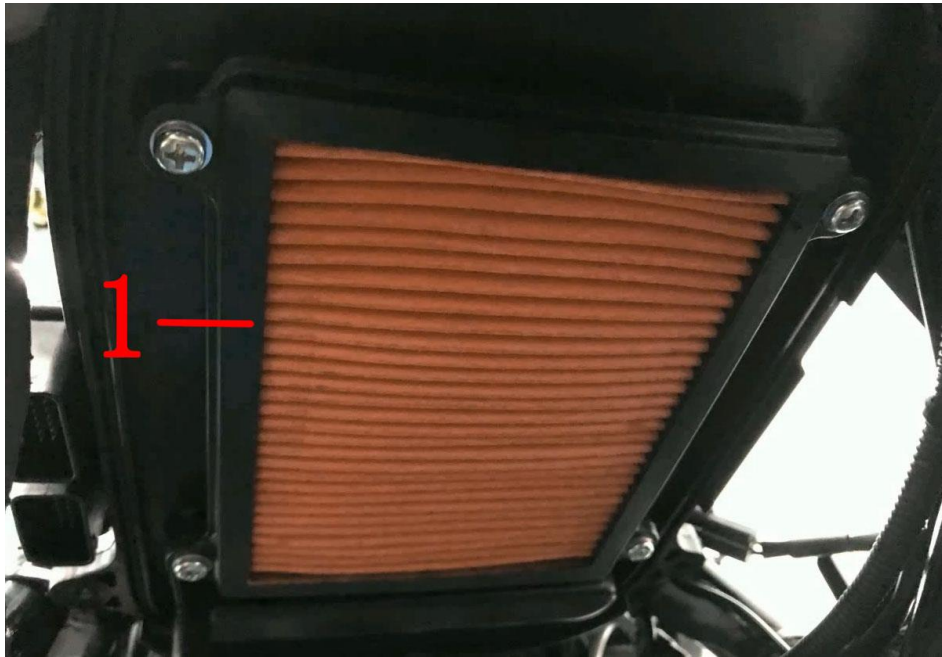

Fig.12 INDUCTION SYSTEM COMPONENT		Replace the air filter element (Bosch) 4	CHK	
			ADJ	
NO.	PART NO.	PART NAME	QTY	CAUTION
1	4134200-001000	ZT310-V air filter core (with carton packaging)	1	

PROCEDURE:

- Air filter element
Use a Phillips screwdriver to remove the four bolts.
Replace the filter element with a new one.
Prepare new filter elements and seals.
Install the seal into the filter groove and press it tight.
Clean the bottom case.
Reassemble all parts by referring to the removal procedure.



CAUTION:

- The sealing ring must be assembled in place. Leakage or assembly may not cause dust to enter the engine. In severe cases, the internal parts of the engine may be damaged.
- Note that the torque should not be too large when locking the Phillips bolt to prevent damage to the parts.
- When flushing the vehicle, be careful not to allow water to enter the air filter. If a small amount enters, remove the oil pipe and release it. Make sure that there is no water inside the air filter to start the vehicle.

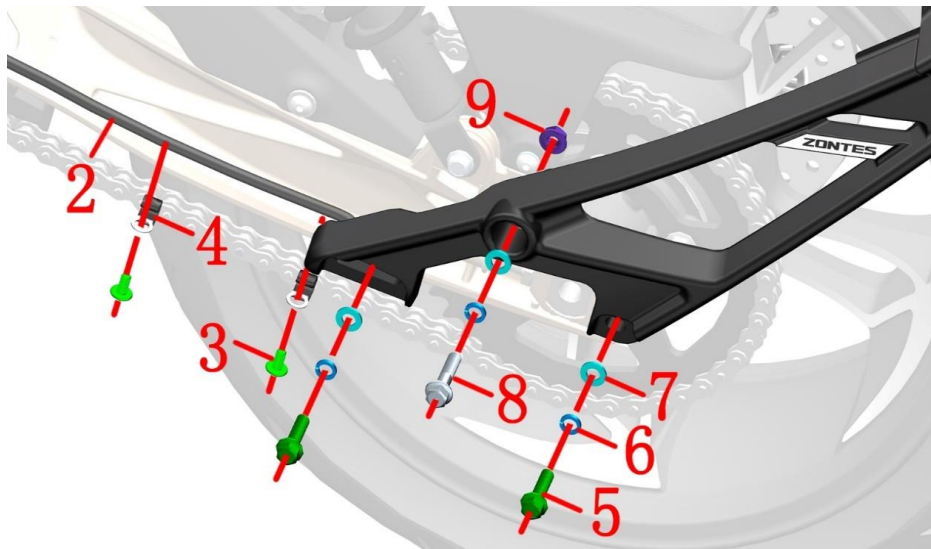
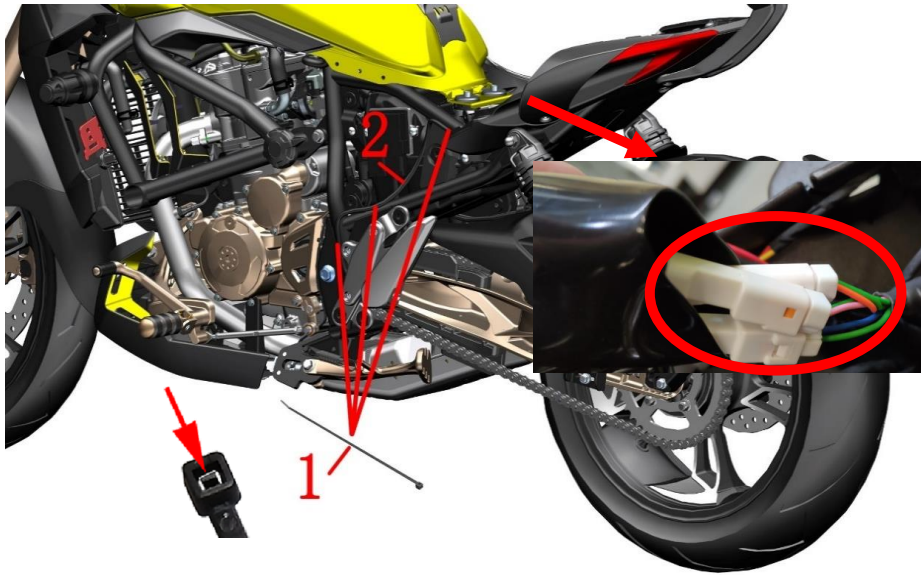

Fig.1 Rear wheel, swinging arm assembly		Rear auxiliary mud plate component 1	CHK	CAUTION
			ADJ	
NO.	PART NO.	PART NAME	QTY	
1	1226000-218000	Grade 0 flame retardant tie (black 3.6×295)(5 pcs/after-	3	
2	1184200-030000	ZT310-R sub-mud board adapter cable (L=2000)	1	
3	1251100-101000	Non-standard bolt M6×12 (304 stainless steel)	2	
4	1274100-095000	ZT250-S Flameout switch wire fixing bracket	2	
5	1250105-143093	GB5789M8×35 (environmental color)	1	
6	1250501-007093	GB93φ8 (environmental color)	3	
7	1250503-021093	GB97.1φ8 (environmental color)	3	
8	1250105-149093	GB5789M8×30 (environmental color)	2	35~40N.m
9	1250303-011093	GB6177.1M8 (environmental color)	1	35~40N.m

PROCEDURE:

●Rear auxiliary mud board assembly

Find the 3 plugs at the transfer plug and unplug the shown three plugs.

Cut or use a tool to pick up the strap (1) head stop.

Remove bolt(3), remove support (4).

After fixing the nut (9) with the plum wrench, then remove the bolt (5) with the sleeve, remove the cushion (6), the flat pad(7) and the nut (9).

After supporting the rear mud plate assembly, remove the bolts (8) with the sleeve, remove the elastic pad (6) and the flat pad (7), respectively.

Remove the auxiliary mud plate transfer line and the rear mud board assembly.

CAUTION:

●The seat cushion, left side cover, etc. must be removed in advance.

●Do not pull the cable hard when removing the sub-mud switch.

●When reassembling, make sure that the torque of the three M8 bolts reaches 35N.m, and you need to apply the thread fastening glue first. Before tightening the bolts, check that there is any pressure on the wires to prevent short circuits when tightening the bolts.

● From 12 November 2019 "a" bolt length changed from 35 to 30.

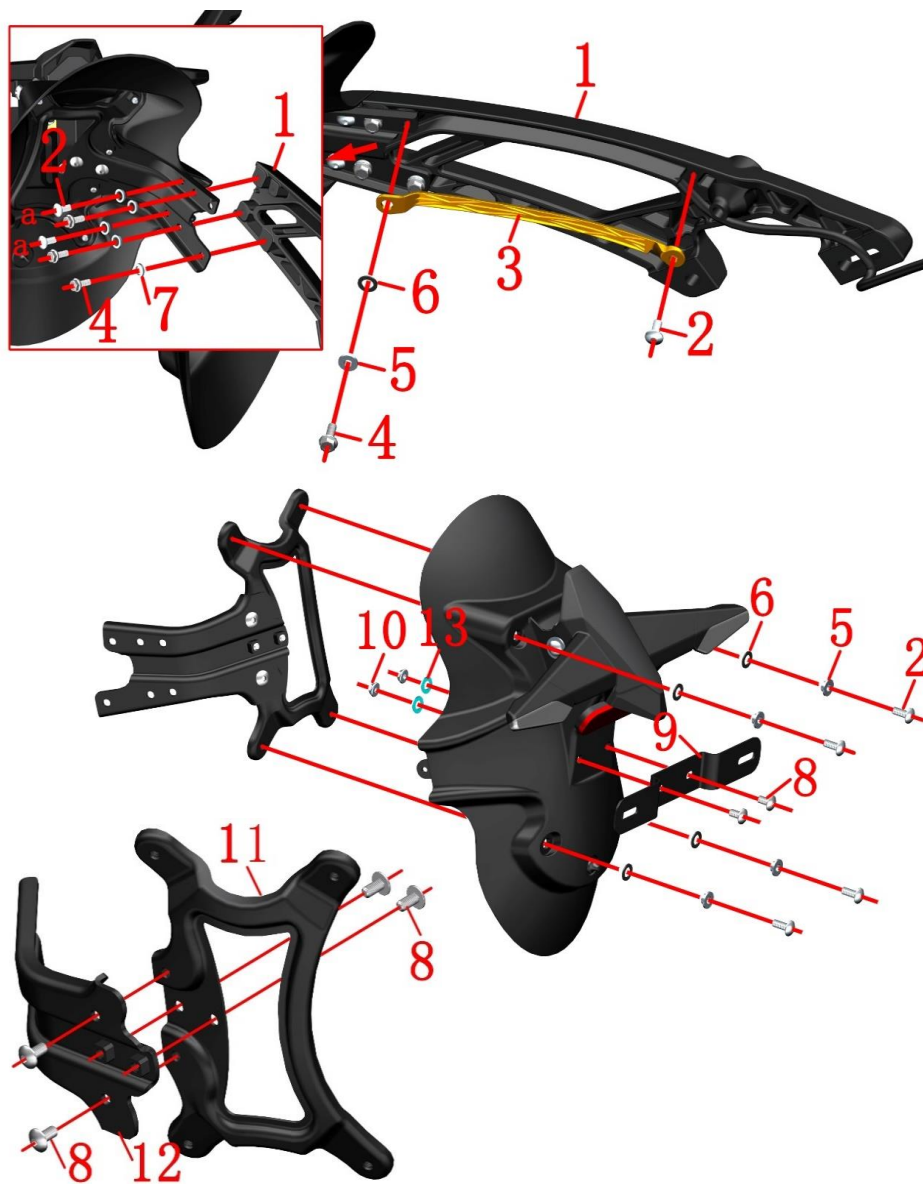

Fig.2 Rear wheel, swinging arm assembly		Rear auxiliary mud plate component 2	CHK	⚠
			ADJ	
NO.	PART NO.	PART NAME	QTY	CAUTION
1	1020242-263021	Rear auxiliary mud plate aluminum alloy bracket	1	
2	1251100-102000	Non-standard bolt M6×16 (304 stainless steel)	7	
3	1224200-090000	Rear auxiliary mud board retaining plate	1	
4	1250105-137093	GB5789M6×16 (environmental color)	4	
5	1274100-155095	Flanged bushing $\phi 6.2 \times \phi 8.4 \times 3.5 + \phi 14 \times 1.5$ (5 pcs/after-	5	
6	1241200-124021	flanging bushing buffer rubber ($\phi 8.5 \times \phi 14 \times 1$) (5 pcs/af	5	
7	1250501-007093	GB93 $\phi 8$ (environmental color)	5	
8	1251100-101000	Non-standard bolt M6×12 (304 stainless steel)	6	
9	1270300-039000	HJ125-6 rear license plate bracket	1	
10	1250303-040093	GB6177.1M6 (environmental color) (5 pcs/after-sale)	2	
11	4024200-036000	Rear section of ZT310-V rear mud plate iron support	1	
12	4024200-035000	Front section of ZT310-V rear mud plate iron support	1	
13	1250503-021093	GB97.1 $\phi 8$ (environmental color)	2	

PROCEDURE:

● Retaining plate

Remove the bolts (2) and (4), remove the flange bushing (5) the rubber pad (6), and finally remove the retaining plate (3).

● Rear auxiliary mud plate iron bracket

Hold the rear turn signal assembly, remove the 2 pcs of bolt (2) and 3 pcs of (4), then remove 5 pcs of spring washer (7). Then take off rear auxiliary mud plate component. Due to the structural optimization "a" should be reduced 2 pcs of bolt (2) and 2 pcs spring washer (7).

Remove the bolt (8) and nut (10) at the license bracket (9) and remove the license bracket (9).

● Iron support

Remove 4 bolts (2), remove flanging bushing (5), rubber pad (6), and finally remove iron support assembly.

Remove 4 bolts (8) to separate the rear section (11) and the front (12) of the iron bracket.

CAUTION:

● Do not pull the cable hard when removing the sub-mud switch.

● When reassembling, first check if there is any pressure on the wire to prevent short circuit when tightening the bolt.

● 2 pcs GB97.1 $\phi 8$ have been added to motorcycle manufactured by July 2021. Early production can add by yourself.

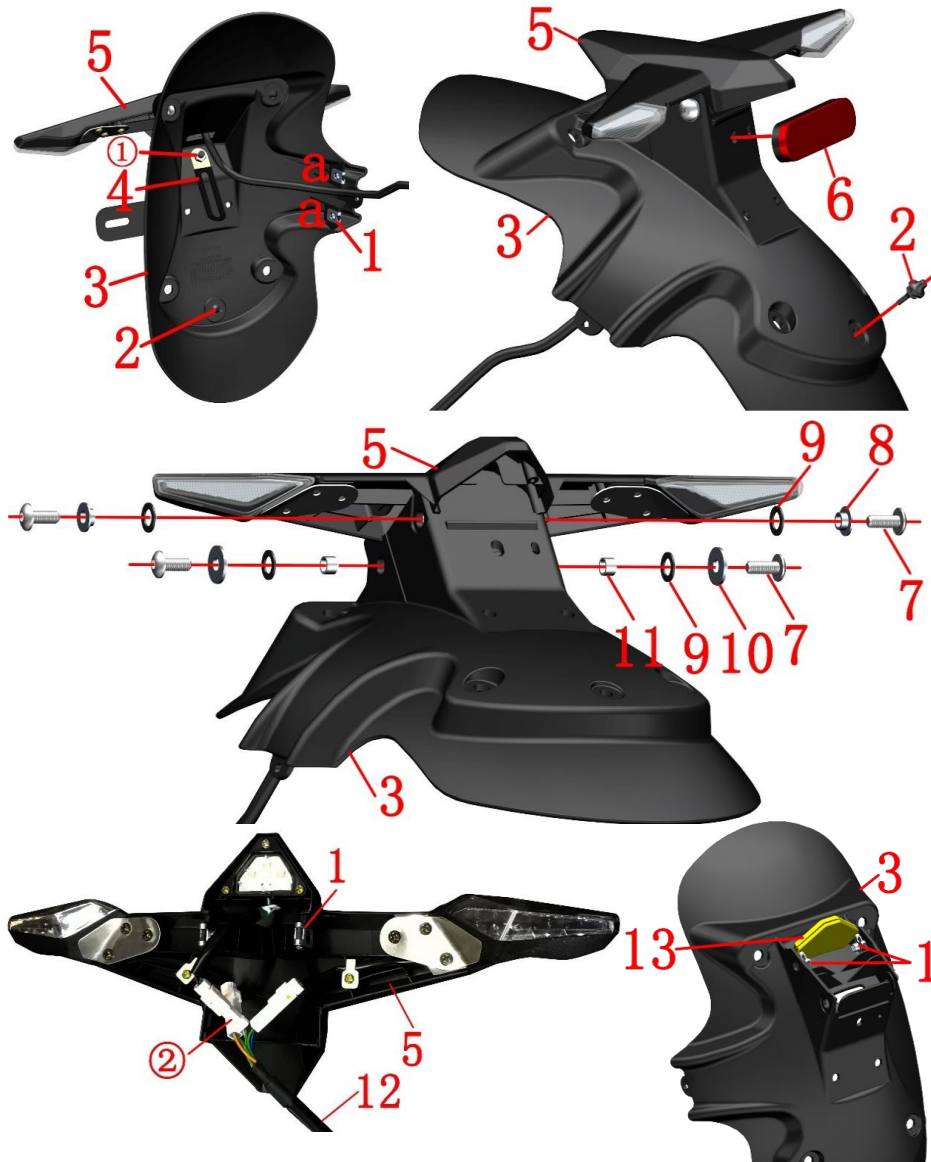

Fig.3 Rear wheel, swinging arm assembly		Rear auxiliary mud plate component 3		CHK	CAUTION
NO.	PART NO.	PART NAME	QTY	ADJ	
1	1251300-063093	Splint M6×11×15 (environmental color)	6		
2	1244100-136000	ZT250-S rear liceness buffer rubber(5 pcs/after-sale)	1		
3	1224200-109000	ZT310-V rear mud plate fende	1		
4	1276001-054000	φ8 clip(L=73)(5 pcs/after-sale)	1		
5	1174200-035000	ZT310 rear turn light (including license plate light)	1		
6	1174100-015000	ZT250-S rear reflector(after-sale)	1		
7	1251100-102000	Non-standard bolt M6×16 (304 stainless steel)	4		
8	1274100-155095	Flanged bushing φ6.2×φ8.4×3.5 + φ14×1.5(5 pcs/after-	6		
9	1241200-124021	flanging bushing buffer rubber (φ8.5×φ14×1)(5 pcs/aft	4		
10	1250502-010093	GB96.1φ6 (environmental color)	2		
11	1274100-018000	ZT250-S muffler anti-scalding bushing	2		
12	1184200-030000	ZT310-R Associate fender transfer cable (L = 2000)	1		
13	1244200-082000	ZT310 Rear auxiliary mud board retaining rubber plug	1		

PROCEDURE:

● Back reflector, license plate cushion rubber

Flip to the back, remove the nut① that comes with the rear reflector (6), remove the clamp (4) and the back reflector. Remove the plate cushion rubber (2) and remove the 2 plywood nuts (1) on the back of the rear mudguard fender (3). Due to the structural optimization "a" should be reduced 2 pcs plywood nuts (1).

● Steering lights, fender sub-assemblies

Remove the bolts (7) on the left and right sides, and remove the flange bushing (8), cushion rubber (9), anti-scalding bushing (11) and gasket (10). Disassemble the turn signal and fender subassembly. Note that the sub-mud switch cable (12) cannot be forcibly pulled.

● fender sub-assembly

Remove the 2 plywood nuts (1) and retaining rubber plug (13) from the fender subassembly (3).

● turn signal subassembly

Remove the 2 plywood nuts (1) from the turn signal (5). Remove the 3 joints of② and remove the sub-mud switch cable (12).

CAUTION:

● Do not pull the cable hard when removing the sub-mud switch.

● When reassembling, check if there is any pressure on the wire to prevent it from tightening. Short circuit caused by bolts. Pay attention to the lamp connector, do not insert the wrong, turn left Green + orange; right turn signal is green + blue; license plate light is green + pink.

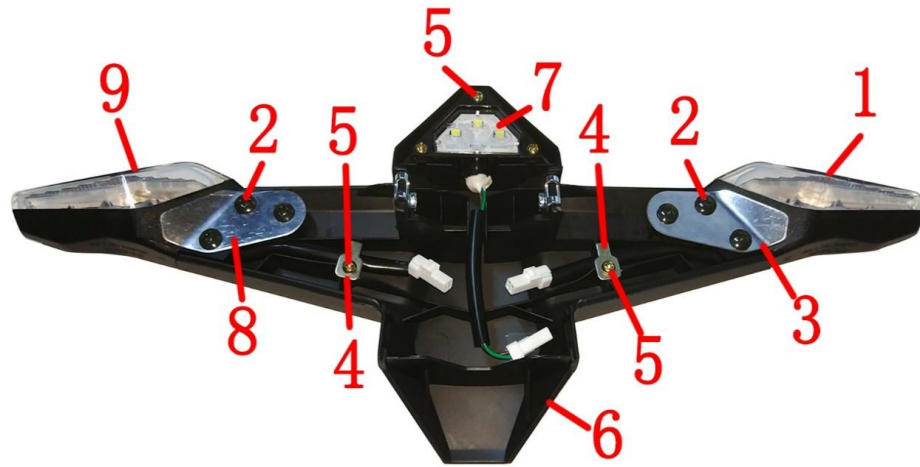

Fig.4 Rear wheel, swinging arm assembly		Rear turning light parts for after sales service		CHK	CAUTION
NO.	PART NO.	PART NAME	QTY	ADJ	
1	1174200-020000	ZT310-X Rear right turning light	1		
2	1251200-056095	Non-standard cross self-tapping screw ST3.8×10 (military green)	6		
3	1274200-331000	ZT310-X rear right turn signal fixing bracket	1		
4	1274200-332000	ZT310 rear turn signal fixing wire clip	2		
5	1251200-101000	Non-standard cross self-tapping screw ST3.0×7 (color zinc)(5 pcs/after-sale)	5		
6	1224200-120000	ZT310 rear turn signal bracket	1		
7	1174200-021000	ZT310-X Liensed lights	1		
8	1274200-330000	ZT310-X rear left turn signal fixing bracket	1		
9	1174200-019000	ZT310-X Rear left turning light	1		

PROCEDURE:

- Rear turning light (license lamp included)

Grip the rear turning light holder (6) then disassemble bolts(5) on the license lamp(7).

Disassemble 3pcs bolts(2) on the diagram left side, and then dismantle left fixing bracket(8) ;disassembly the screw(5) and then reomove the clip(4),take off the left turning light(9).Follow the steps above dismantle right fixing bracket(3), clip(4) and right turning light(1).

CAUTION:

- Avoid fasterning the bolt on the cable while reassembling in case of shrt circuit.

ZT310—X L, rear turning light

ZT310—X R, rear turning light



Fig.5 Rear wheel, swinging arm assembly		Rear inner mudguard	CHK	⚠
NO.	PART NO.	PART NAME	ADJ	
1	1251100-102000	Non-standard Bolt M6×16 (SS)	4	CAUTION
2	1224200-003000	ZT310—Z rear disc brake oil tube cleat	1	
3	1224200-110000	ZT310-V rear mud plate fende	1	
4	1241200-124021	flanging bushing buffer rubber (φ8.5×φ14×1)(5 pcs/af)	3	
5	1274100-155095	Flanged bushing φ6.2×φ8.4×3.5+φ14×1.5(5 pcs/after-	2	
6	1250303-040093	GB6177.1M6 (environmental color)(5 pcs/after-sale)	2	

PROCEDURE:

●Rear inner mudguard

First refer to the steps in the previous "Intake System Assembly-Replace the air filter element 1" to remove the rear inner assembly.

Using the inner hexagon to fix the bolt (1), remove the nut (6), and remove the bush (5) and the buffer adhesive (4). And then the lower bolt (1) and the pipe clamp (2) are taken out.

CAUTION:

●For details of the removal steps of the rear inner mud plate, see "intake system Assembly-replacement of Air filter Core 1".

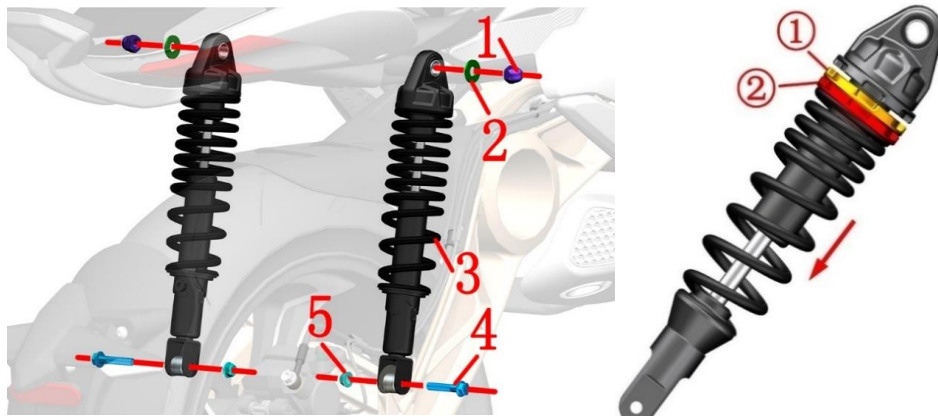

Fig.6 Rear wheel, swinging arm assembly		Rear shock absorber	CHK	⚠
			ADJ	
NO.	PART NO.	PART NAME	QTY	CAUTION
1	1250306-006097	GB923M10 × 1.25x18 (chromium plating)	2	
2	1251500-007091	Non-standard flat padφ10.5×φ24×2 (white zinc)	2	
3	1114200-008006	ZT310-V Rear shock absorber	2	Stop selling NEW
	1114200-018000	ZT310-V Rear shock absorber (improved)		
	1114200-021000	ZT310-V2 Rear shock absorber		
	1114200-034000	ZT310-V rear shock absorber (double barrel)		
4	1250105-150093	GB5789M8×45 (environmental color)	2	
	1250105-143093	GB5789M8×35 (environmental color)		
5	1250305-002091	GB6187.1M8 (white zinc)	2	

PROCEDURE:

●Rear shock absorber

After the motorcycle is supported, one person needs to hold the head of the bolt (4) with a sleeve, and one person uses the sleeve to remove the nut (5). Rotate the bottom of the rear shock absorber (3) backward and rotate the shock absorption on the rear fork to install the hole convex platform.

Remove the nut (1), remove the gasket (2), pull the shock absorber (3) out and remove it.

●Adjust the rear absorber

OLD:Use hook spanner to loosen adjustive nut①. Rotate adjustive nut②. If the nut is rotated towards the arrow direction, the spring becomes harder. Conversely, the absorber is softer. Tighten the adjustive nut① until the absorber is under suitable status. Please adjust in a reasonable range. Riding experience would be influenced either the absorber is too soft or too hard.

NEW:Use a 4# allen wrench to insert the long handle end into the position indicated by arrow ③ in the figure, and directly rotate the shock-absorbing limit slot to adjust the spring preload, a total of five gears.

CAUTION:

- Disassemble seat, L,side cover, R, side cover, bolts on front parts of rear cover and rear inner mudguard.
- Use suitable tool to support the motorcycle. Avoid accidents caused by falling motorcycle. Single person manipulation is prohibited.
- All the standard parts need to reach standard torque while reassembling.
- Due to the adjustment of the spring stiffness; the old spring is φ8~8.2, the new one is φ8.5~8.7, please click the picture to enlarge to see the state. Before August 22, 2019, it was the old one. On August 22, the production was confirmed by the self-control picture; after August 22, it was the new one. If the old shock absorber needs to be replaced, it must be replaced by two rear shock absorbers; if it is new, it can be purchased separately.
- Since April 28, 2020, the rear shock absorber of the ZT310-V model has been changed to the ZT310-V2 rear shock absorber.
- Since march 29,2021,the double barrel rear shock models due to structural changes ,M8 ×45+M8 nut fix instead of M×35 bolt fix ,cancel the thread of shock absorber.

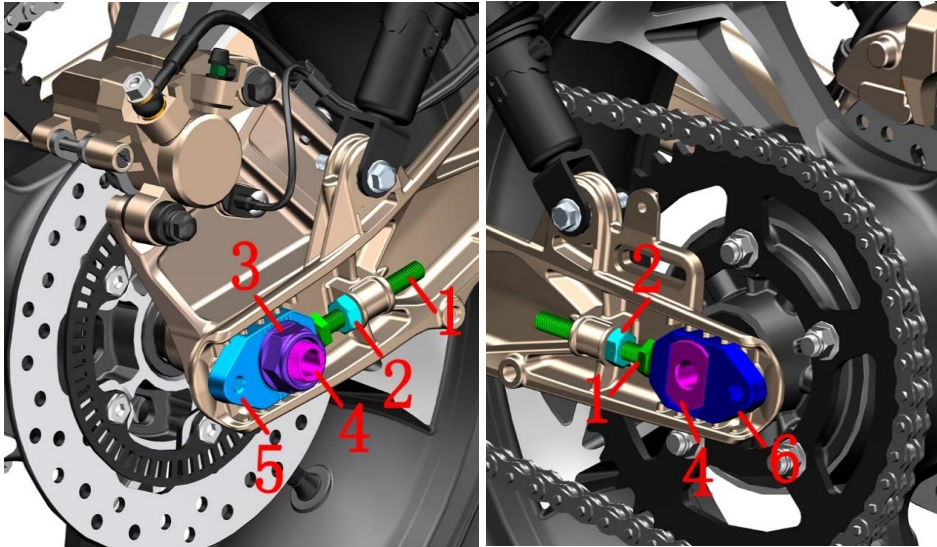

- Wheel axle: Use dial indicator to check if it's deformed or bended.
- The oil seal model $\phi 52 \times \phi 30 \times 7$ of the sprocket seat and the bearing 6205.

Fig.7 Rear wheel, swinging arm assembly		Rear wheel component 1	CHK	CAUTION
NO.	PART NO.	PART NAME	ADJ	
1	1251100-105000	ZT310—Z Chain adjusting bolt M10×70	2	
2	1251300-050000	ZT310—Z Chain adjuster nut M10	2	
3	1032142-073035	ZT310 R, chain adjuster (Titanium)	1	
	1032142-075051	ZT310 R chain regulator (dark gray matte)		
4	1251300-067000	ZT250—R rear wheel axle nut	1	110N.m
5	1032142-072035	ZT310 L, chain adjuster (Titanium)	1	
	1032142-074051	ZT310 L chain regulator (dark gray matte)		
6	1094200-009000	ZT310-V rear wheel hollow shaft	1	
7	1274200-002000	ZT310 Rear wheel right axle sleeve $\phi 20 \times \phi 28 \times \phi 38 \times 18.5$	1	
8	1246500-025000	KD200-C cushion gum	5	
9	1094200-011000	ZT310—R Sprocket bracket	1	
10	1080100-068000	ZT310—T 520—42T sprocket	1	
11	1251300-057093	Non standard nut M10×1.5 (DACROMET)	5	45±3N.m
12	1094100-035000	ZT310 rear wheel left sleeve $\phi 20 \times \phi 30 \times \phi 35 \times 17.8$	1	

PROCEDURE:

● Rear wheel assembly

Disassemble rear wheel axle nut (4) with socket sleeve.

Use open spanner to move chain adjuster nut (2) on both sides towards rear wheel axle until they reach chain adjusting bolt (1). Then rotate the bolt and nut towards motorcycle front direction till the end.

Push rear wheel assembly towards motorcycle front direction and take off the chain from sprocket.

Tie firmly the rear disc brake clamp and avoid it to be lifted higher than disc brake oil cup. Hold the rear wheel assembly. Punch rear wheel axle(6) with rubber hammer. Take off right chain adjuster(3), rear tire and rim assembly, left chain adjuster(5),the rear wheel axle(6).Disassemble the right axle sleeve(7), left axle sleeve(12) at last.

● Sprocket bracket assembly

Put down the rear wheel assemble horizontally. Take off nut (11) with socket sleeve. Take off sprocket(10); sprocket bracket (9). Pull out the sprocket gum cushion (8) from the rim.

CAUTION:

● While disassembling the rear wheel assemble, avoid the rear disc brake clamp to be lifted higher than the disc brake oil cup. If not, air will get into the tubes and cause softness or failure on braking system. As disc brake tubes request extremly high vaccum degree. Make sure manipulator has maintenance ability before disassembling the disc brake assembly.

● Check the chain regularly. Clean the chain every 1500km is suggested. Keep the tightness of chain to be in a suitable range. Too loose chain have possibility to separate from sprocket or damage the engine. Too tight chain can be worn out quickly.

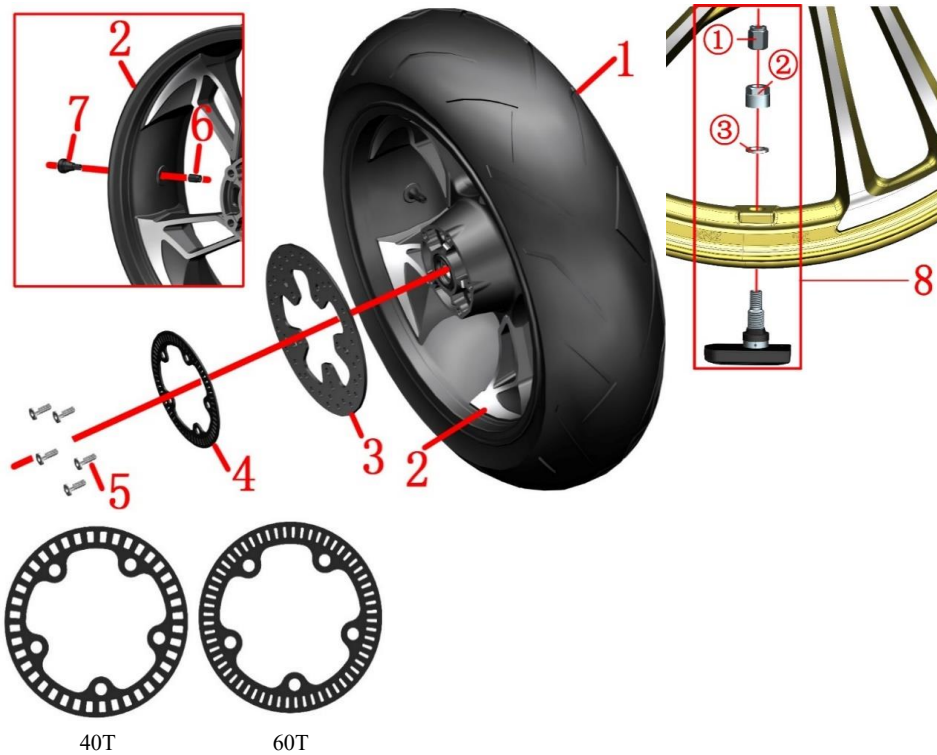

Fig.8 Rear wheel, swinging arm assembly		Rear wheel component 2	CHK	CAUTION
NO.	PART NO.	PART NAME	ADJ	
1	1230100-386000	180/55R17 (CM638) environmentally friendly vacuum rear tire	1	250kPa
2	1094200-022000	ZT310-V rear rim (5.5 × 17)	1	
3	1100100-419000	ZT310-R1 rear disc brake plate (230×4.5)	1	
4	1274200-168021	ABS gear ring(40T)	1	
	1274200-058000	ABS gear ring(60T)	1	
5	1251100-117093	Non standard hex socket bolt M8×25	5	22~24N.m
6	1230200-006000	HJ100-D tire valve cap	1	EURO IV
7	1230100-047000	HJ125-3A environmental tubeless tire valve	1	EURO V
8		Tire pressure sensor	1	

PROCEDURE:

- Disc brake plate, ABS gear ring
Disassemble bolt (5), Then take down the ABS gear ring (4) and the disc brake plate (3).
- EURO IV: Tire and rim assembly
Disassemble tire valve cap (6). Deflate the tire with tools. Then disassemble the rear tire (1) with professional tire changing machine. Disassemble the tire valve (7) with suitable tool.
- EURO V: Tire pressure sensor
Remove the valve cap ① that comes with the tire pressure sensor, use a tool to release the air, and then use a professional tire puller to remove the rear tire (1), taking care to avoid the tire pressure sensor. Finally, use a 12# wrench to remove the valve nut ② and the flat washer ③, and then remove the tire pressure sensor.

● Maintenance

Tire: Check regularly the tire on cracks and air pressure. If the tire is ware to the marker, change the tire with same specification. See details in user manual. Ingradient of tire include semi hot melt rubber. Area with too high temperature is not suitable. If temparature of outdoor is too low, storing the motorcycle in warm place or indoor is suggested in order to avoid frost crack. Normal temperature standard 250kPa.

Rim: Check if the rim has deformation or crack. Support the rim horizontally and check if it can rotate smoothly. Specification of oil seal on rear rim is $\phi 47 \times \phi 28 \times 7$. Bearing type: 6204-2RS.

Disc brake plate: Thickness can not be less than 4mm. If not, change it.

CAUTION:

- Be careful while disassembling the tire and rim in case of damages on the components.
- After changing the tire, check air proof performance and dynamic balance.
- Disqualified tire repair liquid might corrode the rim and cause safety risk.
- Not enough tire pressure can cause abnormal wear and tare. Too high pressure in summer might have possibility of tire bursting.
- It needs running-in for about 300km after changing new rear disc brake plate. During this period, leave enough braking distance while riging.
- The motorcycles produced before May 18, 2019 use 40T inductive gear rings. And then use 60T.

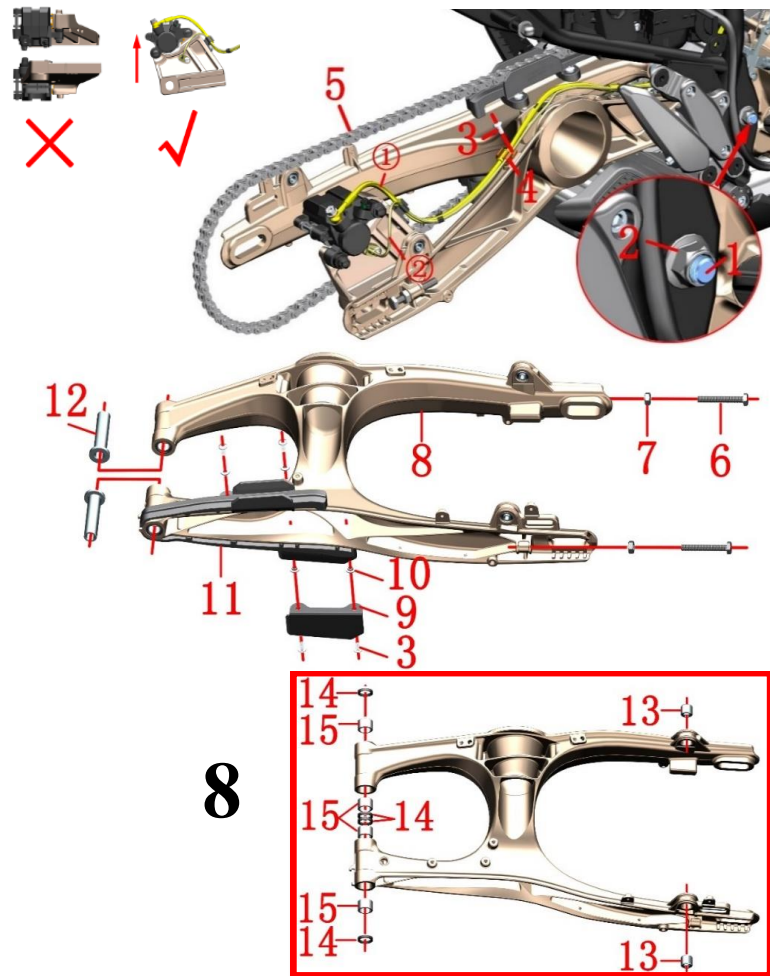

8

CAUTION:

- The rear disc brake caliper must not be higher than the disc brake oil cup, otherwise the brake will become soft or fail due to air entering the pipeline. Because the brake line requires extremely high vacuum, it is necessary to ensure sufficient capacity for repair and disassembly.
- The ZT310-V aluminum alloy rear flat fork assembly (8) including 2 pcs bushing(13), 4 pcs oil seal(14) and bearing(15).

Fig.9 Rear wheel, swinging arm component		Rear swinging arm component		CHK	CAUTION
NO.	PART NO.	PART NAME	QTY	ADJ	
1	1252200-032000	ZT310-V rear flat fork shaft	1		
2	1251300-059093	125Rear fork shaft nutM14×1.5 (Dacro)	1		110±5N.m
3	1251100-102000	Non-standard bolt M6×16 (stainless steel)	5		
4	1224200-003000	ZT310-ZRear disc brake pipe clamp	1		
5	1080200-064000	ZT310-V 118 chain (CHOHO520HX)	1		
6	1251100-105000	ZT310-ZChain adjuster bolt M10×70	2		
7	1251300-050000	ZT310-ZChain adjuster nut M10 (304stainless steel)	2		
8	4024200-049000	ZT310-V aluminum alloy rear flat fork assembly (including bearing/ oil seal)	1		
	4074200-006051	ZT310-V dark gray aluminum alloy rear fork assembly (including bearing/ oil seal)			
9	1274200-116000	Fixed bracket of flat fork anti-wear block after ZT310-V	1		
10	1274100-155095	Flanged bushing φ6.2×φ8.4×3.5+φ14×1.5(5 pcs/after-	2		
11	1244200-026000	ZT310-V rear flat fork anti-wear block	1		
12	1274200-043000	ZT310-V rear flat fork bushing	2		
13	1251700-288000	8×20×19 shock absorption lifting bushing(after-sale)	2		after-sale
14	1104100-005000	ZT250-S oil seal TC20×26×4	4		
15	1094100-001000	ZT250-S needle roller bearing (HK2016)	4		

PROCEDURE:

●Rear fork assembly

Pull off the disc brake oil pipe①and wheel speed sensor② from the disc brake oil pipe clamp (4) ,loosen the bolt(3) and take off the disc brake oil pipe clamp.

The rear disc brake caliper is placed well , always keep the rear brake clamp facing up

One person fastens the head of the rear fork shaft with sleeve, and the other person remove the nut (2) with it.

One person holds the rear fork assembly and the other person removes the rear fork shaft (1) with suitable tool and then remove the rear fork assembly.

●Rear fork rear-resistant block

Remove the bolt (3) ,flanging bushing (10) with respectively inner hexagon tool, remove the anti-wear block support (9) and remove the anti-wear block 11 from the rear flat fork assembly (8).

Remove the chain adjuster bolt (6) and nut (7) with the open end wrench.

Put the rear fork bushing (12) inward and remove it.

Shock absorber hole bushing(13), Oil seal (14) and needle bearing (15) are used for interference compression.

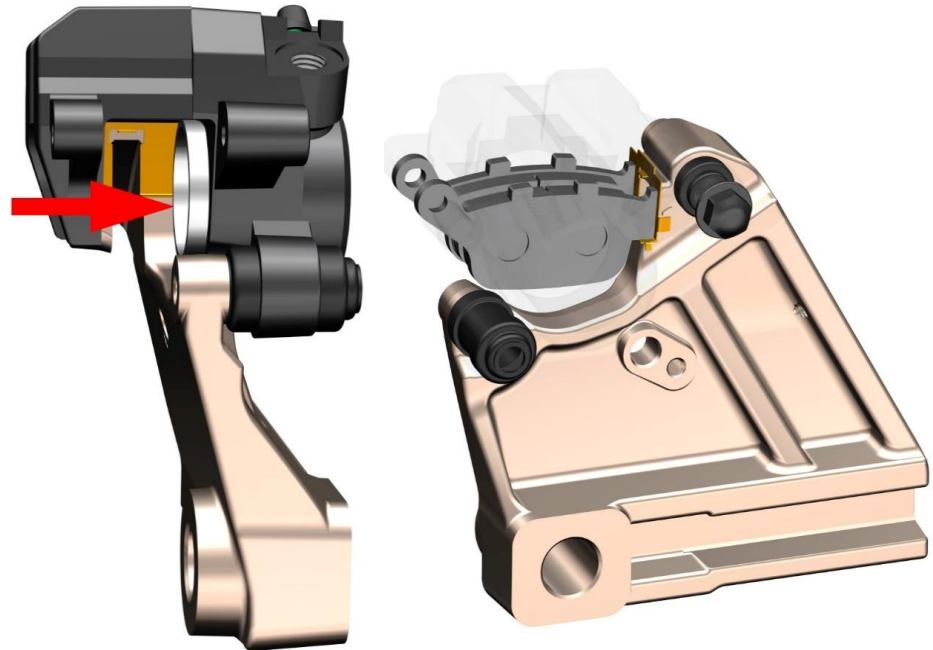
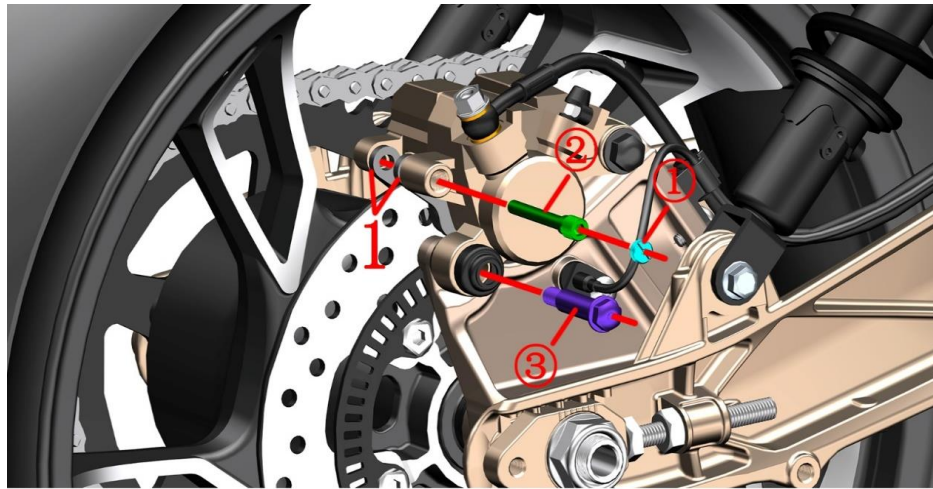

Fig.10 Rear wheel, swinging arm assembly		Change rear brake arresters	CHK	
			ADJ	
NO.	PART NO.	PART NAME	QTY	CAUTION
1	1100100-092000	ZT250—S rear disc brake arrester(HS10)	1	after sale

PROCEDURE:

● Disassemble disc brake arrester

- Use strait screwdriver to disassemble nut①.
- Disassemble pin axle② with hex socket tool.
- Disassemble rolling axle③ with socket sleeve.
- Take off rear disc brake arrester (1).

● Change rear disc brake arrester

Put the piston of clamp towards the direction of arrow to the end. See photo left below. To reduce resistance, you can disassemble the cross bolt on rear disc brake main pump oil cup. Take off the top cover and sealing gasket. Remember to rebound the pister afterwards.

The new arrester must fit tightly the slot. See photo right below.

- Tighten the pin axle② with hex socket tool.
- Tighten rolling axle③ with socket sleeve.
- Tighten nut① with strait screwdriver.

Step on braking pedal several times until braking force is recovered.

CAUTION:

- Check regularly the arrester and disc brake plate status.
- To change arresters in qualified mainenance spot are suggested.
- After changing the arrester, adjust the height of braking pedal according to "Foot pedal, gear shift rod assembly" if necessary.
- It needs running-in for about 300km after changing new arresters. During this period, leave enough braking distance while riging.

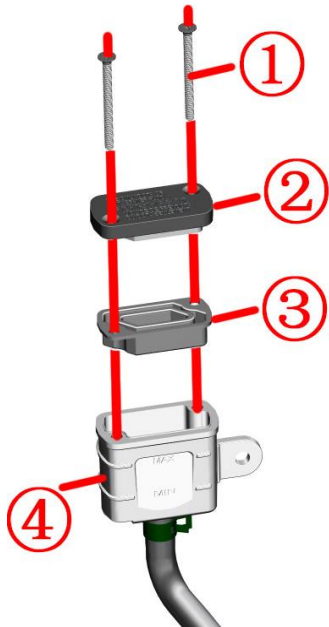
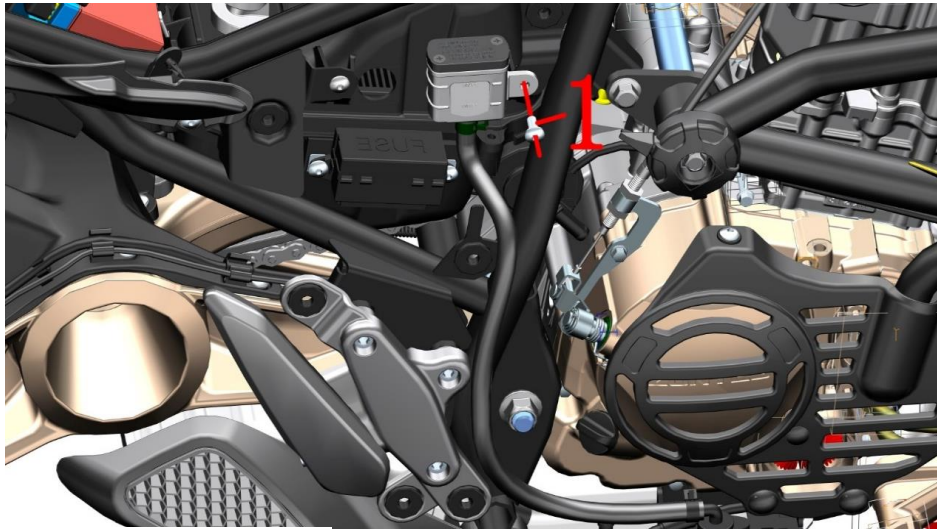

Fig.11 Rear wheel, swinging arm assembly		Rear brake main pump adds brake fluid	CHK	
			ADJ	
NO.	PART NO.	PART NAME	QTY	CAUTION
1	1251100-102000	Non-standard bolt M6 × 16 (stainless steel)	1	

PROCEDURE:

- Add disc brake liquid
 - Remove the cushion and right cover first; remove the bolt(1).
 - Pull out the oil cup and keep the direction up. Avoid braking failure caused by air getting into the oil circulation. Disassemble bolt① with cross screwdriver.
 - Take off oil cup cap②, sealing gasket③.
 - Keep the top of oil cup④ parallel to the ground. Add DOT4 braking liquid. Ensure the liquid level is between "UPPER" and "LOWER".
 - While reassemble, pay attention install sealing gasket③ in correct position and direction.
 - Step gently on the pedal constantly. Do not ride the motorcycle until the braking force is recovered.

CAUTION:

- Support the motorcycle well on flat ground before checking.
- Check regularly if the braking liquid surface is between "UPPER" and "LOWER".
- If liquid surface is below "LOWER", check the arrester status and confirm if the braking system is leaking.
- If the braking liquid is accidentally swallowed, contact intoxication center or hospital immediately. If it gets into the eye, wash it away with clean water then see the doctor.
- Keep the braking liquid far away from children and pets.
- Flush the oil cup directly with high pressure water is prohibited.
- Mixing water, dust, impurity and liquid of silicic acid or petrol series into the braking liquid is prohibited. Otherwise, the braking system would be damaged.

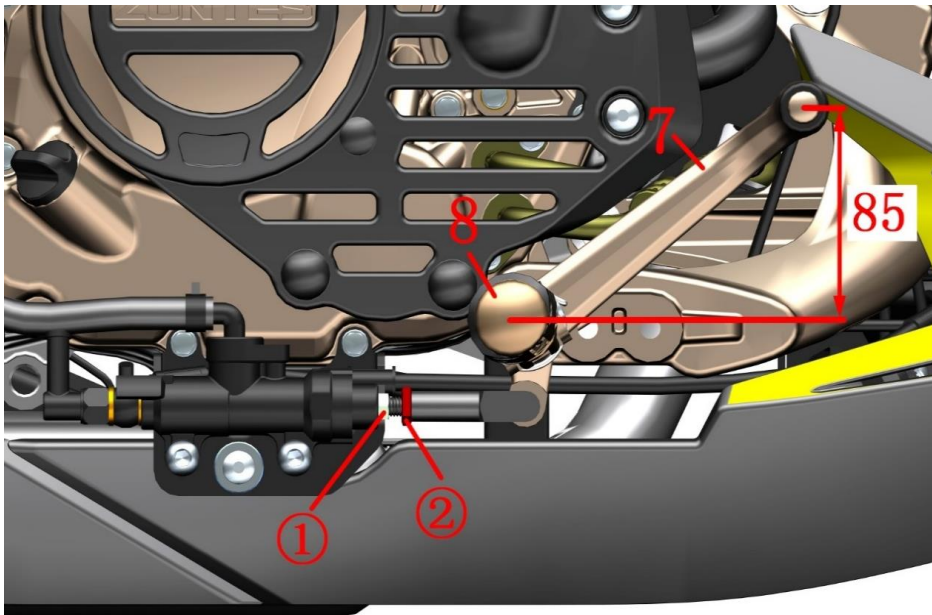
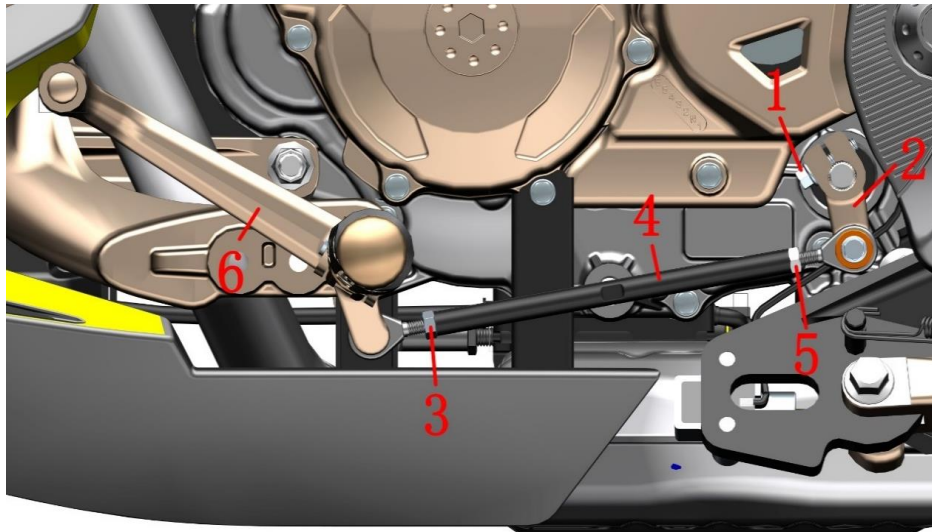

Fig.1 FOOT PEDAL COMPONENT		Adjust the hight of foot pedal	CHK	CAUTION
			ADJ	
NO.	PART NO.	PART NAME	QTY	
1	1251100-061093	M6×22 Hexagon flange bolt 8.8 degree	1	
2	1274100-039000	ZT250—S Gear swift rod spline of Rocker arm	1	
	1271200-163000	ZT250-S gearshift lever spline rocker arm (dark gray)		
3	1250301-049093	GB6170M6 (environmental color)(5 pcs/after-sale)	1	
4	1274100-041000	ZT250—S shift lever adjustment screw	1	
5	1250301-018093	GB6170 M6—LH (environmental color-zinc)	1	
6	1274200-177000	ZT310—V The second generation shift lever step rocke	1	
7	1274200-178000	ZT310—V The second generation brake pedal	1	
8	1274200-224000	ZT310—V Front right pedal assembly	1	
	4064200-006051	ZT310—V Front right pedal assembly (dark gray matte)		

PROCEDURE:

● Adjust the height of gear shift rod

Use an open-end wrench to loosen the nut (3), and nut (5) respectively. Use 8# open spanner to adjust the gear shift rod (4) adjustment bolt until the height becomes suitable. Then tighten the nuts. If the above-mentioned method can not adjust the gear shift rod to a satisfying position, take off bolt (1) and adjust gear shift rod spline of rocker arm (2) with a straight screwdriver by shoving a little bit the groove in the middle while dragging it out. Reassemble after the height is suitable. Pay attention to the aligning of the groove in the middle.

● Adjust the height of brake pedal

Use an open-end wrench to loosen the nut (2). Spin the adjustment rod bolt (1) and adjust the brake pedal (7) to 85mm up to the top pedal (8). Fix the adjustment rod bolt (1) and tighten Nut (2).

CAUTION:

- Ensure the motorcycle is well supported during manipulation. Avoid falling accident.
- The height of gear shift rod should be adjusted to a suitable range. Otherwise the riding experience would be influenced.
- The height of brake pedal should be adjusted to a suitable range. Otherwise the durance of braking shoe and plate would be influenced. In severe case, ineffective braking is possible.

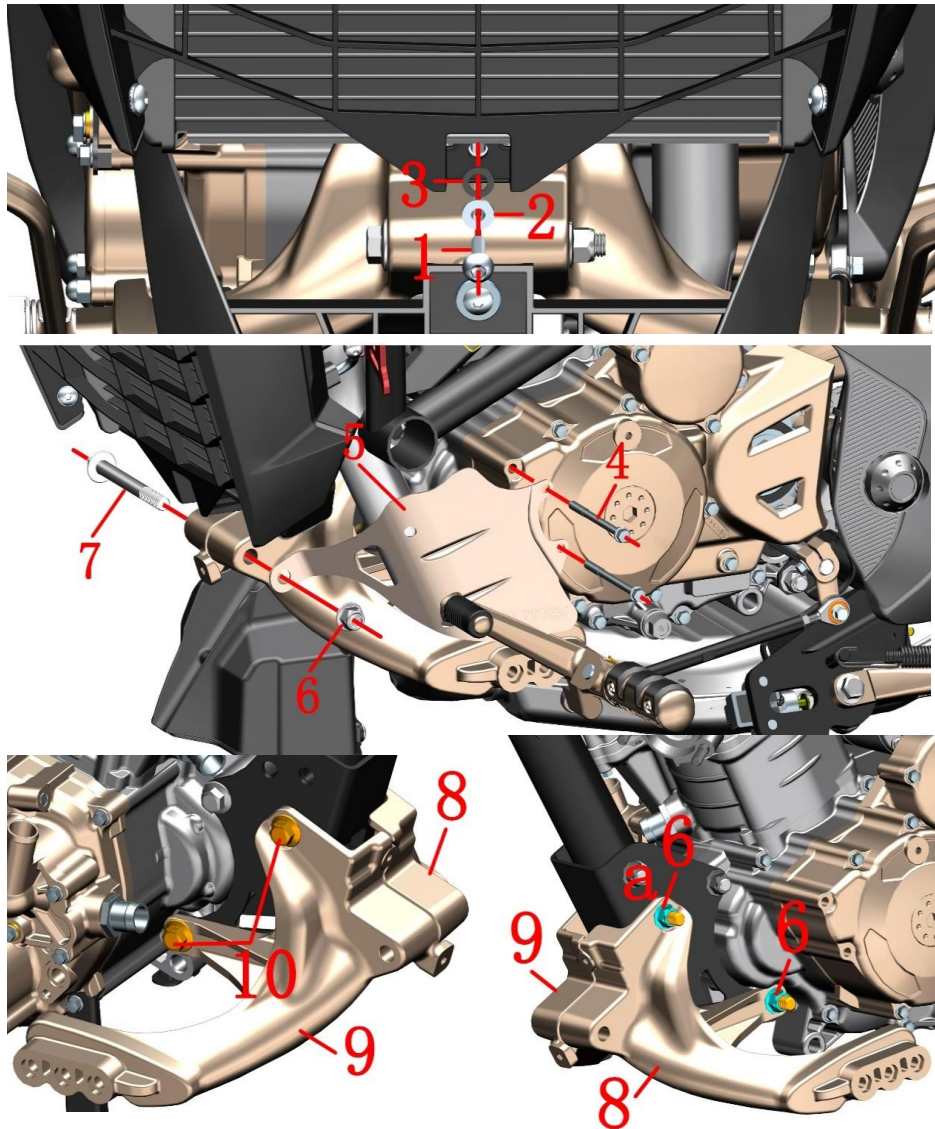

Fig.2 FOOT PEDAL COMPONENT		Front right pedal mounting position adjustment 1	CHK	
NO.	PART NO.	PART NAME	ADJ	
1	1251100-364000	Non-standard bolt M6×25(color/10.9 grade)	1	
2	1274100-155095	Flanged bushing φ6.2×φ8.4×3.5+φ14×1.5(5 pcs/after-	1	
3	1241200-124021	flanging bushing buffer rubber (φ8.5×φ14×1)(5 pcs/af	1	
4	1251112-005093	M6×75 hexagon flange bolt (color zinc)	2	10N.m
5	4024200-058035	ZT310-V Muffler Left Anti-scalding Plate (Titanium)	1	
	4024200-069051	ZT310-V Muffler Left Anti-scalding Plate (dark gray)		
6	1251300-057093	non-standard nuts M10×1.5(Dacromet)	3	65±5N.m
7	1251100-135000	non-standard bolt M10×1.5×95(Dacromet)	1	
8	1274200-092000	ZT310—V front bracket of left footrest	1	
	4064200-001051	ZT310—V front bracket of left footrest (dark gray matte)		
9	1274200-093000	ZT310—V front bracket of right footrest	1	
	4064200-002051	ZT310—V front bracket of right footrest (dark gray matte)		
10	1251100-137000	non-standard boltM10×1.5×100(Dacromet)	2	

PROCEDURE:

●Front pedal bracket

Refer to the step of remove thte shroud component(No need to remove the shroud component) in the "Lower shroud component-Lower shroud component 1".

Remove the the bolts (1) under the radiator cover component,take off the bushing (2) ,buffer rubber (3) .

Grab the anti-scalding plate (5) and remove the 2 bolts (4) to remove it.

Fix the head of the bolt (7) with a sleeve, remove the nut (6), and remove the anti-ironing plate (5).

Secure the nut (6) at the a sleeve with a sleeve and remove the bolt (10) from the left side with the sleeve.

Secure the head of the bottom bolt (10) with a sleeve and remove the nut (6) from the left side with a sleeve. Bolts (7) and (10) are not removed first.

CAUTION:

- Ensure the motorcycle is well supported during manipulation. Avoid falling accident.
- A is required to fix the nut with a Phillips wrench due to the obstruction of the front section of the muffler.
- Early production vehicles do not include a muffler left anti-scalded plate, which can be installed by yourself.

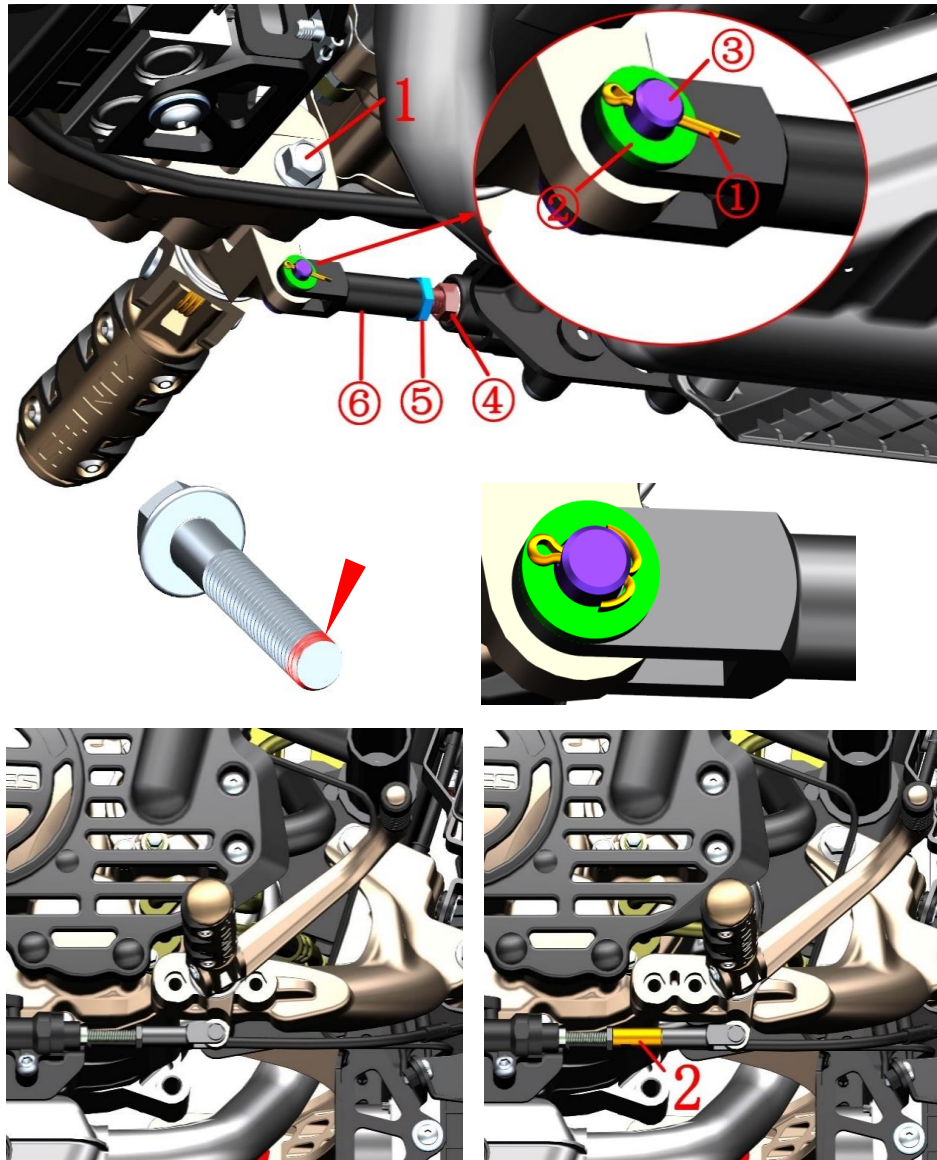

Fig.3 FOOT PEDAL COMPONENT		Front right pedal mounting position adjustment 2	CHK	⚠
			ADJ	
NO.	PART NO.	PART NAME	QTY	CAUTION
1	1250105-150093	GB5789M8×45(environmental color)	1	25N.m
2	1274200-170000	ZT310-V rear brake main pump piston push rod extension rod	1	

PROCEDURE:

- Move forward to one mounting hole for the front right pedal.
Take the cotter pin ① straight and take off it, after taking off the gasket ② and then take off the pin ③.
After pulling out the front right pedal bracket component, use the 12# plum wrench to remove the bolt (1) inside of front right pedal bracket.
Install the front right pedal assembly one hole forward, apply a proper amount of threaded rubber to the threaded head of the bolt (1) and tighten it.
Loosen the lock nut ⑤, adjust the brake pedal to the suitable height and fasten it with one hand, rotates the fork joint ⑥ to the proper position to replace the pin ③, the gasket ② and the split pin ① with the other hand; the cotter pin needs to bend the two legs to both sides.
Confirm the position and lock the nut ⑤. If it is not suitable to adjust the height of the brake pedal on the previous page, rotate the adjusting screw ④ to fine-tune.
- Move forward to two mounting holes for the front right pedal.
It is the same as the step of above, The difference is that an extra length rod (2) is required between the fork joint ⑥ and the lock nut ⑤. This extension is shipped with one standard per vehicle.

CAUTION:

- Ensure the motorcycle is well supported during manipulation. Avoid falling accident.
- The height of brake pedal should be adjusted to a suitable range. Otherwise the duration of braking shoe and plate would be influenced. In severe case, ineffective braking is possible.

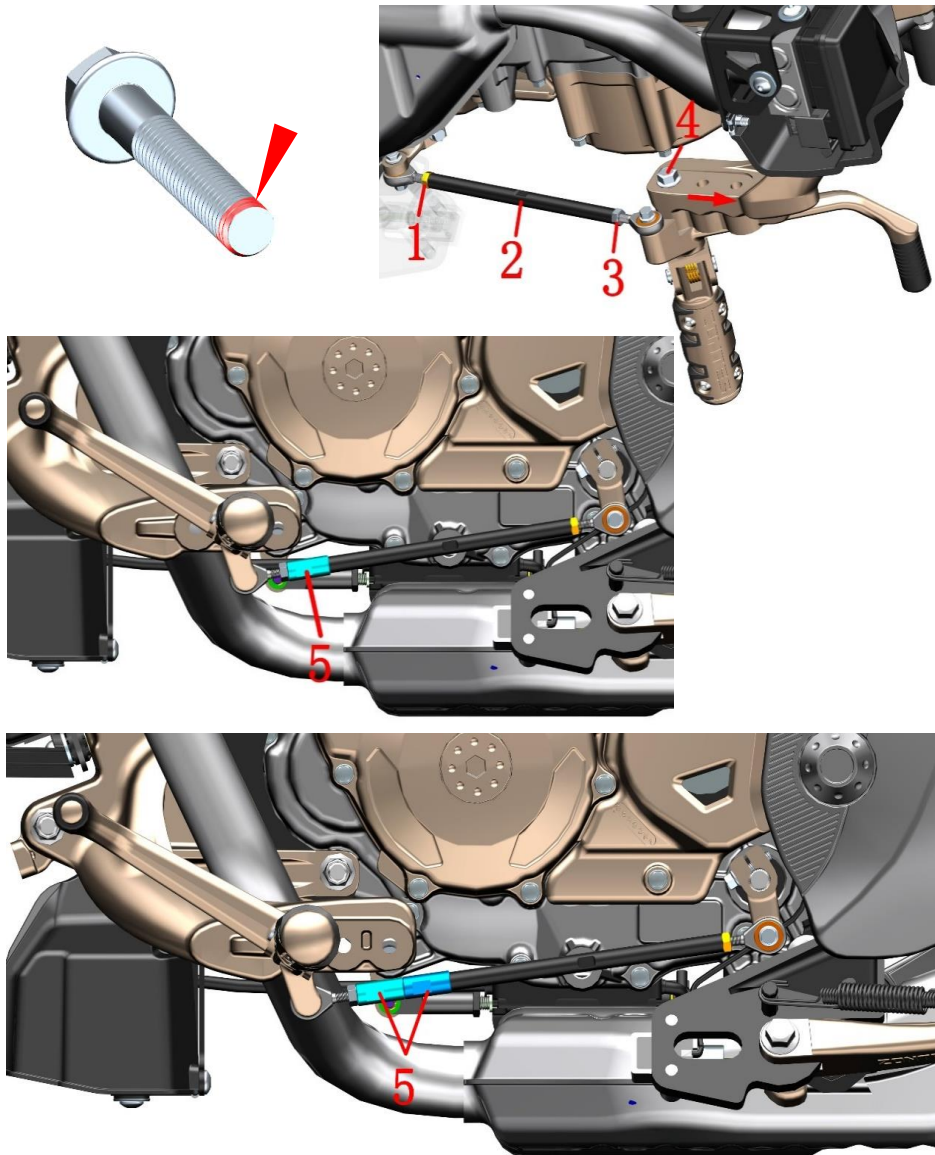

Fig.4 FOOT PEDAL COMPONENT		Front left pedal mounting position adjustment	CHK	⚠
			ADJ	
NO.	PART NO.	PART NAME	QTY	CAUTION
1	1250301-018093	GB6170 M6-LH (army green)	1	
2	1274100-041000	Shift lever adjusting screw	1	
3	1250301-049093	GB6170M6 (environmental color)(5 pcs/after-sale)	1	
4	1250105-150093	GB5789M8×45(environmental color)	1	25N.m
5	1274200-035194	ZT310 front fender bushing (black zinc)	2	

PROCEDURE:

● Move front left pedal forward

First use 8# open-end wrench fasten the groove in the middle of adjustment screw(2), and use the 10# open-end wrench to loosen the nut (1) and (3), and remove the adjustment screw (2).

Remove the bolt (4), move forward to one mounting hole for the front left pedal assembly.

Re-assemble the pedal assembly after applying a proper amount of threaded fastening to the head of the bolt (4).

Use the open-end wrench to install the bushing (5) to the adjustment screw, use 1 piece bushing (5) for 1 hole. The whole car is shipped with two bushings (5) as standard. The bushing can only be fitted to the right-hand thread side of the adjusting screw.

Rotating the adjustment screw and adjustment shift lever to the suitable position and lock the nut (1) and (3).

CAUTION:

- Ensure the motorcycle is well supported during manipulation. Avoid falling accident.
- The height of gear shift rod should be adjusted to a suitable range. Otherwise the riding experience would be influenced.

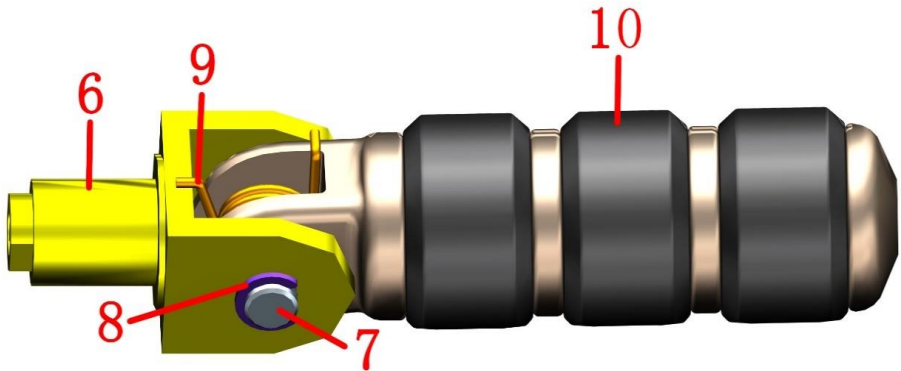
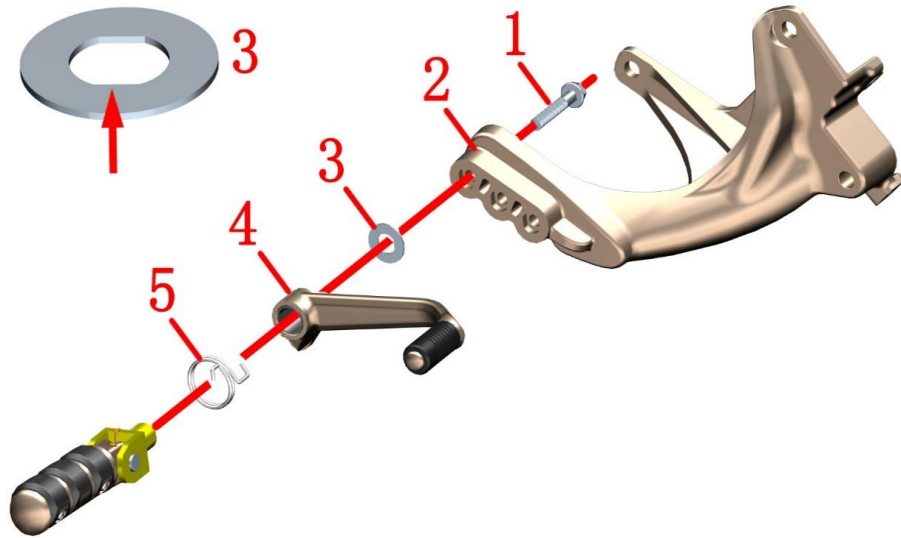

Fig.5 FOOT PEDAL COMPONENT		Front right footrest component	CHK	⚠
			ADJ	
NO.	PART NO.	PART NAME	QTY	CAUTION
1	1250105-150093	GB5789M8×45 (environmental color)	1	25N.m
2	1274200-093000	ZT310-V Front right pedal bracket	1	
3	1251500-048000	ZT250—S Foot pedal holder washer	1	
4	1274200-178000	ZT310-V The second generation brake pedal	1	
	1274200-293000	ZT310-V The second generation brake pedal (dark gray)		
5	1260100-232000	Brake pedal torsion spring(Environmental color zinc)	1	
6	1274100-035000	ZT250—S Foot pedal holder	1	
	1271200-161000	ZT250—S Foot pedal holder (dark gray)		
7	1274100-012000	ZT250—S foot pedal pin axle	1	
8	1264100-006000	ZT250—S foot pedal spring	1	
9	1264100-004000	ZT250—S R, front pedal spring	1	
10	1274200-224000	ZY310-V Front right pedal assembly	1	
	4064200-006051	ZY310-V Front right pedal assembly (dark gray matte)		

PROCEDURE:

●Front right pedal bracket component

Refer to the steps above of removing the pedal bracket component.

Use the seelve to remove the bolt (1) , Take off the bearing gasket (3) ,brake pedal (4) ,brake pedal torsion spring (5) and the order of front right pedal assembly.

●Front right pedal component

Remove the circlip (8),after taking off pin (7), separate the pedal bearing (6), torsion spring (9) and front right pedal assembly (10) .

CAUTION:

- The bearing washer and the boss of the support should be placed and assembled.
- The pedal torsion spring and the brake pedal torsion spring pay attention to the installation direction.

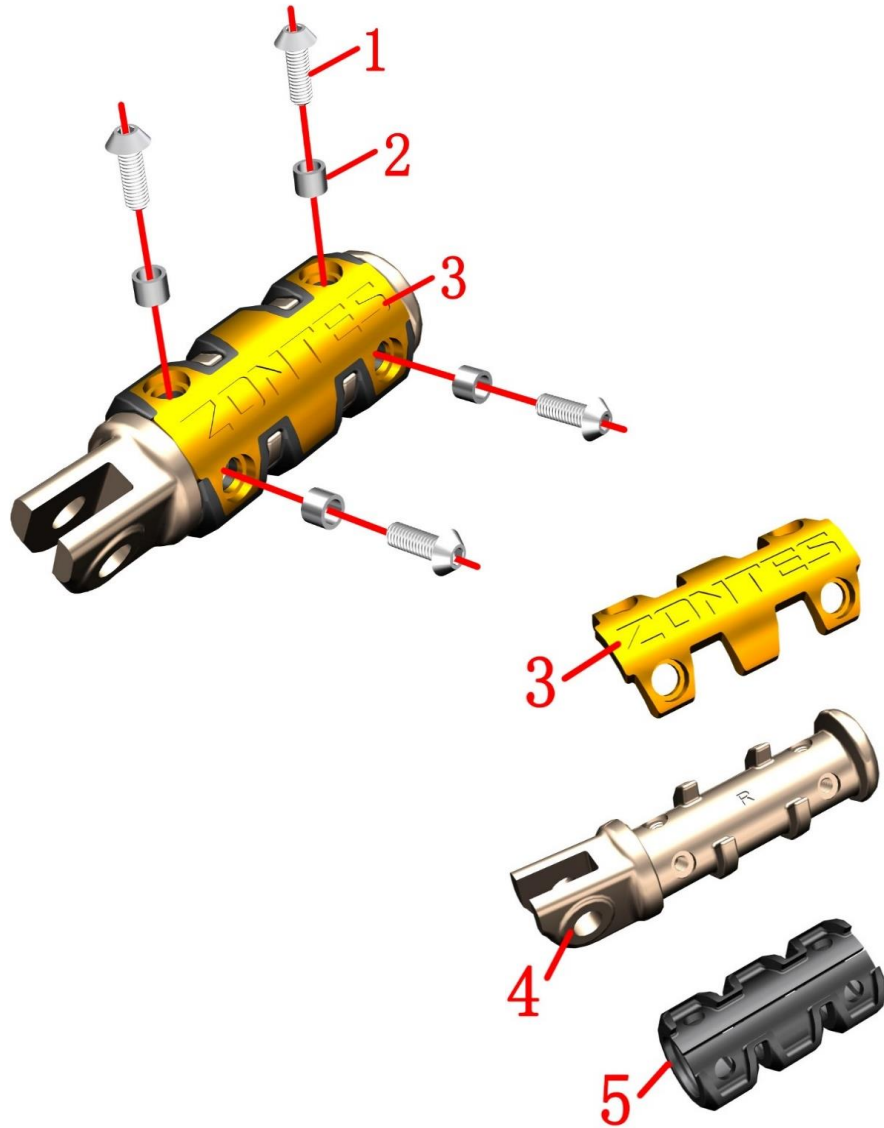

Fig.6 FOOT PEDAL COMPONENT		Front right pedal after sale parts	CHK	⚠
			ADJ	
NO.	PART NO.	PART NAME	QTY	CAUTION
1	1250205-038000	GB70.2M5×12 (Stainless steel)	4	
2	1251700-117000	Bushing Φ7.4×Φ5.4×5.7	4	
3	1032142-051000	ZT310-V Front pedal pressure block	1	
	4064200-003051	ZT310-V Front pedal pressure block (dark gray matte)		
4	1020542-004000	ZT310-V Front right pedal	1	
	1274200-295000	ZT310-V Front right pedal (dark gray)		
5	1244200-063000	ZT310-V Front pedal plastic sleeve	1	

PROCEDURE:

●Front right pedal after sale parts

Remove 4 pieces bolts (1), and take off 4 bushings (2).

Take off the pedal pressure block (3).

Take off the pedal rubber sleeve (5) from the pedal (4).

CAUTION:

●It is recommended to apply a proper amount of thread fastening glue to the head of the bolt (1).

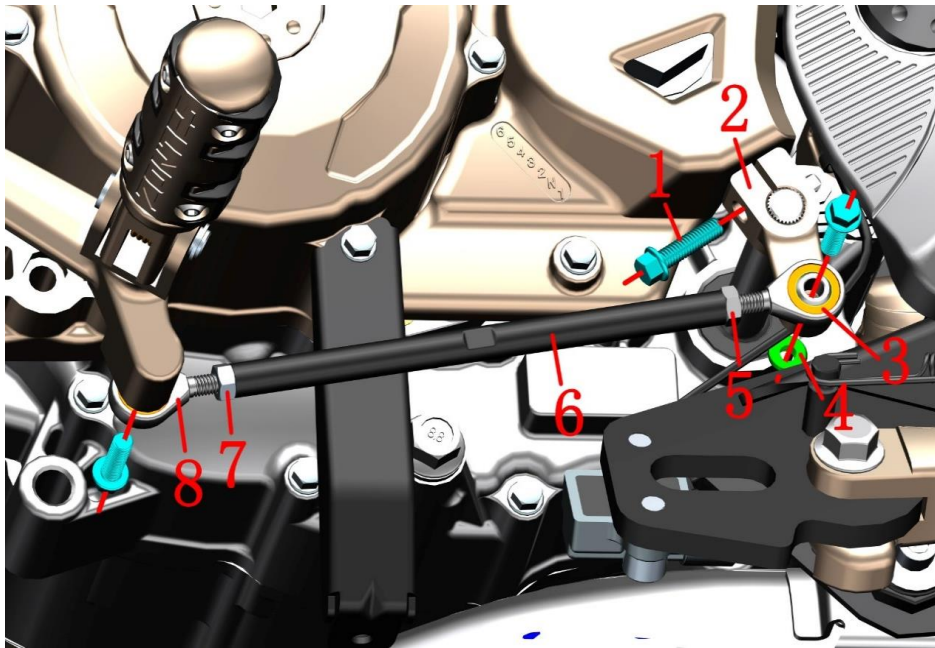

Fig.7 FOOT PEDAL COMPONENT		Shift lever assembly	CHK	
			ADJ	
NO.	PART NO.	PART NAME	QTY	CAUTION
1	1251100-061093	M6×22 Hexagone flange bolt 8.8 degree	3	
2	1274100-039000	ZT250—S Gear shift rod spline rocker arm	1	
3	1274100-043000	Knuckle Bearing SALJK6C	1	
4	1250303-040093	GB6177.1M6 (environmental color)(5 pcs/after-sale)	1	
5	1250301-018093	GB6170M6—LH (environmental color-zinc)	1	
6	1274100-041000	shift lever adjusting screw	1	
7	1250301-049093	GB6170M6 (environmental color)(5 pcs/after-sale)	1	
8	1274100-042000	Knuckle Bearing SAJK6C	1	

PROCEDURE:

● Gear shift rod assembly

Use the 10# open-end wrench to loosen the nut (5) and nut (7), use the 8# open-end wrench to rotate the groove of adjustment screw (6) and take it off. Take off the nut (5) and nut (7). Using the 10# open-end wrench to fix the nut (4) then using the 8# sleeve remove the bolts (1), take off the bearing (3). Using the 8# sleeve remove the bolts (1) at the shift lever step rocker, take off the bearing (8). Using the 8# sleeve remove the bolts (1), then using a flat-blade screwdriver to pull the spline rocker arm (2) in the middle slot slightly and pull it out.

CAUTION:

- Support the motorcycle properly while disassembling in case it falls down.
- Pay attention to distinguishing the nuts at both ends of the knuckle bearing and the adjustment screw.

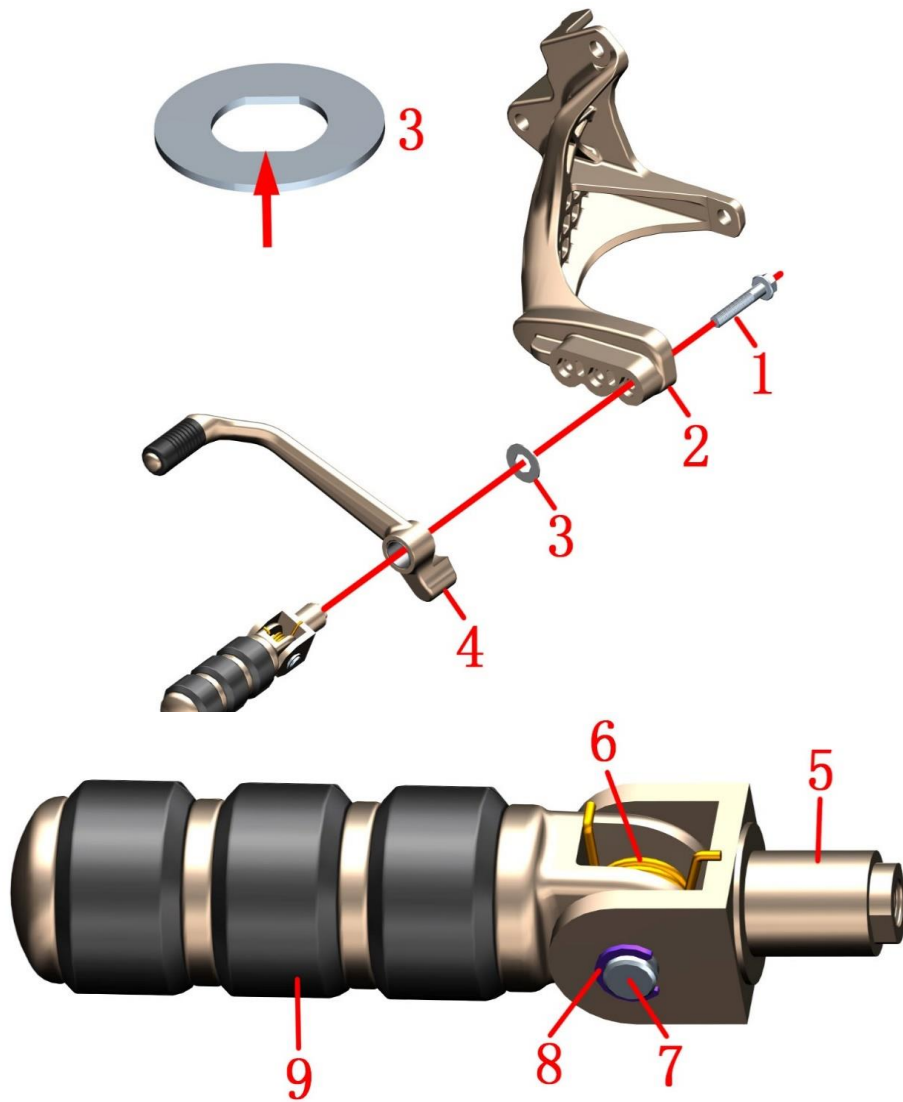

Fig.8 FOOT PEDAL COMPONENT		Front left footrest component	CHK	⚠
			ADJ	
NO.	PART NO.	PART NAME	QTY	CAUTION
1	1250105-150093	GB5789M8×45 (environmental color-zinc)	1	
2	1274200-092000	ZT310—V Front left pedal bracket	1	
3	1251500-048000	ZT250—S Pedal support gasket	1	
4	1274200-177000	ZT310—V The second generation shift lever step rocker	1	
	1274200-292000	ZT310—V The second generation shift lever step rocker (dark gray)		
5	1274100-035000	ZT250—S Foot pedestal	1	
	1271200-161000	ZT250—S Foot pedestal (dark gray)		
6	1264100-003000	front left foot pedal torsional spring	1	
7	1274100-012000	ZT250—S Foot pedal pin axle	1	
8	1264100-006000	ZT250—S Foot pedal circlip	1	
9	1274200-225000	ZT310—V Front left pedal assembly	1	

PROCEDURE:

●Front left pedal bracket component

Refer to to steps above, remove the pedal bracket component.

Use the seelve to remove the blot (1) , take off the bearing gasket (3) ,shift lever (4) and front left pedal assembly by the order.

●Front left pedal component

Remove the circlip (8) and after taking off the pin(7), separate pedal bearing (5) ,torsion spring (6) and front left pedal assembly (9).

CAUTION:

- The bearing washer and the boss of the support should be placed and assembled.
- The pedal torsion spring pays attention to the installation direction.

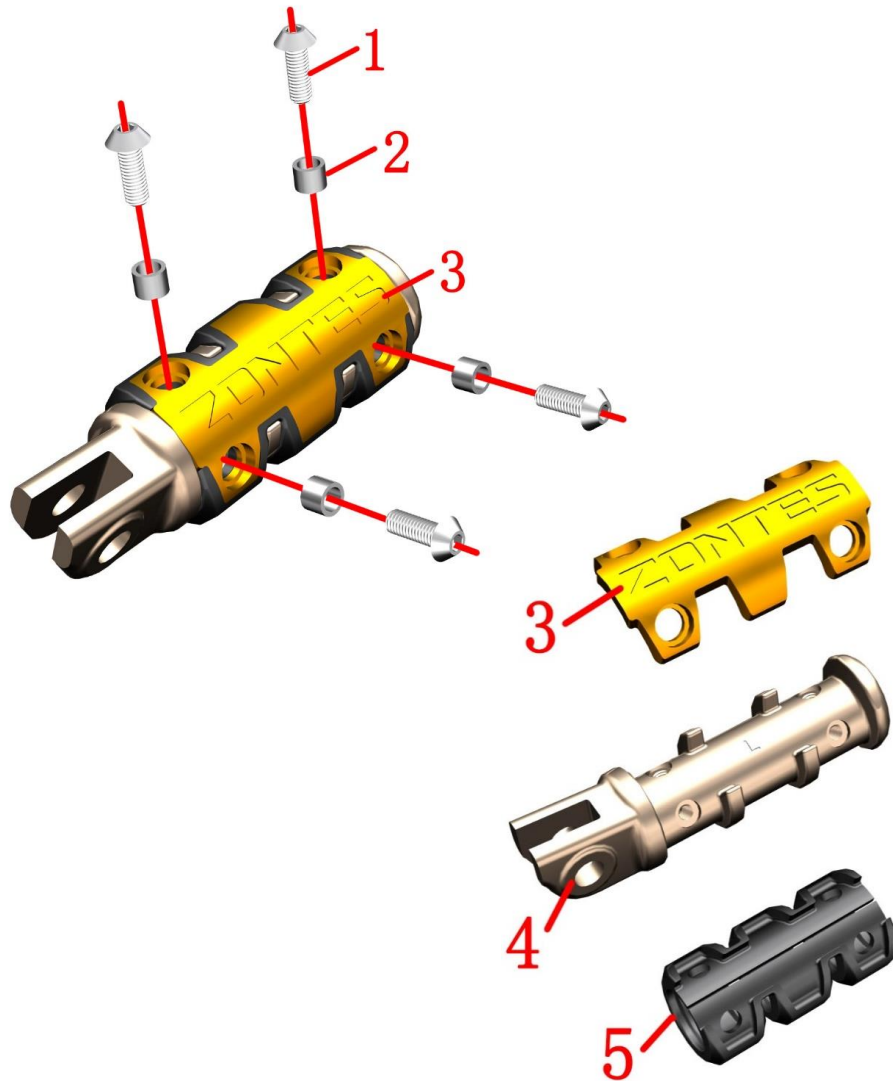

Fig.9 FOOT PEDAL COMPONENT		Front left pedal after sale parts	CHK	⚠
			ADJ	
NO.	PART NO.	PART NAME	QTY	CAUTION
1	1250205-038000	GB70.2M5×12 (Stainless steel)	4	
2	1251700-117000	Bushing Φ7.4×Φ5.4×5.7	4	
3	1032142-051000	ZT310—V Front pedal pressure block	1	
	4064200-003051	ZT310—V Front pedal pressure block (dark gray matte)		
4	1020542-003000	ZT310—V Front left pedal	1	
	1274200-294000	ZT310—V Front left pedal (dark gray)		
5	1244200-063000	ZT310—V Front pedal rubber seelve	1	

PROCEDURE:

- Front left pedal after sale parts.
- Remove 4 pieces bolts (1),and take off 4 bushings (2)
- Take off the pedal pressure block (3)
- Take off the pedal plastic seelve (5) from the pedal (4).

CAUTION:

- It is recommended to apply a proper amount of thread fastening glue to the head of the bolt (1).

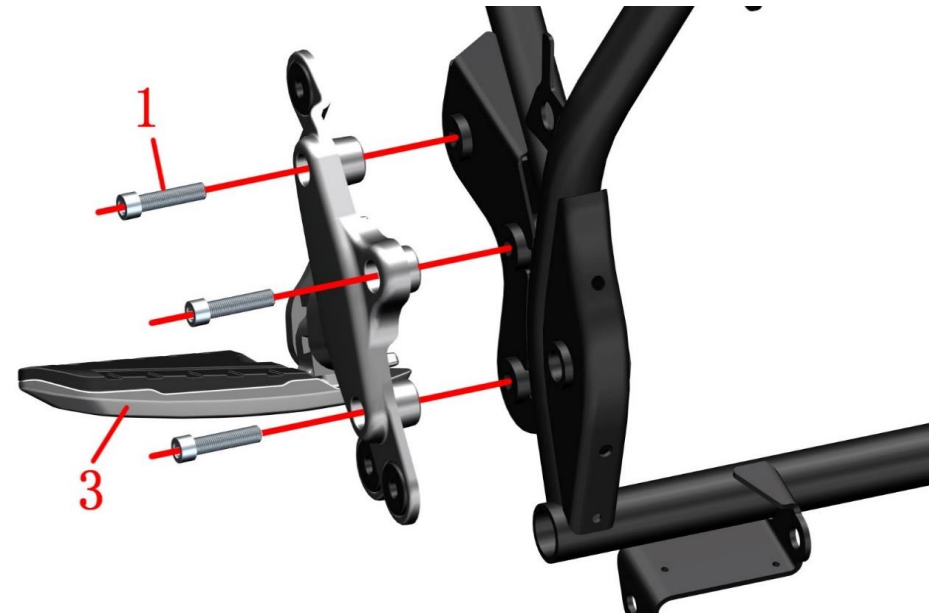
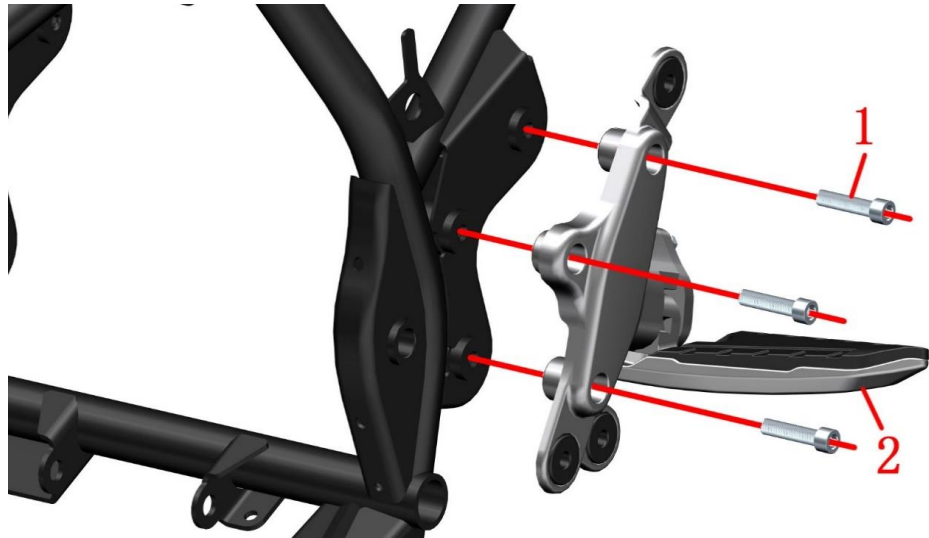

Fig.10 FOOT PEDAL COMPONENT		Rear pedal assembly	CHK	CAUTION
			ADJ	
NO.	PART NO.	PART NAME	QTY	
1	1250205-023000	GB70.1 inner hexagonal M8X35 (army green)	6	
2	1274200-227000	ZT310-V Rear left pedal bracket assembly	1	
	4064200-017051	ZT310-V Rear left pedal bracket assembly (dark gray matte)		
3	1274200-226000	ZT310-V Rear right pedal bracket assembly	1	
	4064200-008051	ZT310-V Rear right pedal bracket assembly (dark gray matte)		

PROCEDURE:

●Rear left pedal bracket assembly

Remove 3 pieces bolts (1) on the left side, take off the left pedal bracket assembly (2)

Remove 3 pieces bolts (1) on the right side , take off the right pedal bracket assembly (3)

CAUTION:

●The rear left and right foot pedal brackets are always equipped with the whole set,including the side cover round glue, pedal bracket, pedal etc.

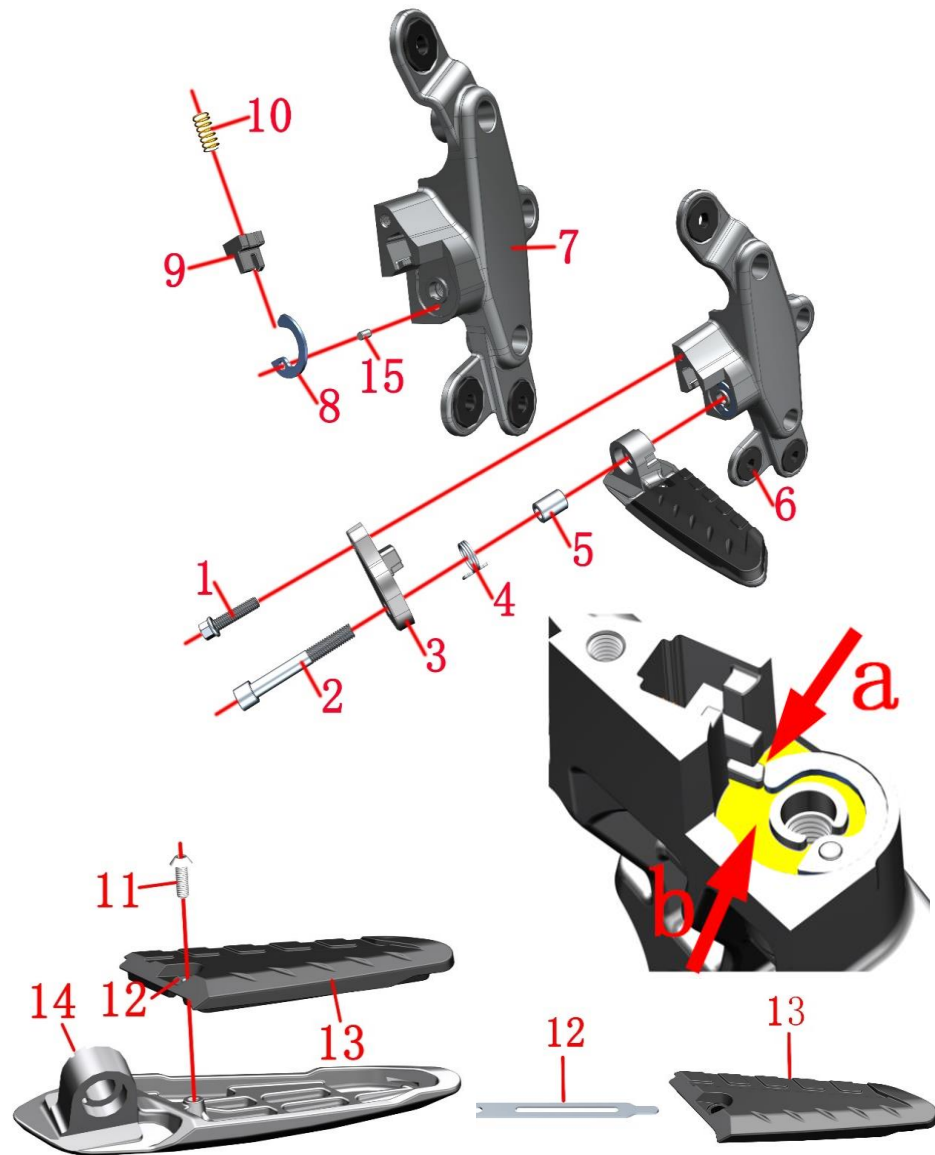

Fig.11 FOOT PEDAL COMPONENT		Rear right pedal bracket components	CHK	CAUTION
			ADJ	
NO.	PART NO.	PART NAME	QTY	
1	1251100-061093	M6×22 Hex flange bolt thread level 8.8 (color zinc)	1	
2	1250205-043093	GB70.1M8×55 (environmental color-zinc)	1	
3	1032142-058000	ZT310-V Rear right pedal cover	1	
	4064200-016051	ZT310-V Rear right pedal cover (dark gray matte)		
4	1260100-353000	ZT310-V rear right foot on torsion spring (extend)	1	
5	1251700-118000	Bushing Φ13×Φ8×18.1	1	
6	1244100-138000	ZT250-S Side cover round rubber(5 pcs/after-sale)	3	
7	1032142-053000	ZT310-V Rear right pedal bracket	1	
	4064200-013051	ZT310-V Rear right pedal bracket (dark gray matte)		
8	1274200-148000	ZT310-V rear pedal top film	1	
9	1032142-050000	ZT310-V Rear right pedal slider	1	
10	1260100-223000	ZT310-V Rear pedal spring	1	
11	1250205-038000	GB70.2M5×12 (stainless steel)	1	
12	1274200-147000	ZT310-V Rear pedal rubber sleeve fixing piece	1	
13	1244200-065000	ZT310-V Rear right pedal rubber seelve	1	
14	1274200-166000	ZT310-V Rear right pedal	1	
	4064200-015051	ZT310-V Rear right pedal (dark gray matte)		
15	1274200-286000	ZT310-V rear footrest top plate hinge pin	1	

PROCEDURE:

●Rear right pedal bracket assembly

Take off 3 pieces side cover round glue (6) from the right pedal bracket(7).

Remove the bolt (1)and (2)take off the cover (3).

Take off the pedal torsion (4) and bushing (5).

Take off the rear pedal component

Take off the pedal top film (8) and footrest top plate hinge pin(15).

Take off the pedal slider (9) and spring (10).

●Rear right pedal

Remove the bolt (11),take off the pedal (14).

The rubber sleeve fixing piece (12) is withdrawn from the pedal rubber sleeve (13).

CAUTION:

●When reassembling, apply a proper amount of grease to the yellow surface indicated by arrow b. Note that the slider top sheet needs to hold the slider.

●From June 16, 2020, when purchasing the ZT310-V rear footrest bracket for the old users, you must also purchase a 1274200-286000 ZT310-V rear footrest top plate hinge pin (15).

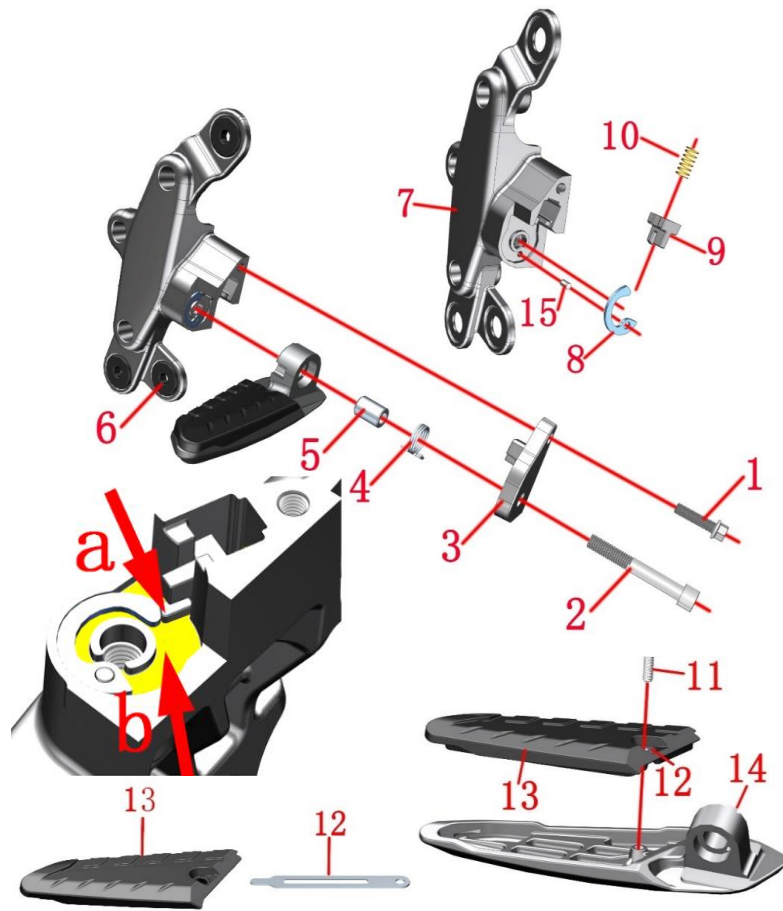

Fig.12 FOOT PEDAL COMPONENT		Rear left pedal bracket components	CHK	CAUTION
			ADJ	
NO.	PART NO.	PART NAME	QTY	
1	1251100-061093	M6×22 Hex flang bolt thread level 8.8 (color zinc)	1	
2	1250205-043093	GB70.1M8×55 (environmental color-zinc)	1	
3	1032142-059000	ZT310—V Rear left pedal cover	1	
	4064200-021051	ZT310—V Rear left pedal cover (dark gray matte)		
4	1260100-352000	ZT310-V rear left foot on torsion spring (extend)	1	
5	1251700-118000	Bushing Φ13×Φ8×18.1	1	
6	1244100-138000	ZT250-S Side cover round rubber(5 pcs/after-sale)	3	
7	1032142-052000	ZT310—V Rear left pedal bracket	1	
	4064200-018051	ZT310—V Rear left pedal bracket (dark gray matte)		
8	1274200-148000	ZT310—V Rear pedal top film	1	
9	1032142-049000	ZT310—V Rear left pedal slider	1	
10	1260100-223000	ZT310—V Rear pedal spring	1	
11	1250205-038000	GB70.2M5×12 (stainless steel)	1	
12	1274200-147000	ZT310—V Rear pedal rubber seelve fixing piece	1	
13	1244200-064000	ZT310—V Rear left pedal rubber seelve	1	
14	1274200-165000	ZT310—V Rear left pedal	1	
	4064200-020051	ZT310—V Rear left pedal (dark gray matte)		
15	1274200-286000	ZT310-V rear footrest top plate hinge pin	1	

PROCEDURE:

●Rear left pedal bracket assembly

Take off 3 pieces side cover round glues (6) from the right pedal bracket (7)

Remove the bolts (1) and (2), and take off the cover (3).

Take off the pedal torsion spring (4) and bushing (5).

Take off the rear pedal component.

Take off the pedal top film (8) and footrest top plate hinge pin(15).

Take off the pedal slider (9)and spring (10).

●Rear left pedal

Remove the bolt (11), and take off the pedal (14).

The rubber sleeve fixing piece (12) is withdrawn from the pedal rubber sleeve (13)

CAUTION:

●When reassembling, apply a proper amount of grease to the yellow surface indicated by arrow b. Note that the slider top sheet needs to be held against the slider as indicated by arrow a.

●Reassembly is to tighten the bolt (1) first, then pre-tighten the bolt (2). The bolt (2) head should be coated with a proper amount of thread fastening glue. After tightening the bolt (2), it is necessary to confirm whether the pedal rotation is flexible or not.

●From June 16, 2020, when purchasing the ZT310-V rear footrest bracket for the old users, you must also purchase a 1274200-286000 ZT310-V rear footrest top plate hinge pin (15).

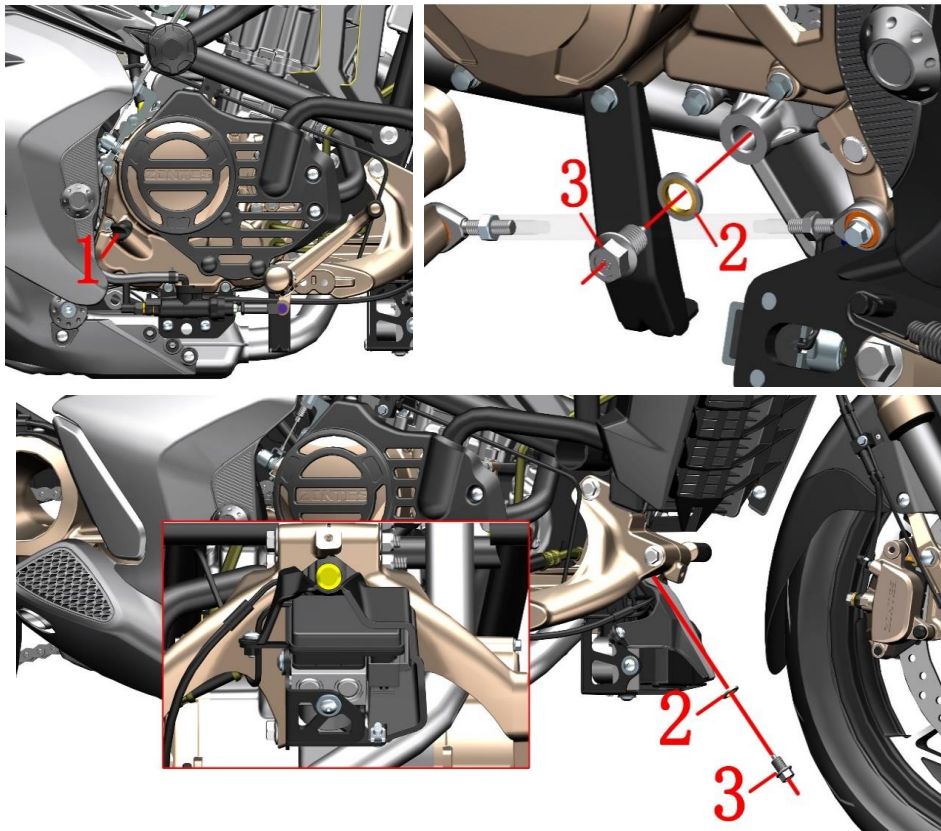

Fig.1 COOLING SYSTEM COMPONENT		Change engine oil	CHK	⚠
			ADJ	
NO.	PART NO.	PART NAME	QTY	CAUTION
1	1050854-002000	ZT180MN Engine oil level gauge	1	
2	1244100-033000	Sealing gasket 12×φ20×2	2	
3	1251100-066093	M12×1.5×15 Oil draining bolt	2	24N.m

PROCEDURE:

● Drain off the engine oil

First remove the lower shroud assembly. Drain with a suitable tool to prevent oil from contaminating the cover. Park the motorcycle with side stand on flat ground.

Rotate the engine oil level gauge (1) anticlockwise and take it out.

Place the oil pan under the frame drain bolt and the engine drain bolt.

Disassemble draining bolts (3) on the chassis and the engine. Take off sealing gasket (2). Drain thoroughly the engine oil.

The frame oil drain bolt is in the gap between the front foot pedal bracket and the ABS pilot control unit cover.

Wipe off the dirty oil with clean nonwovens. Be sure that the surface of oil draining bolt and sealing gasket are not scratched and has no impurity before reassembling. Torque on bolt is 24±4N.m. Too strong will damage the thread. Too weak will cause leakage of oil.

Add from opening on right crankcase of engine 1.6L (1.7L if oil filter is changed) new engine oil of SAE 10W-50/10W-40 with API SM degree or higher. Then reassemble the engine oil gauge.

Start the engine and test it under different rotation speed for 2 minutes. Check if the engine oil leaks.

Run the engine at idling speed for 5 minutes than shut down the engine for 3 minutes. Check the engine oil level gauge. If oil level is lower than minimum mark, add more engine oil until liquid surface reaches maximum mark. Follow the steps above-mentioned and check again if engine oil leaks.

CAUTION:

● Disassembling the cooling system while the motorcycle is hot is prohibited. Wait until the engine and muffler cool down thoroughly for the manipulation.

● Wasted engine oil should be collected and hand over to qualified facilities for further treatment. Do not pour the oil anywhere and avoid pollution of environment and water source.

● Changing the draining bolt and sealing gasket every time when changing the engine oil is suggested.

● As the crankshaft connection rot has bearing bush, while changing the engine oil, make sure the engine has at least 1L before starting the engine. If not, the bearing bush can be damaged or the crankshaft can be seized.

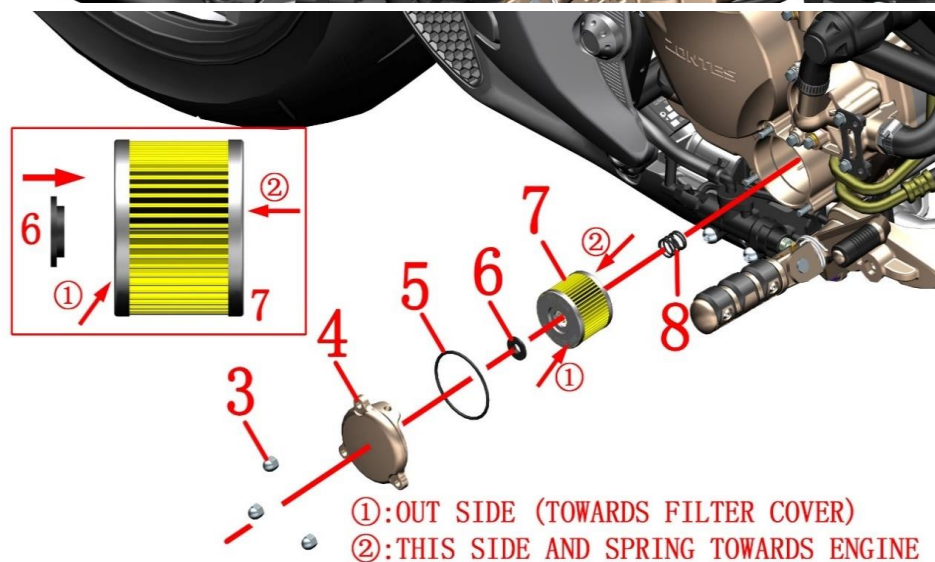
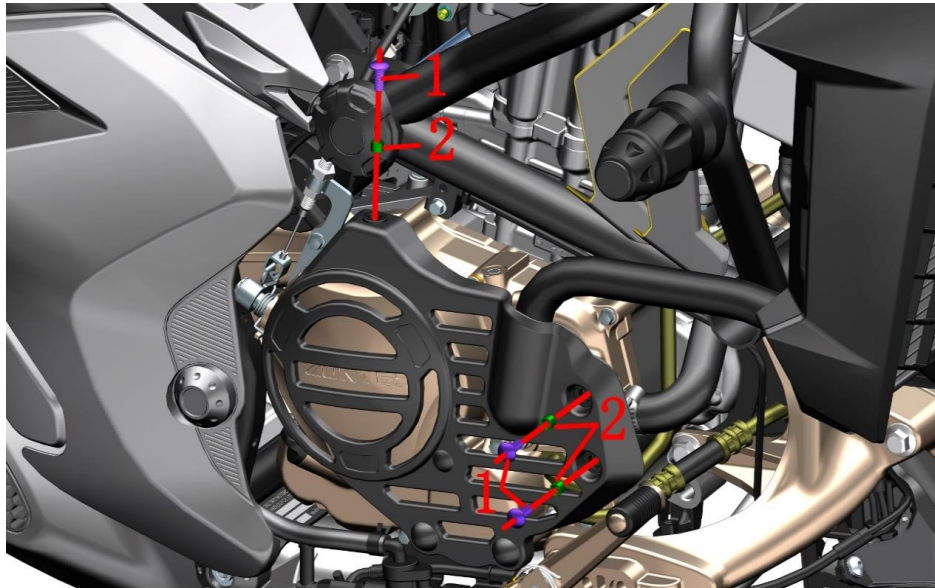

Fig.2 COOLING SYSTEM COMPONENT		Change engine oil filter	CHK	⚠
			ADJ	
NO.	PART NO.	PART NAME	QTY	CAUTION
1	1251100-102000	non-standard bolt M6×16 (304 stainless steel)	3	
2	1274100-018000	anti-hot plate sleeve, muffler	3	
3		M6 Cover type 9 degree nut	3	12±1.5N.m
4	4050954-002000	ZT180MN Engine oil refined filter cover (Titanium)	1	
5	1051454-004000	55×2.5 O-ring	1	after-sale
6	1051454-005000	ZT180MN Engine oil refined filter seal ring	1	
7		ZT180MN fine filter sealing assembly(carton packaging)	1	【1】
8	1050853-009000	Φ16.4×17×1.6 Spring for filter	1	

PROCEDURE:

● Engine decorative cover assembly

Remove 3 pieces bolts (1) respectively, after taking off the bushing (2), and take off the engine decorative cover assembly.

● Change engine oil filter

Place holder to collect wasted engine oil under right crankcase cover.

Disassemble nut (3) with tool. Rotate slightly engine oil refined filter cover (4) and take it off when it is loosen. Take off seal ring (6). Change engine oil filter (7).

Check if seal ring (5) is broken. Change the seal ring (3) along with engine oil filter is suggested.

When reassembling, please check carefully if the spring (8), seal ring (6) are well installed. Engine oil filter can not be turned over when assembling.

Torque of cover type nut (3) is 12±1.5N.m.

CAUTION:

● Ensure every component is well assembled.

● To change engine oil filter and seal ring (5) at the same time is suggested.

● Engine oil filter can not be turned over when assembling.

● Note that the seal ring (6) is facing the fine filter with the “OUT SIDE (TOWARDS FILTER COVER)” side. It is forbidden to install reverse or leak.

● 【1】 The ZT180 refined filter seal component already included oil filter、55×2.5 O-ring (5) and ZT180MN Engine oil refined filter seal ring (6).

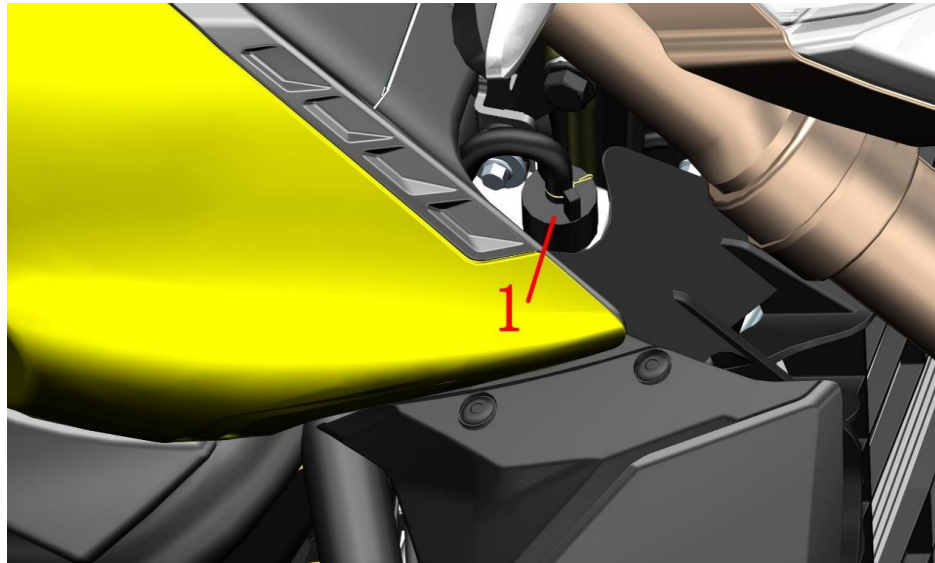

Fig.3 COOLING SYSTEM COMPONENT		Add coolant	CHK	
NO.	PART NO.		ADJ	
1	1274200-188001	ZT310-V sub-water tank	1	

PROCEDURE:

●Add coolant

When the engine is completely cooled, the vehicle can be straightened to accurately check the liquid level. If it is lower than the "L" line, the coolant should be replenished in time. If the auxiliary tank has no or only a small amount of coolant, check the cooling system first, and remove the leak before adding it.

Park the vehicle with the side brackets; turn the direction to the right and turn to the bottom.

Open the lid of the sub tank (1) and add a small amount of coolant each time with a funnel. It is appropriate to reach the position of the F line when the liquid level of the coolant is used to support the vehicle.

CAUTION:

- Check regularly the cooling liquid surface. It should never be lower than "L" line.
- Change cooling liquid every two years is suggested.
- Swallowing or inhaling cooling liquid would harm human body. Clean thoroughly the hands, face or exposing skin every time after adding cooling liquid. If cooling liquid is swalled by accident, please contact toxication center or hosipital. If it's inhaled, please move to open air. If it's spilt to the eye, clean it with big quantity of clean water and see doctor in time. Be sure the cooling liquid is far away from children or pets.
- Engine cooling liquid must be suitable for aluminum radiator. The basic should be glycol. Cooling liquid should be mixture of distilled water and concentrated cooling liquid under certain proportion. Be sure to choose cooling liquid which is suitable for your local extreamly low temperature. The freezing point should be lower than the local lowest temperature. Distilled water is the only kind of water acceptable. Other kind of water might cause corrosion to engine cooling system or other more severe problems.
- Total volume of cooling liquid is 1580ml.
- Cooling liquid might damage the coating of motorcycle. Be careful while adding. If it is spilt in small quantity, please clean it immediately with soft cloth.

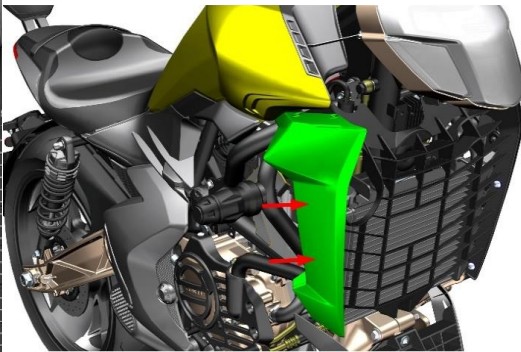
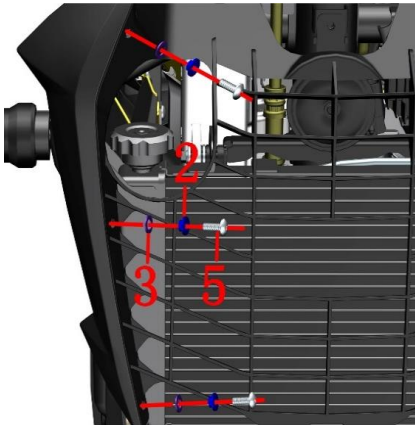
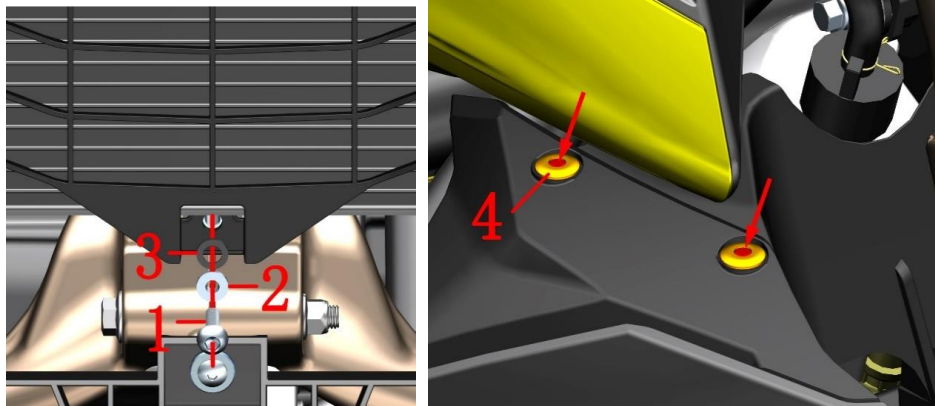

Fig.4 COOLING SYSTEM COMPONENT		Radiator covercomponent 1	CHK	CAUTION
NO.	PART NO.	PART NAME	ADJ	
1	1251100-364000	Non-standard bolt M6×25(color/10.9 grade)	1	
2	1274100-155095	Flanged bushing φ6.2×φ8.4×3.5+φ14×1.5(5 pcs/after-	4	
3	1241200-124021	flanging bushing buffer rubber (φ8.5×φ14×1)(5 pcs/aft	4	
4	1224100-089000	ZT250-S Expansion nail(5 pcs/after-sale)	2	
5	1251100-102000	non-standard bolt M6×16 (304 stainless steel)	3	

PROCEDURE:

● Radiator decorative cover assembly

Remove the bolt (1) under the middle part of decorative cover and upper part of pedal bracket, take off bushing (2) and buffer rubber (3).

Remove the expansion pin after pressing the intermediate part of the expansion screw (4).
Turn the front of the car to the left.

Remove 3 bolts (5), take off the bushing (2) and buffer rubber (3).

Grab the right side of the trim cover and pull it out as indicated by the green arrow at the arrow.

Grab the same part of the left side of the trim cover and pull it out.

CAUTION:

- Pull out hard directly when pulling out, and do not shake it to the sides to prevent damage to the staples.
- Pay attention to the surface of the material.
- Disassemble the engine and radiator after they have been completely cooled.

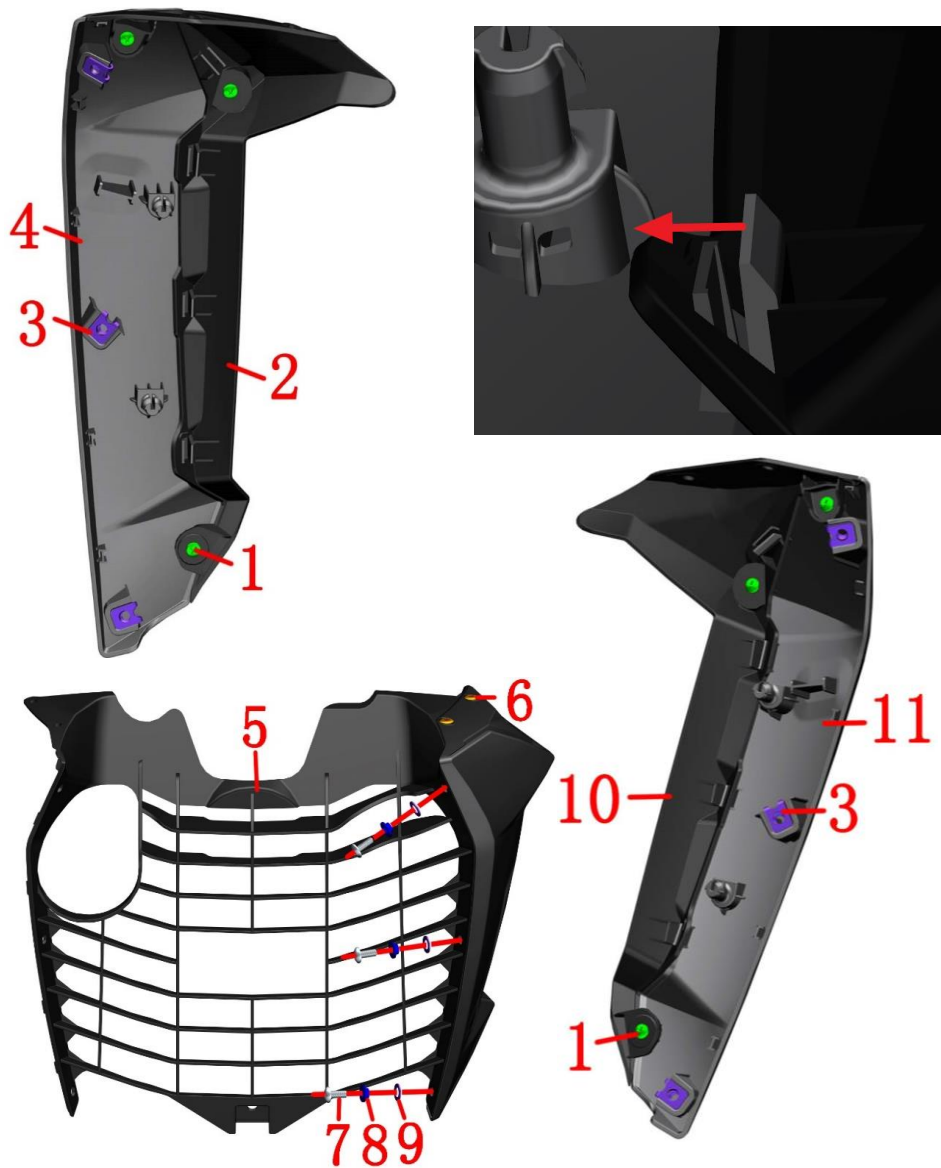

Fig.5 COOLING SYSTEM COMPONENT		Radiator covercomponent 2	CHK	⚠
NO.	PART NO.	PART NAME	ADJ	
1	1251200-038093	Non-standard self-tapping screwST3.9×12(zinc)	6	CAUTION
2	1224200-116000	ZT310-v radiator trim cover right rear part	1	
3	1251300-063093	plywood M6×11×15 (color zinc)	6	
4	4044201-245052	ZT310-v radiator decorative cover front right (dark grey)	1	
5	1224200-114000	ZT310-v radiator trim cover center	1	
6	1224100-089000	ZT250-S Expansion nail(5 pcs/after-sale)	2	
7	1251100-102000	non-standard bolt M6×16 (304 stainless steel)	3	
8	1274100-155095	Flanged bushing φ6.2×φ8.4×3.5+φ14×1.5(5 pcs/after-	3	
9	1241200-124021	flanging bushing buffer rubber (φ8.5×φ14×1)(5 pcs/af	3	
10	1224200-115000	ZT310-V radiator trim cover left rear	1	
11	4044201-244052	ZT310-V radiator trim cover front left (dark grey)	1	

PROCEDURE:

● Radiator decorative cover assembly

Remove the self-tapping screws (1), and pry the four snaps in the direction indicated by the arrow to separate the right rear part (2) and the right front part (4). Remove the 3 plywood nuts (3) from the right front.

Remove the expansion pin after pressing the intermediate part of the expansion screw (6).

Remove the 3 bolts (7), remove the bushing (8) and the cushion rubber (9) and remove the middle part (5).

Remove the left rear part (10) and the left front part (11) of the trim cover by referring to the previous steps.

CAUTION:

● Pay attention to the surface of the material.

● When reassembling, be careful to first set the self-tapping screws perpendicular to the mounting surface and not to use excessive torque.

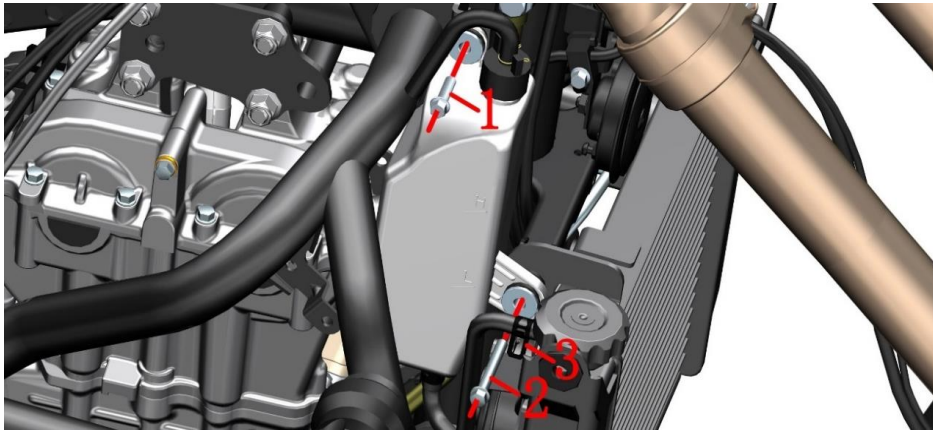
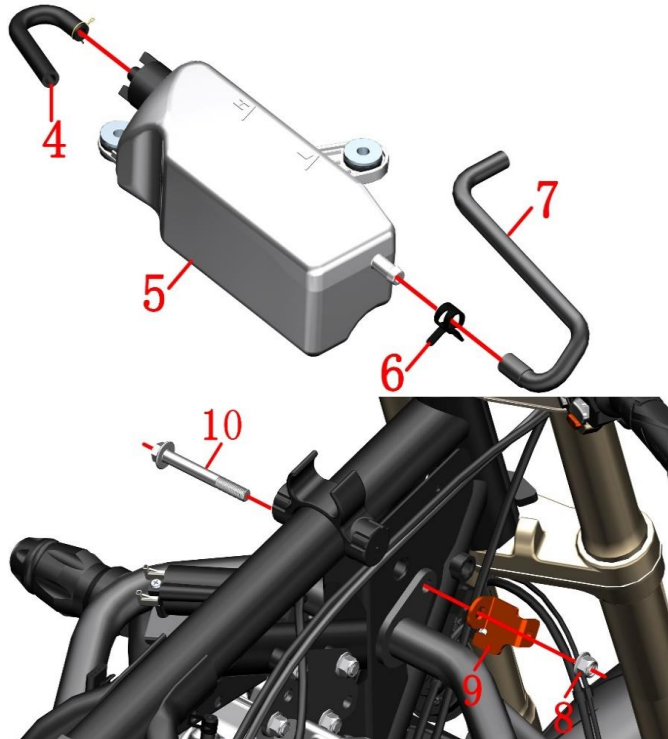

Fig.6 COOLING SYSTEM COMPONENT		Vice water tank components	CHK	⚠
			ADJ	
NO.	PART NO.	PART NAME	QTY	CAUTION
1	1251100-061093	M6×22 Hex flang bolt thread level 8.8 (color zinc)	1	
2	1251112-003093	M6×45 Hex flange surface 9.8 bolt (color zinc)	1	
3	1276001-056000	ZT310 water pipe clamp(φ9)(after-sale)	1	
4	1244200-069000	ZT310-V sub water tank leakage pipe	1	
5	1274200-188001	ZT310-V sub water tank	1	
6	1276001-057000	ZT310 water pipe clamp(φ10.5)(after-sale)	1	
7	1244200-070000	ZT310-V Sub water tank connection pipe	1	
8	1251300-057093	non-standard nuts M10×1.5 (color zinc)	1	
9	1274200-184000	ZT310-V sub water tank bracket	1	
10	1251100-132003	non-standard bolt M10×1.5×80	1	



PROCEDURE:

● sub water tank assembly

Remove the bolts (1) and (2), pull the sub tank assembly out of the gap.

After wearing the waterproof rubber gloves, put the sub tank assembly upside down (the sub water tank cover down) into a plastic container.

After clamping the hoop (3) with pliers, pull the water pipe out of the main tank and remove the hoop (3).

Vent the coolant in the secondary tank.

Clamp the clamp on the leak pipe (4) with pliers and pull it out. Subsequent production of motorcycles will reduce the clamps for leak pipe.

Clamp the hoop (6) with pliers and pull the water pipe (7) out of the sub tank (5), then remove the hoop (6).

● Sub water tank bracket.

If it is necessary to remove the auxiliary tank bracket, fix the nut (8) with the sleeve by using the sleeve to fix the head of the bolt (10).

Remove the sub tank bracket (9) after pulling out the bolt (10).

CAUTION:

● Disassembling the cooling system while the motorcycle is hot is prohibited. Wait until the engine and muffler cool down thoroughly for the manipulation.

● Cooling liquid should be collected and hand over to qualified facilities for further treatment. Do not pour the oil anywhere and avoid pollution of environment and water source.

● Be sure to wipe the connecting surface with clean nonwoven before reassembling.

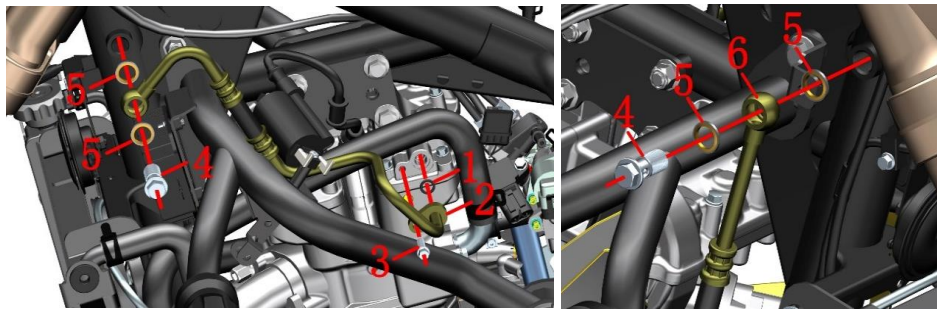

A

B

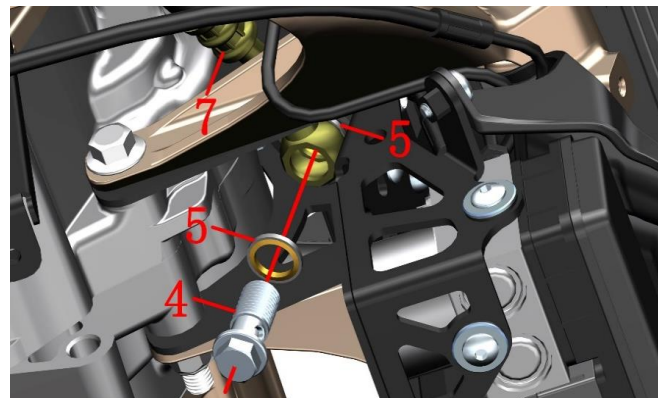

C

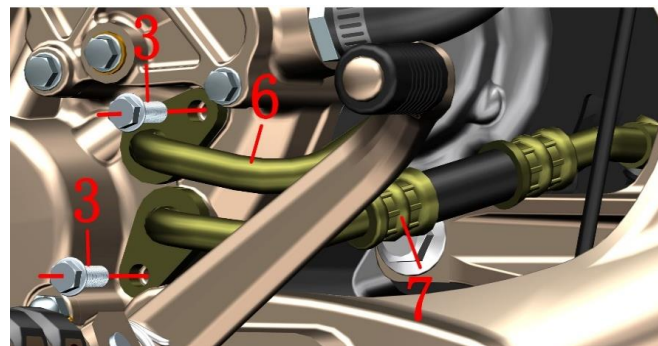

D

Fig.7 COOLING SYSTEM COMPONENT		Radiator tubing component		CHK	CAUTION
NO.	PART NO.	PART NAME	QTY	ADJ	
1	1051454-014000	9.8×2.5 acrylic o-ring	3		
2	1274200-186000	ZT310-V Frame bypass oil pipe	1		
3	1251100-061093	M6×22 Hex flang bolt thread level 8.8 (color zinc)	3		
4	1251100-089094	oil bolt M14×1.50×32	3		30±2N.m
5	1244100-034000	combined sealing gasket φ14×φ20×2	6		
6	1274200-189000	ZT310-V Engine outlet oil pipe	1		
7	1244200-015000	ZT310-R Engine inlet oil pipe	1		

PROCEDURE:

- Chassis connected oil tube
Disassemble oil passing bolt (4), take off 2 pieces combination seal (5), pictured A.
Disassemble bolt (3) close to engine with socket sleeve. Disassemble chassis connected oil tube. Take off O-ring
- Engine oil outlet tube
Disassemble oil passing bolt (4), Remove 2 seal gasket (5) with socket sleeve, pictured B
Disassemble oil passing bolt (4), seal gasket (5) with socket sleeve, pictured C
Disassemble bolt (3) with socket sleeve. Take off engine oil outlet tube (6), engine oil intake tube (7), pictured D.
The oil outlet pipe (6) and the oil inlet pipe (7), Remove 2 o-ring (1).

E

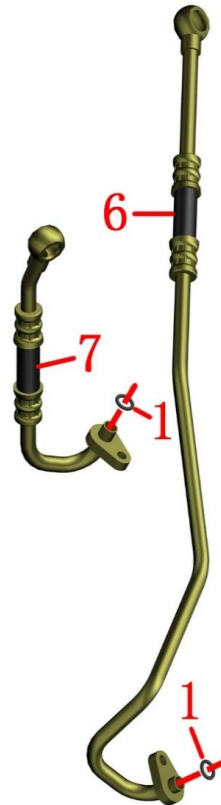

CAUTION:

- Disassembling the cooling system while the motorcycle is hot is prohibited. Wait until the engine and muffler cool down thoroughly for the manipulation.
- Wasted engine oil should be collected and hand over to qualified facilities for further treatment. Do not pour the oil anywhere and avoid pollution of environment and water source.
- Do not disassemble the oil tube violently in case of deformation of bush.
- To avoid leakage, changing seal gasket and O-ring every time together with engine oil is suggested.
- Be sure to wipe the connecting surface with clean nonwoven before reassembling.

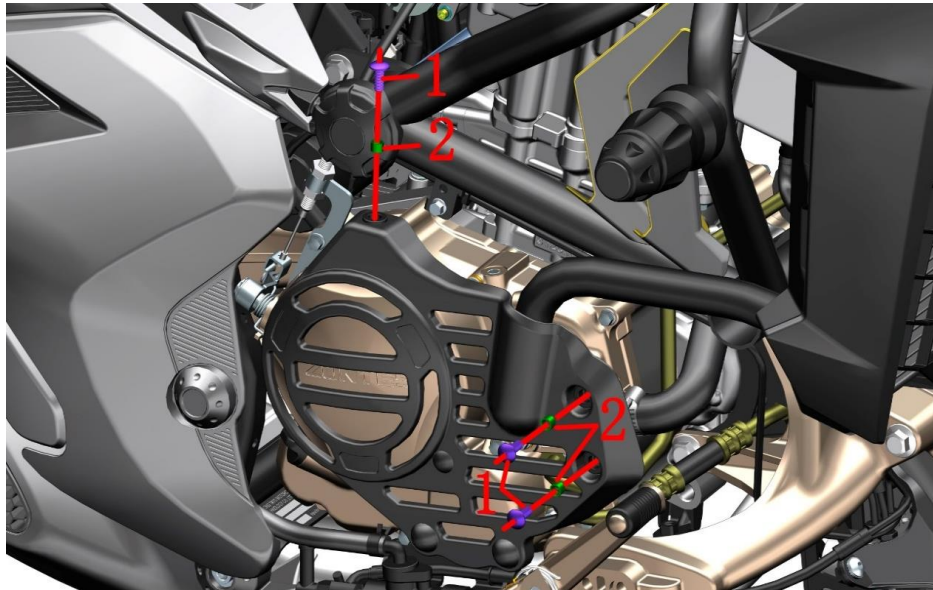
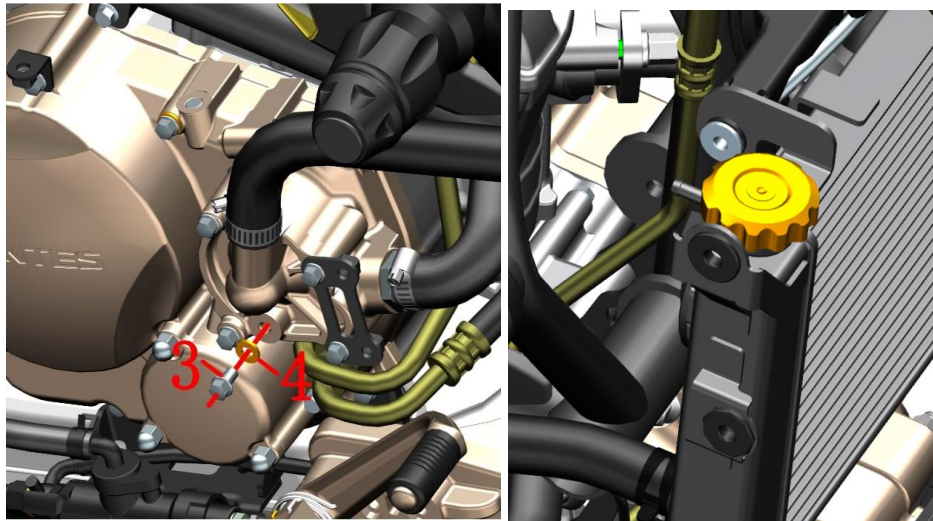

Fig8 COOLING SYSTEM COMPONENT		Draining cooling liquid	CHK	⚠
			ADJ	
NO.	PART NO.	PART NAME	QTY	CAUTION
1	1251100-102000	Non-standard bolt M6×16(304 stainless steel)	3	
2	1274100-018000	ZT250-S muffler anti-scalding bushing	3	
3	1251112-001093	M6×16 Hex flange bolt (environmental color zinc)	1	
4	1051654-002000	Seal gasketφ6×13×1.8	1	

PROCEDURE:

- Engine decorative cover assembly
Remove 3 bolts (1) respectively, after taking off bushing (2) and take off engine decorative cover assembly.
- Drain the cooling liquid
Refer to the previous “Sub tank assembly” procedure to vent the coolant in the sub tank.
After placing the oil pan or other container under the right side of the vehicle, tilt the vehicle to the right.
After wearing waterproof gloves with both hands, remove the bolts (3) with a sleeve and remove the combination seal (4).
Drain the coolant with a funnel or other device.open the cooling liquid tank cover to accelerate the draining of cooling liquid in the cooling system.
Wipe out all of the cooling liquid on surface every component with a clean cloth.



CAUTION:

- Motorcycle should be well supported.
- Manipulation should start after the engine is completely cooled down.
- Cooling liquid is toxic. Avoid strictly eye or skin contact.

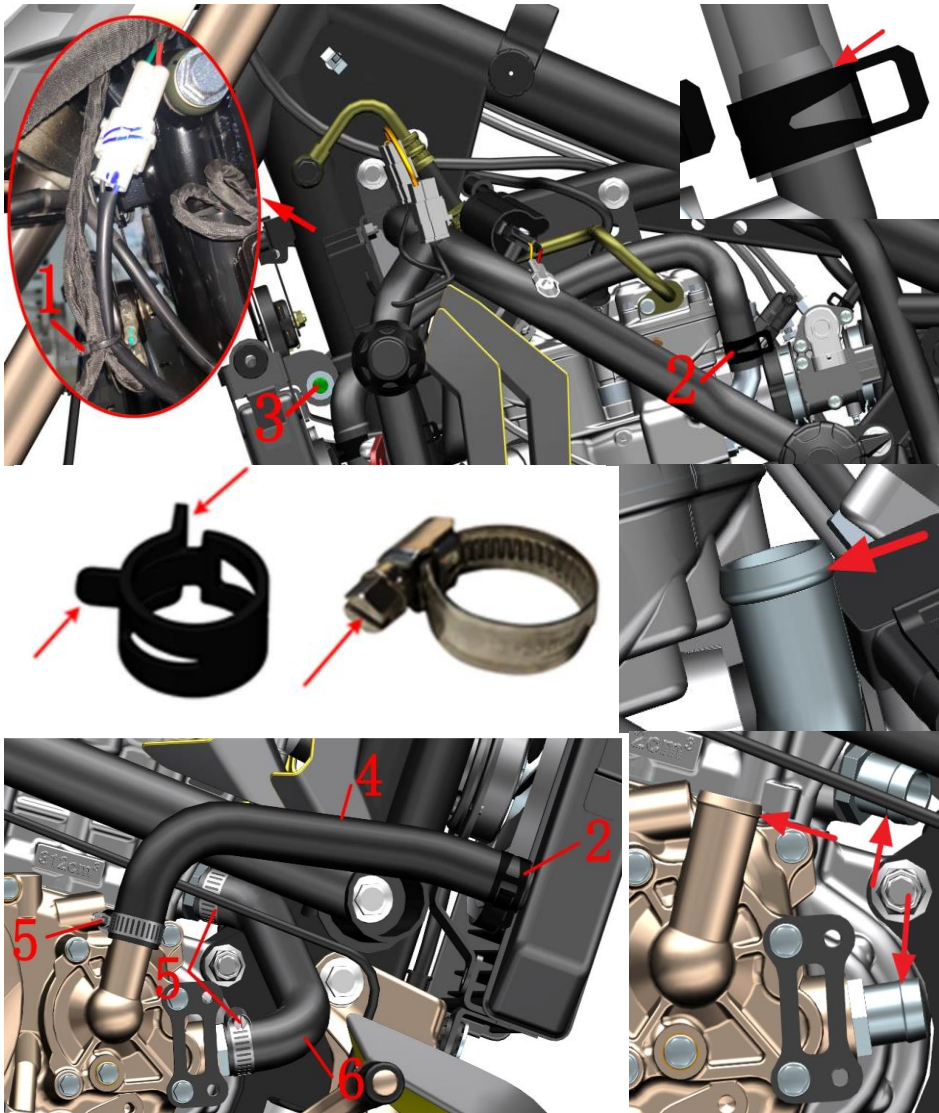

Fig.9 COOLING SYSTEM COMPONENT		Main water tank assembly 1	CHK	⚠
			ADJ	
NO.	PART NO.	PART NAME	QTY	CAUTION
1	1226000-218000	Grade 0 flame retardant tie (black 3.6×295)(5 pcs/after-	2	
2	1274200-090000	ZT310 Hoop of cooling liquid tube (φ26)	2	
3	1251112-002093	M6×30 Hexagon flange bolts (color zinc)	1	
4	1244200-068000	ZT310-R engine inlet water pipe	1	
5	1276001-055000	ZT310 Water pipe clamp (φ26)(after-sale)	3	
6	1244200-012000	ZT310—R Engine cooling liquid passing tube	1	

PROCEDURE:

● Main water tank assembly

Locate the connector for the radiator fan and temperature sensor on the left side of the vehicle near the front of the tank and unplug the connector.

Cut the two straps (1).

Use the pliers to clamp the hoop (2) and move the anti-slip boss up to release the hoop.

Remove the bolt (3).

Pull out the water pipe after wearing the waterproof gloves. Remove the hoop (2).

Use the pliers to remove the hoop (2) on the right side and pull out the engine inlet pipe (4). Close the radiator end and remove the hoop.

Use a flat-blade screwdriver to loosen the three clamps (5) and remove the boss indicated by the arrow.

Remove the inlet pipe (4) and the water pipe (6) and then remove the clamp (5) from the water pipe.

Remove the main tank assembly.

CAUTION:

- Motorcycle should be well supported. Manipulation should start after the engine is completely cooled down.
- 【1】 used for sliding clutch engine. 【2】 used for ordinary clutch engine.
- When reassembling, be careful that the clamps and hoops should be prevented from loosening on the inside of the boss.

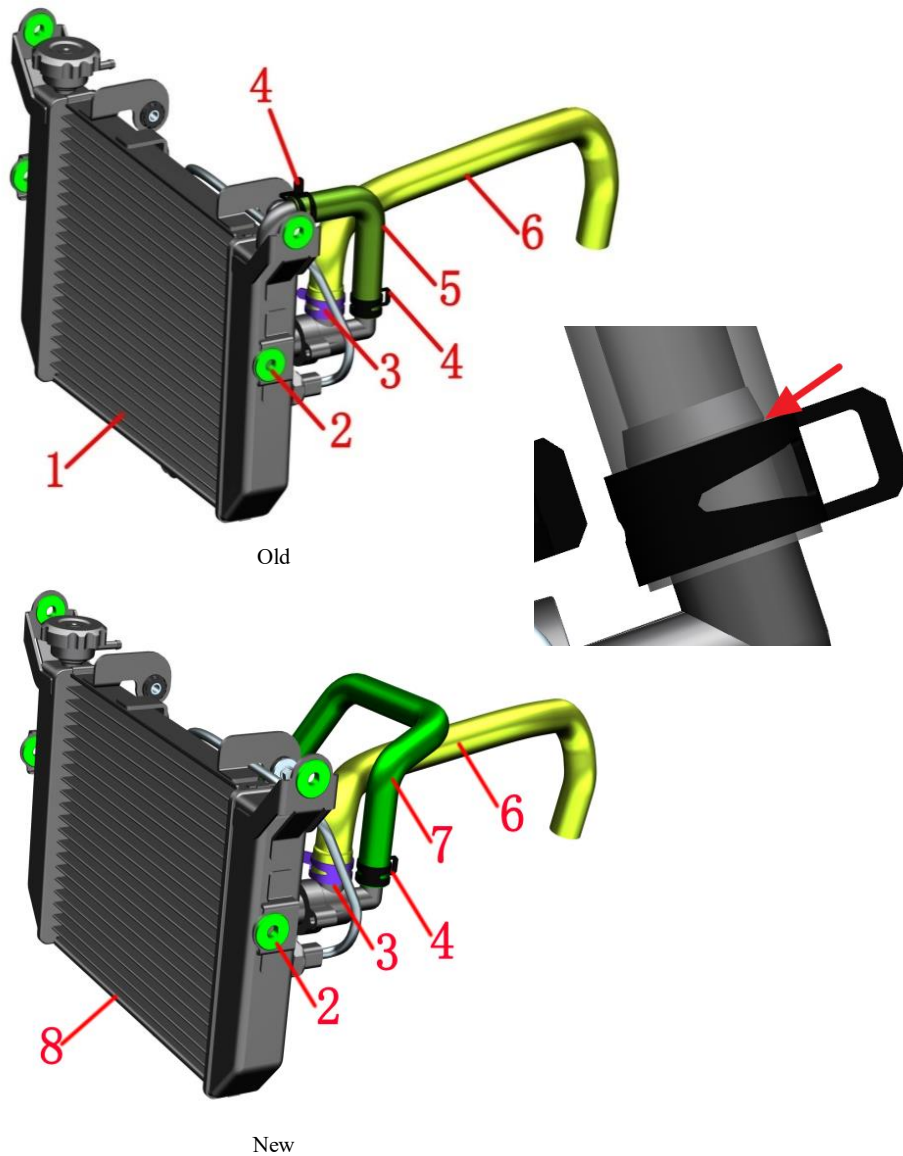

Fig.10 COOLING SYSTEM COMPONENT		Main water tank assembly 2	CHK	⚠
			ADJ	
NO.	PART NO.	PART NAME	QTY	CAUTION
1	1274200-187021	ZT310-V Main water tank	1	
2	1244100-138000	ZT250-S Side cover round rubber(5 pcs/after-sale)	4	
3	1274200-091000	ZT310 water pipe clamp (φ27)	1	
4	1274200-089000	ZT310 water pipe clamp (φ22)	2	
5	1244200-067000	ZT310-V small circulation water pipe	1	
6	1244200-071000	ZT310-V engine outlet water pipe	1	
7	1244200-113000	ZT310-V small circulation water pipe(right return water)	1	
8	1274200-267021	ZT310-V Main water tank(right return water)	1	

PROCEDURE:

●Main tank assembly

Remove 4 pieces of side cover round glue (2) from the main water tank (1) or (8).

After wearing the waterproof gloves, clamp the hoop with pliers (4) and remove the hoop after removing the anti-slip boss.

Remove the small circulation water pipe (5) or (7) and take off the two hoops (4).

Remove the outlet pipe (6) and the hoop (3) as previously described.

CAUTION:

●Cooling liquid is toxic. Avoid strictly eye or skin contact.

●Do not disassemble the hoop with too strong force. If not, it will cause permanent deformation and lose elasticity, which will lead to leakage of cooling liquid.

●From May 14, 2020, the new main water tank will be switched, and the old water tank will be discontinued. You need to purchase the "1274200-267021 ZT310-V main water tank (with temperature control switch / right small return water)" and "1244200-113000 ZT310 -V small circulation water pipe (right return water)".

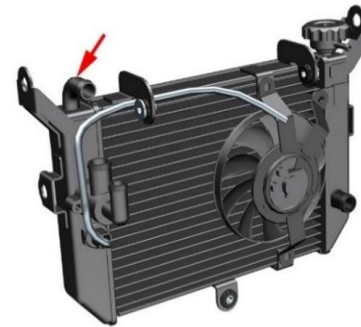

Old



New

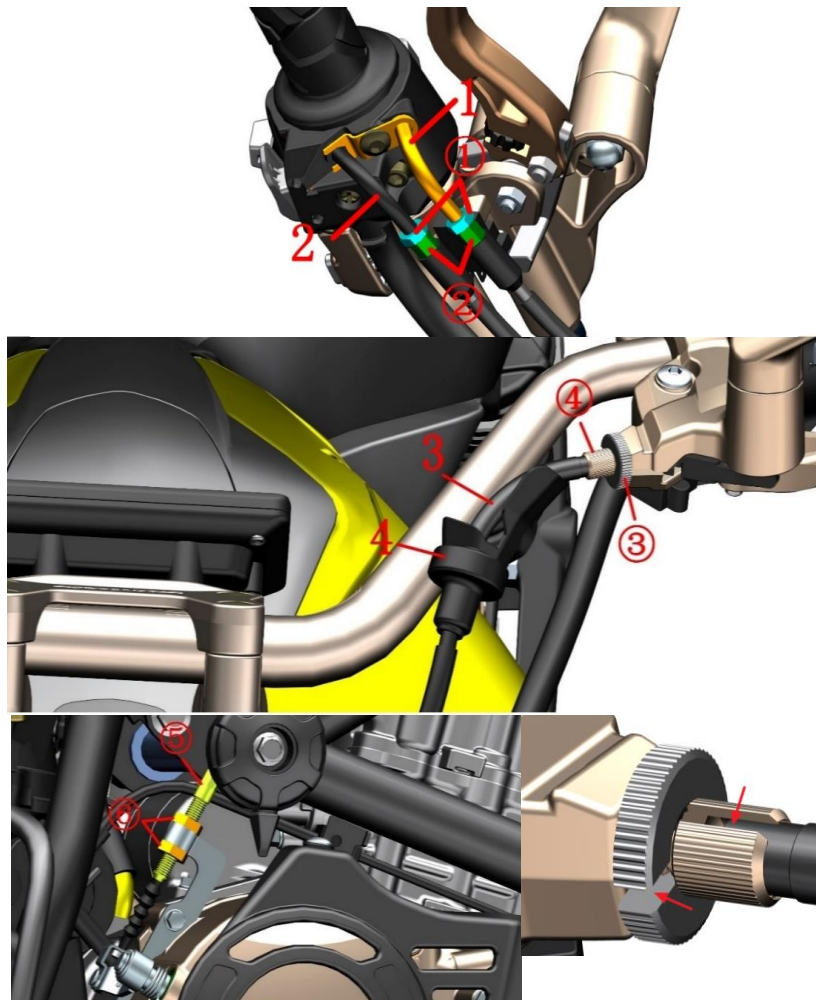

Fig.1 FRONT FORK COMPONENT		Throttle/clutch cable clearance adjustment		CHK	CAUTION
				ADJ	
NO.	PART NO.	PART NAME		QTY	
1		Throttle Refueling Line		1	
2		Throttle Return Line		1	
3		Clutch cable		1	
4	1244200-046000	ZT310-V clutch line sheath		1	

PROCEDURE:

● Throttle line

Use an open-end wrench to loosen the lock nut ① on the throttle refueling line (1) or the return line (2), and turn the adjustment screw ② to adjust the clearance to 2 to 4 mm. After the adjustment, lock the nut ① again.

● Clutch line

Fine adjustment:

Lift the protective rubber sleeve (4) on the clutch rocker arm to the elbow of the clutch cable (3), loosen the nut ③ with pliers, rotate the adjustment screw ④, finally lock the nut ③, and then reset the dust jacket. After adjusting, pay attention to the nut ③, the adjustment screw ④ and the groove of the rocker seat should be staggered to prevent the cable from coming out.

Big adjustment:

If fine adjustment cannot be achieved, loosen the nuts ⑥ with an open-end wrench, rotate the adjustment screw ⑤, and finally tighten the nuts ⑥.

CAUTION:

● The motorcycle support should be fixed during disassembly to prevent accidents caused by incline.

● Throttle line adjustment should be noted as follows:

After adjustment, ensure that the throttle can be reset automatically. It is forbidden to increase the idle speed of the engine due to adjustment of the cable.

The engine idle speed rise cannot occur in the direction of rotation.

Checking the engine idle speed should be performed under the condition of a heat engine and should be at 1500 to 1700 rpm.

● The clutch adjustment should be noted as follows: Excessive free travel can cause wear and malfunction of the clutch and gearshift mechanism. After adjustment, be sure to stagger the nut, adjusting screw, and slot on the rocker arm to a certain position to prevent the cable from coming out of the slot.

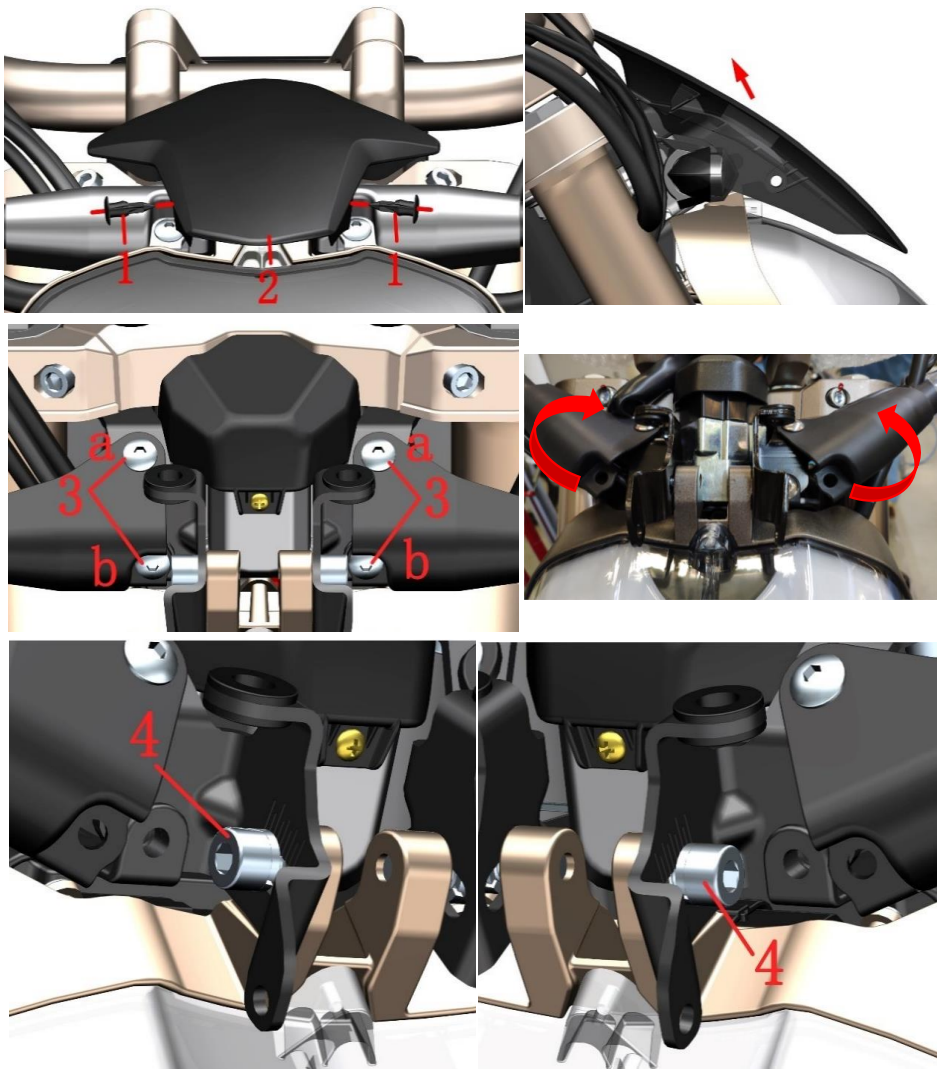

Fig.2 FRONT FORK COMPONENT		Light height adjustment	CHK	
NO.	PART NO.	PART NAME	ADJ	
1	1224100-089000	ZT250-S Expansion nail(5 pcs/after-sale)	2	CAUTION
2	1224200-117000	Decorative hood over ZT310—V headlamp	1	
3	1251100-102000	Non—standard bolt M6×16 (304 stainless steel)	4	
4	1250205-040095	GB70.1 inner hex bolt M8×16 (color Zinc)	2	

PROCEDURE:

●Decorative hood over headlamp

Remove the center of the expansion screw (1) and remove it.

Pull the headlight cover (2) in the direction of the arrow.

●Light height adjustment

Remove the two bolts (3) at b; loosen the two bolts (3) at a. Rotate the two turn signal assemblies up to expose the head of the bolt (4).

The driver rides the motorcycle and the motorcycle is upright. The other person inserts a6#the inner hexagon will loosen the bolts (3) on both sides and adjust the light to the proper position to lock.

Note that tick marks aligned on both sides.

CAUTION:

●Light height adjustment should be noted as follows:

Too High or too low light levels can affect safe driving. The height of the lights should be properly adjusted according to whether there are changes in the weight of the occupants and the driver.

It is forbidden to adjust the light height during riding. It is advisable to adjust the road with a smooth road surface and a straight line distance of about 150 meters without affecting traffic safety at night.

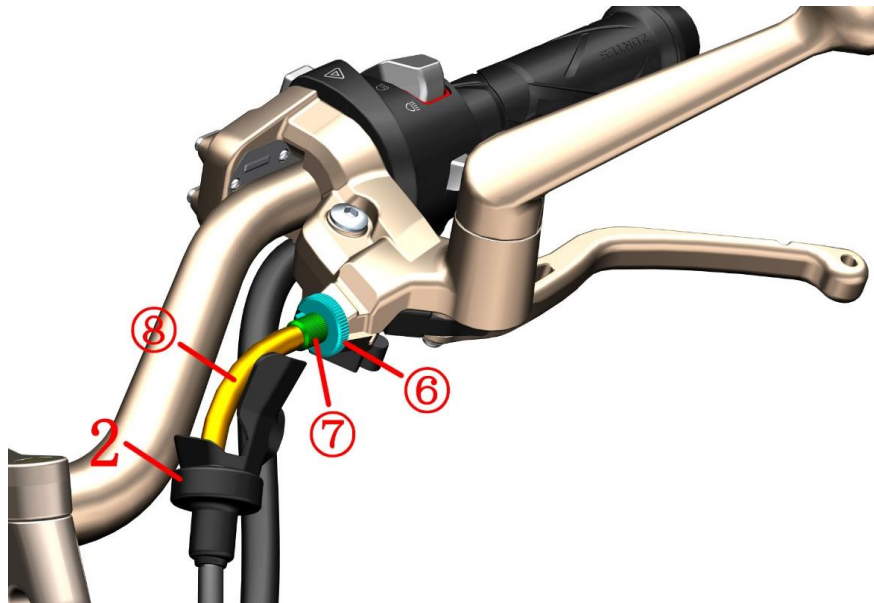
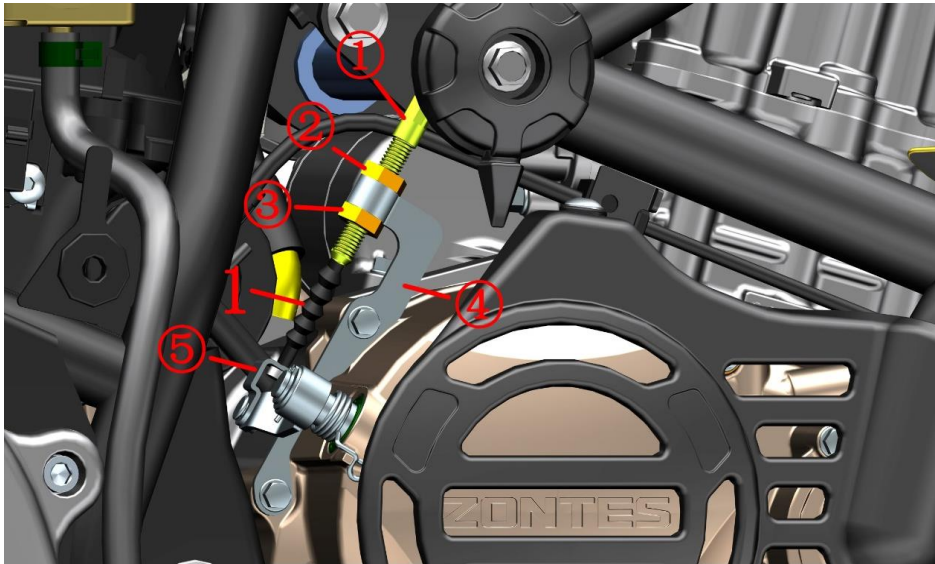

Fig.3 FRONT FORK COMPONENT		Replacement clutch cable		CHK	⚠
NO.	PART NO.	PART NAME	QTY	ADJ	
1		Clutch line	1		
2	1244200-046000	ZT310-V protective rubber sleeve	1		

PROCEDURE:

● Remove the clutch line

Use an open-end wrench to loosen the nuts ② and ③; fix the adjusting screw ①, rotate the nut ② up to the top of the thread of the adjusting screw, and screw the nut ③ to the bottom to completely separate from the thread. Separate the clutch wire core connector from the bracket ⑤, close the nut ③ to the black sheath with one hand, and remove the adjustment screw ① from the bracket ④ with one hand.

First, the protective rubber sleeve (2) is retracted to the elbow ⑧ and the nut ⑥ is loosened with the pliers; the nut ⑥ and the adjusting screw ⑦ are rotated to the same position as the groove on the rocker arm, and remove the cable from the rocker arm seat.

Remove the clutch line.

Remove the protective sleeve (2) from the clutch cable(1).

● Install the clutch line

Put protective rubber sleeve (2) into clutch elbow.

After inserting the clutch cable joint into the rocker arm, screw the nut ⑥ and the adjusting screw ⑦ to the groove on the rocker arm.

Assemble the clutch cable into place according to the original alignment.

Rotate the nut ② up to the top of the thread of the adjusting screw, and screw the nut ③ to the bottom to completely separate from the thread.

Take the nut ③ close to the black sheath with one hand and insert the adjustment screw ① into the bracket ④ with one hand.

Insert the clutch core connector into the hole of the bracket ⑤.

Initially position the nut ② first, adjust the free stroke adjustment in the clutch cable adjustment, and then lock the nut ③.

Finally, reset the protective rubber sleeve (2).

CAUTION:

- The motorcycle support should be fixed during disassembly to prevent accidents caused by incline.
- Before replacing the clutch line, it is necessary to disassemble the seat cushion, fuel tank, liner, side cover, etc.

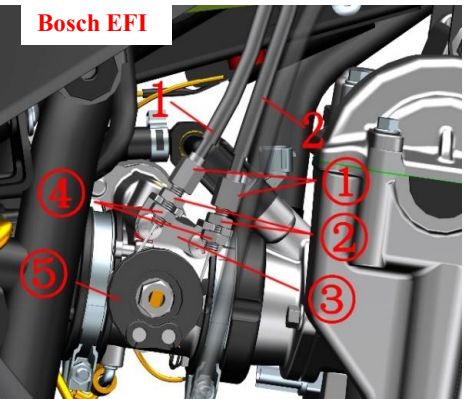
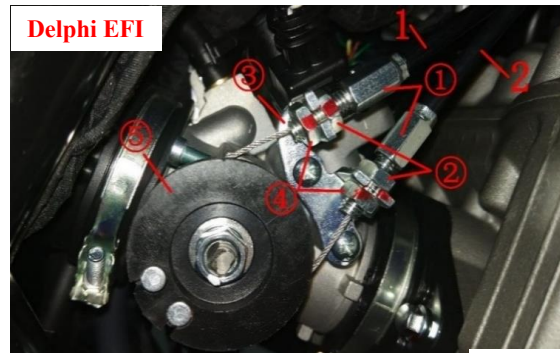

Fig.4 FRONT FORK COMPONENT		Replace the throttle line	CHK	CAUTION
NO.	PART NO.	PART NAME	ADJ	
1		Throttle Refueling	1	
2		Throttle Return Line	1	
3	1224100-030000	Pin tie (Black 4.8×130)	1	
4	1224100-051000	0 Flame retardant tie (black 2.5×100)	1	
5	1244100-140000	ZT250-R right handle bar rubber sleeve(after-sale)	1	
6		Right handlebar switch	1	
7	1250205-031091	GB70.1M6×30 (stainless steel)	2	
8		Right handlebar switch	1	

PROCEDURE:

●Disassemble the throttle line

Use 10# an open-ended wrench to screw the nut ② of the accelerator oil line (1) up to the bottom, and screw the nut ④ down out of the adjusting pipe ①; Remove the cylindrical joint of the oil filling line from the rotary table ⑤; Referring to the previous steps, first completely loosen the nuts ② and ④ of the oil return line (2), remove the cylindrical joint from the rotary table, and then move the adjusting pipe of the oil return line (2) upward, over the bracket ③ on the throttle valve, and then pull it out. Pass the throttle line out of the slot of the plug strap (3) and do not cut the strap (3). Find the cable tie (4) on the right side of the body and cut it. Loosen the bolts (7); remove the sub switch (8) and the right brake rocker arm assembly (8) in the direction of the arrow and lock the bolt (7). Always keep disc brake main pump (8) high. Hold the right hand switch (6) with your hand and remove the bolts (6) and (7) before removing the bolt (9). Switch the upper and lower parts of the switch. Remove the throttle cable from the right hand and remove the rubber sleeve (5) from the core turntable ⑩, and then remove it from the cable hole in the lower part of the switch.

●Install the throttle line

First pass the throttle cable into the cable hole in the lower part of the switch. Fit the cylindrical connector of the throttle cable into the turntable ⑩ on the right hand gripper. Return the oil return line card to the limit slot provided on the fuel line. Lock the bolt (6) to a torque of 8 to 10 Nm. The switch mounting hole is slightly twisted a few times for the rear bolt(7) and the bolt(9) is locked after observing the positioning hole and the direction of the lower part of the switch (6). Finally, tighten the bolt (7) and tie the tie (4). Cut off the excess. Reset the sub switch and rocker assembly and note the symbol on the alignment switch. Install the throttle cable into the slot of the hub clamp (3). Turn the nut (2) of the throttle refueling line (1) or the return line (2) up to the end, and turn the nut (4) downwards to the adjustment pipe (1). Put the oil return line into the bracket (3), and fit the connector into the turntable (5). Put the oil line into the bracket (3), then turn the turntable (5) to a certain angle, and then insert the connector. Refer to the method of adjusting the gap to adjust the throttle line clearance; after adjusting the left and right direction of rotation, there should be no change in idle speed and flexible reset. Lock nuts (2) and (4).

CAUTION:

- The insertion of the plug strap head into the frame reinforcement plate hole is a non-detachable structure, so it is difficult to replace after cutting. Therefore, the cable tie cannot be cut.
- The old model will be discontinued; the old switch can be replaced directly with the new one.



Fig.5 FRONT FORK COMPONENT		Steering adjustment	CHK	⚠
			ADJ	
NO.	PART NO.	PART NAME	QTY	CAUTION
1	1251300-045000	ZT250-S Upper connection plate decorative nut	1	100N·m
2	1251500-050000	ZT250-S Upper connection plate gasket $\phi 18.5 \times \phi 39 \times 1$	1	
3	1250205-034093	GB70.1 Hexagon M8×30 (color zinc)	2	22~24N.m
4	1134100-040000	ZT250-S Adjusting nut locking washer(5 pcs/after-sale)	1	
5	1251300-046093	ZT250-S Direction column adjusting nut M24X1	2	
6	1244100-135000	ZT250-S Adjusting nut rubber gasket (5 pcs/after-sale)	1	
7	1244300-014000	ZT350-R upper dust cover	1	
8	1130900-053000	ZT250-S shaft ring (after-sale)	1	
9	1130900-054000	ZT250-S conjoined steel ball (5 pcs/after-sale)	2	
10	1130900-052000	ZT250-S upper steel bowl (after-sale)	2	

PROCEDURE:

- When the front fork is slightly swaying or when the direction handle is swung

Check if the pressure of the front tire is the recommended air pressure at room temperature: 250 kPa.

If it is lower than the recommended air pressure, the front tire pressure should be inflated to 350 kPa first, and then deflated to 250kPa. If it is otherwise set the front wheel and turn to inspect the tire tread, if it is worn or deformed, the front tire needs to be replaced. If no, continue to operate.

- Check steering device

Set up the front wheel and shake the lower part of the fork by hand to check if the steering shaft is loose or if the left and right rotations are not flexible.

Adjust the adjustment nut:

Remove the trim nut (1) with a spanner, remove the spacer (2), and remove the bolt (3) with the Allen tool. The direction of the upper board assembly wrapped with a clean cloth and then placed to prevent scratches. Remove the lock washer (4); remove the upper adjustment nut (5) with a special four-jaw shank or hook wrench and remove the pad (6).

If the steering resistance is too large, turn the lower adjustment nut (5) counterclockwise. If the brake is slightly swaying or swings, rotate clockwise. The torque is about 14N.m. It is appropriate.

When reassembling, the top adjusting nut only needs to be screwed to align with the bottom nut groove, so as not to over-tighten to avoid excessive deformation of the pad (6); the torque requirement of the decorative nut (1) is 100 Nm.

- Steering bearing

If the above operation still can not rule out excessive steering resistance or stuck as follows:

Remove the adjusting nut (5), remove the upper dust cover (7), shaft ring (8), and connecting ball (9), remove the directional column & front shock absorber & front wheel assembly, and check the shaft ring and the connecting steel ball for abnormal wear or rust. At the same time, inspect the seat ring (10) in the standpipe in front of the frame for abnormal wear or rust. The newly replaced conjoined steel ball should be evenly greased, pay attention to the amount of grease.

CAUTION:

- If the steering is adjusted too tightly, the steering force will be greater. If the steering is too loose, the front of the motorcycle will be slightly shaken during braking, and adjustments must be made according to the actual needs of the driver.

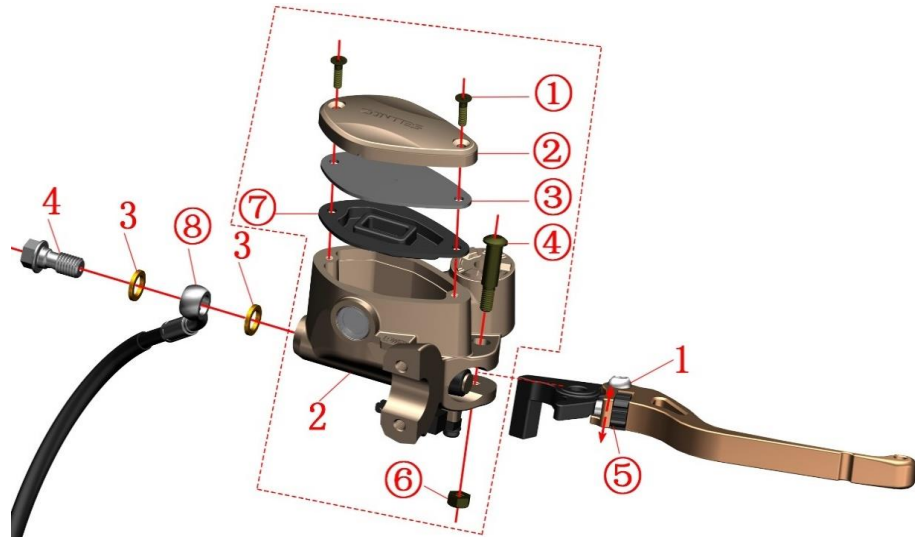
**PROCEDURE:**

● Front disc brake main pump

Fix the front disc brake main pump, remove the bolt (4) and copper pad (3) with the sleeve, and do not disassemble if it does not need to be replaced. Always replace the tubing connector (8) at a high level to prevent air from entering the tubing and cause brake failure. Also clean oil should be removed to prevent dripping onto parts such as covers or mufflers. After replacement, be sure to continuously hold the swing arm(1) and tap the disc brake main pump (2) to remove a small amount of gas entering the brake oil circuit, and confirm that the brake is returned to normal.

●Rocker

Rotating the adjusting nut (5) can adjust the distance between the rocker arm and the handle rubber sleeve to adapt to different driver's feel.

If you need to replace the rocker arm, use a hexagon socket tool to fix the bolt (4). Then use a socket or box wrench to remove the nut (6). Remove the bolt(4) and remove the rocker arm (1).

●Add brake fluid

Before driving the motorcycle, check whether the brake fluid level is above the "LOWER" marking. If not, check the brake disc or brake disc for wear and whether there is any oil leakage or oil leakage in the brake system. Abnormal needs to add brake fluid.

The brake fluid can only be added after the motorcycle is fixed horizontally.

Remove the bolt (1) with a Phillips screwdriver and remove the upper cover(2), the cover plate(3), and the seal gasket (7). Add DOT4 brake fluid to 3/4 of the transparent observation window of the front disc brake master pump.

Be sure to clean the foreign body before reassembling it.

Fig.6 FRONT FORK COMPONENT		Add brake fluid, rocker adjustment	CHK	⚠
			ADJ	
NO.	PART NO.	PART NAME	QTY	CAUTION
1	1134100-032000	ZT250—R Right Hand Rocker (Machine)	1	
2	1100300-044000	Front brake main pump component (without handle)	1	
3	1251513-013000	Disc brake copper washer $\phi 15 \times \phi 10.2 \times 1.5$	2	
4	1251100-112000	Disc brake oil pipe bolt M10×1—22	1	32N.m

CAUTION:

- The motorcycle should be fixed after horizontal support and check.
- Periodically check that the fluid level of the brake fluid is at 3/4 of the observation window.
- If the liquid level is under "LOWER", check the brake disc wear and brake system for leaks.
- If you swallow the brake fluid, contact poison control center or hospital immediately; if you get into your eyes, seek medical attention immediately after flushing with clean water.
- Keep brake fluid away from children and pets.
- Do not flush the cup directly with high-pressure water.
- Do not mix water, dust, impurities, and silicic acid or petroleum-based liquids, as this may cause serious damage to the brake system.

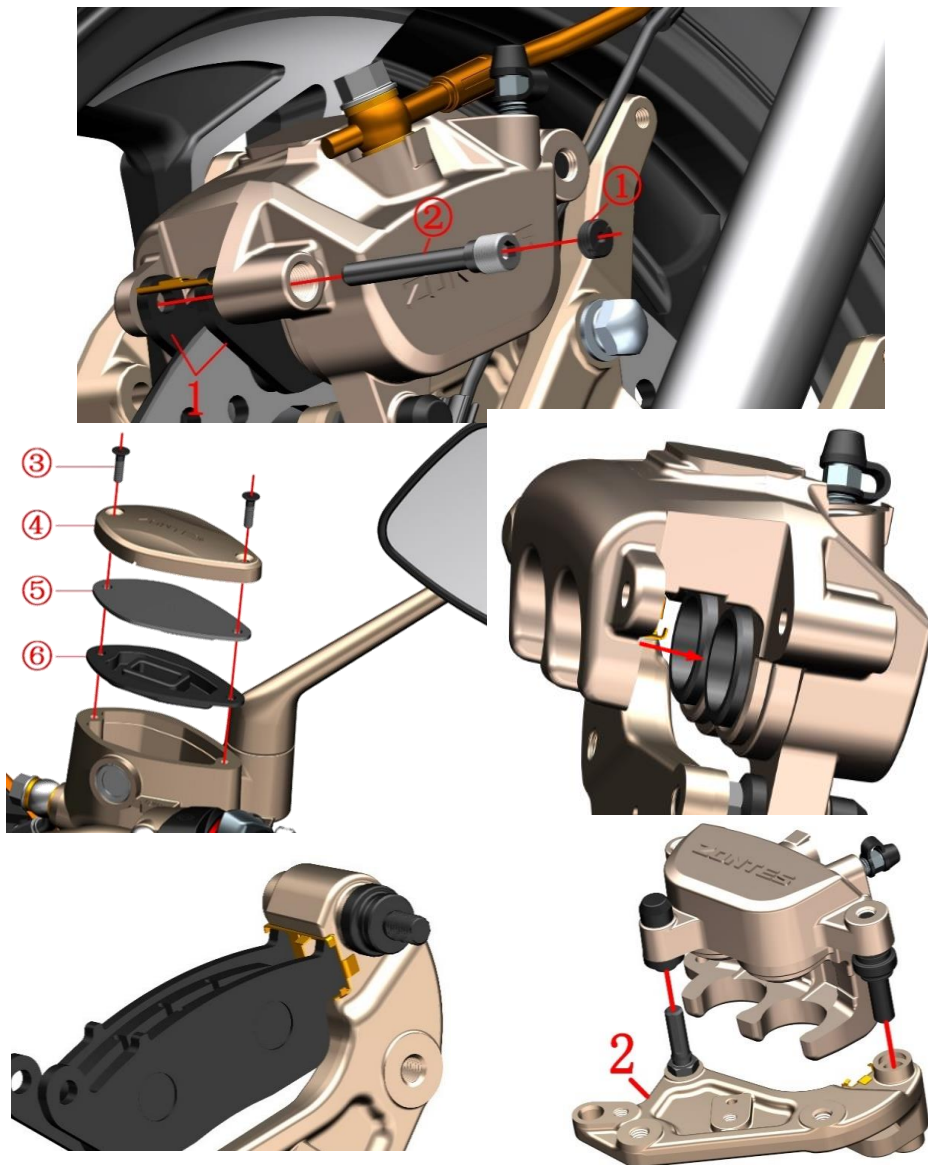

Fig.7 FRONT FORK COMPONENT		Replace the front brake pad		CHK	
				ADJ	
NO.	PART NO.	PART NAME		QTY	CAUTION
1	1100100-091000	ZT250—S Front disc brake pad (H10)		1	after-sales
2	1100100-570000	ZT310—T front brake caliper mounting plate		1	after-sales

PROCEDURE:

● Replace the front brake pad

Use a screwdriver to remove the nut ①.

Remove pin ② with hexagon tool.

Remove the brake pad (1).

Clean out foreign matter such as dust on the outer edge of the piston.

Use a Phillips screwdriver to remove the bolt ③ on the front brake main pump assembly, remove the top cover ④, cover plate ⑤, and seal gasket ⑥.

Push the piston in the direction of the arrow.

Restore the front disc brake main pump assembly, it must be accurately assembled in place.

Put a new brake pad, be sure to place the brake pad close to the card slot, as shown on the left.

Lock the pin ② with the Allen tool.

Use a flathead screwdriver to lock the nut ①.

Repeatedly holding the brake handle until braking force is restored.

● Front brake caliper mounting plate

Remove the mounting plate (2) from the caliper. Be careful not to lose the shrapnel of the front brake caliper.

CAUTION:

● The motorcycle support should be fixed before operation.

● Check the brake discs and brake discs regularly for wear. Regularly check if the brake fluid level in the observation window of the front disc brake master pump is 3/4.

● It is strictly prohibited to disassemble the oil pipe bolts and gas discharge nozzle bolts when replacing the brake pads to prevent air from entering the pipeline and causing brake failure.

● Do not shake the front after disassembling the front brake oil cup cover to prevent the brake fluid from overflowing.

● After replacing the brake pads, the new brake pads should be operated for about 300 km to fully run in order to achieve the best braking effect. Take care to leave enough braking distance during running-in.

● It is recommended to replace brake pads in pairs with qualified maintenance units.

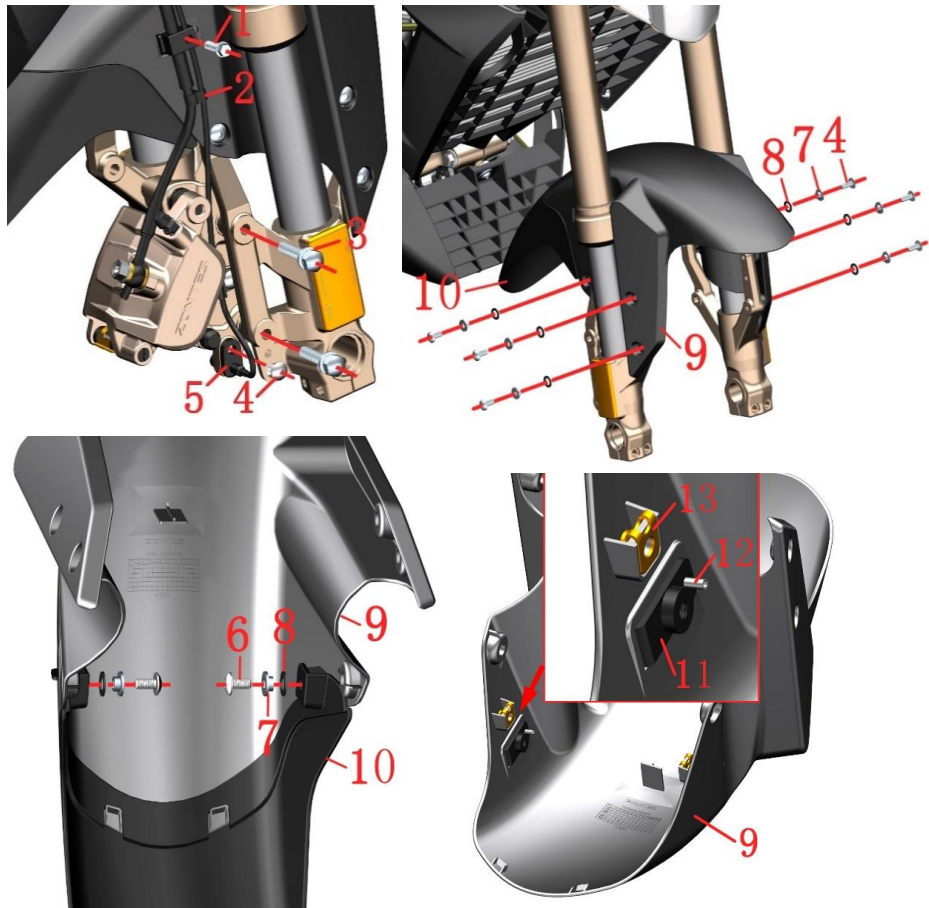
**CAUTION:**

- Pay attention to the strength when disassembling the front mud plate to prevent scratching the paint surface.
- The front fender assembly already includes a tapping tube mount (11) and a rivet (12). Rivets need to be assembled with professional tool.

Fig.9 FRONT FORK COMPONENT		Front mudguard & wheel speed sensor component	CHK	⚠
			ADJ	
NO.	PART NO.	PART NAME	QTY	CAUTION
1	1251100-061093	M6×22 Hex flange face full thread bolt	1	
2	1224100-044000	Wheel speed sensor clamp	3	
3	1251100-080094	Non—standard bolt M8×37 (color zinc)	2	
4	1251100-102000	Non—standard bolt M6×16 (304 stainless steel)	7	
5	1181200-118000	Wheel speed sensor(A)	1	
6	1251100-101000	Non—standard bolt M6×12 (304 stainless steel)	2	
7	1274100-155095	Flanged bushing φ6.2×φ8.4×3.5+φ14×1.5(5 pcs/after-	8	
8	1241200-124021	flanging bushing buffer rubber (φ8.5×φ14×1)(5 pcs/aft	8	
9	4044201-393051	ZT310—V front fender assemblight graylight graybly (dark light gray /titanium gold decal/ ABS)	1	black
	4044201-395051	ZT310—V front fender assembly (dark light gray/ red decal/ABS)		red
	4044201-396051	ZT310—V front fender part assembly (dark light gray / yellow decal / ABS)		yellow
	4044201-394051	ZT310—V front fender assembly (dark light gray/purple decal / ABS)		purple
	4044201-397051	ZT310—V front fender assembly (dark Light Gray /white decal / ABS)		white
10	1224200-107000	ZT310—V front fender extension baffle	1	
11	1274200-038000	ZT310—X Front mudguard front oil pipe fixing seat	1	after-sales
12	1250402-001091	GB12615φ3×10	1	
13	1251300-063093	plywood M6×11×15 (color zinc)	2	

PROCEDURE:

- Wheel speed sensor
Pull out the plug of the wheel speed sensor(5); then remove the clamp(2). Remove the bolt(4) then remove the sensor(5).
- Front disc brake caliper
Remove the bolts(1) and (3) so that the caliper will hang down naturally. It is forbidden to invert the caliper to prevent the air from entering and causing the brake to fail.
- Front mudguard
Remove the 6 bolts (4) with the hexagonal tool by hand and remove the bushing (7) and cushion rubber (8).
Flip to the back, remove the two bolts (6), and remove the bushing (7) and cushion rubber (8). Separate the front fender (9) from the extended baffle (10) .
Remove the two splint nuts (13) from the front fender (9)
The inside of the front mudguard can be protected with reticle or double-sided tape around the rivet (12), then the rivet is ground off with a small sander, and the fixing seat (11) are removed.



Fig.10 FRONT FORK COMPONENT		Headlights assembly 1	CHK	
NO.	PART NO.	PART NAME	ADJ	
1	1250205-040095	GB70.1 inner hex bolt M8×16 (color Zinc)	2	CAUTION
2	1250501-007093	GB93φ8(color zinc)	2	
3	1224200-008000	ZT310—R line card nail	4	
4	1226000-218000	Grade 0 flame retardant tie (black 3.6×295)(5 pcs/after-	2	
5	1251100-102000	Non—standard bolt M6×16 (304 stainless steel)	2	

PROCEDURE:

● Headlights assembly

Refer to the steps of the front light adjustment to remove the decorative cover on the headlights and turn the turn signal assembly up.

Remove the bolts (1) on both sides with a 6# hexagon socket and remove the spring washer (2).

Turn the headlight assembly in the direction of the arrow; expose all cable connectors.

Cut two tie straps (4).

Pull the wire clip (3) from the back of the storage box with a pointed tip and pull it out of the storage box.

First pull out the turn signal line head (5).

Then separate all the plugs from the main cable and arrange all the cables.

Remove the line plug from the back of the 4 plugs, ① headlight, ② right hand switch, ③ faucet lock switch, and ④ left hand switch (3).

● Turn signal assembly

Remove the bolts (5) after grasping the left and right turn signal assemblies and remove them.

CAUTION:

- Pay attention to the strength when removing the line plug.
- Pay attention to all cables in the original wiring when reassembling.

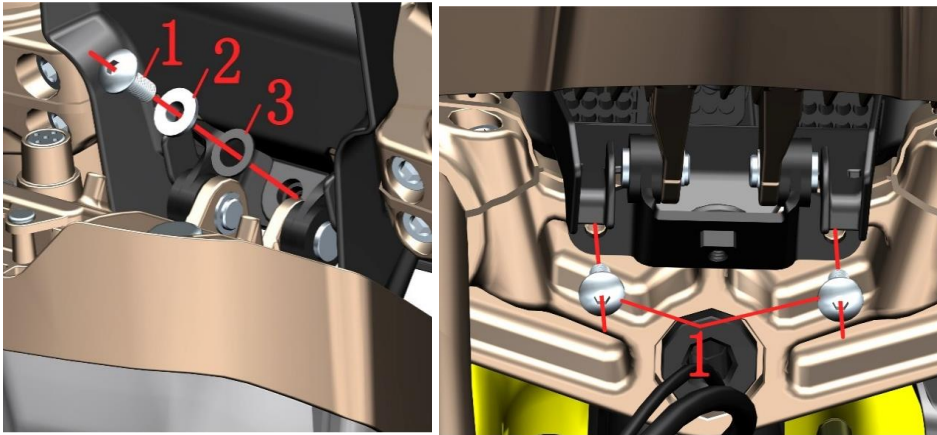

Fig.11 FRONT FORK COMPONENT		Headlights assembly 2	CHK	⚠
			ADJ	
NO.	PART NO.	PART NAME	QTY	CAUTION
1	1251100-102000	non-standard bolt M6×16 (304 stainless steel)	3	
2	1274100-155095	Flanged bushing φ6.2×φ8.4×3.5+φ14×1.5(5 pcs/after-	1	
3	1241200-124021	flanging bushing buffer rubber (φ8.5×φ14×1)(5 pcs/af	1	
4	1174300-002051	ZT350-V-A1 front combination headlight(titanium)	1	
5	1274200-133000	ZT310-V headlight lower bracket	1	
6	1240400-007000	battery holder buffer aprons	2	
7	1264100-006000	ZT250-S Pedal circlip	2	
8	1274200-024000	ZT310-R Front light rotated pin	2	

PROCEDURE:

● Headlight assembly

Turn the headlight assembly forward to expose the bolt at the bottom of the storage box, remove the bolt (1), and remove the bushing (2) and cushion rubber (3).

Turn the headlight up and remove the two bolts (1) at the bottom of the lower plate.

Remove the headlight assembly.

Remove the two pin shanks (7) and remove the two pins (8).

Separate the headlights (4) from the bracket assembly.

Remove two pieces of cushion rubber (6) from the bracket (5).

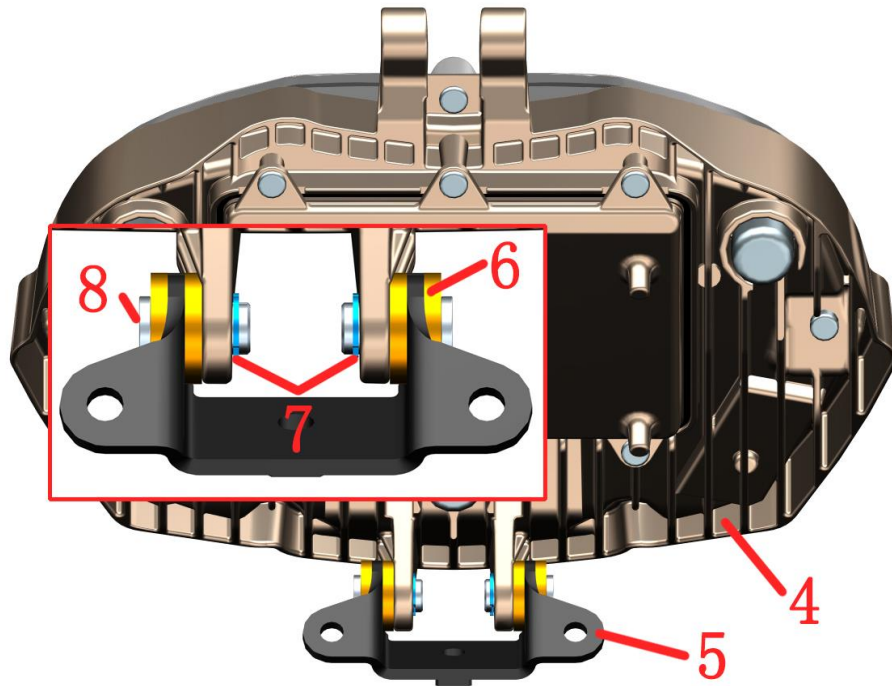

CAUTION:

● Protect protective measures to prevent scratching the lampshade or paint finish.

● The headlights use imported LED light sources. It is recommended not to change the internal structure of the headlights. It is forbidden to destroy the sealing structure of the headlights, prevent water mist from forming inside the lamps and affect driving safety.

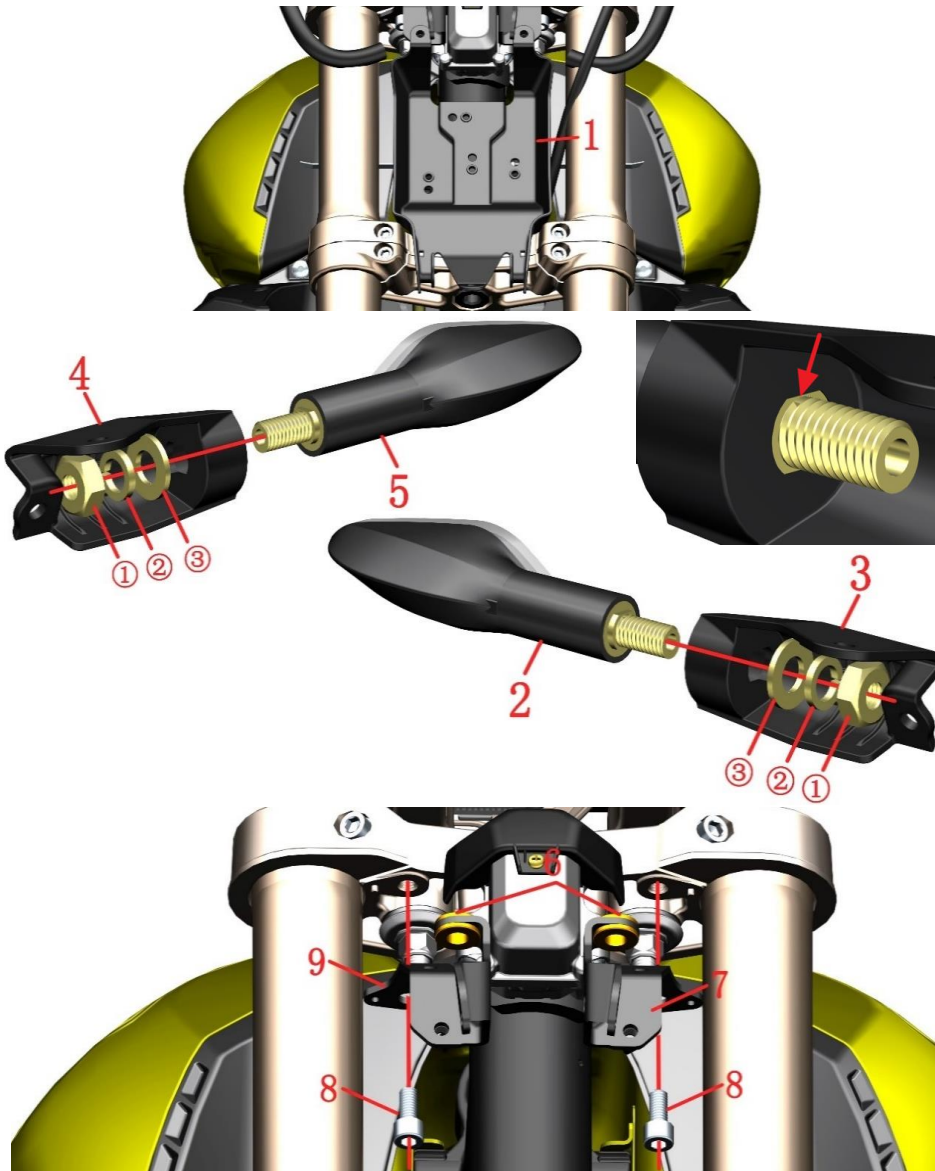

Fig.12 FRONT FORK COMPONENT		Headlights assembly 3	CHK	
NO.	PART NO.		PART NAME	
1	1224200-121000	ZT310 -V storage box	1	
2	1170300-063000	front left turn signal light	1	
3	1224200-122000	ZT310-V front turn signal left bracket	1	
4	1224200-123000	ZT310-V front turn signal right bracket	1	
5	1170300-064000	front right turn signal light	1	
6	1244100-137000	ZT250-S Flanging bushing buffer(5 pcs/after-sale)	2	
7	1274200-132000	ZT310-V headlamp left bracket	1	
8	1250205-040095	GB70.1 inner hex bolt M8×16 (color Zinc)	2	
9	1274200-134000	ZT310-V headlamp right bracket	1	

● Storage box

Remove all the cables and remove the cable box (1)

● Turn signal assembly

Turn the turn signal assembly to the back, use the open-end wrench to remove the nut ① that comes with the turn signal, and remove the spring pad ② and the gasket ③. Separate the turn signal from the bracket.

● Headlight bracket

Remove 2 pieces of cushion rubber (6)

Grab the left bracket (7) or the right bracket (9) and remove the bolt (8)

CAUTION:

● When reassembling, check if there is any pressure on the wire to prevent it from tightening Short circuit caused by bolts. Pay attention to the lamp connector, do not insert the wrong, turn left Green + orange; right turn signal is green + blue.

● Note that the positioning boss on the turn signal corresponds to the slot on the bracket

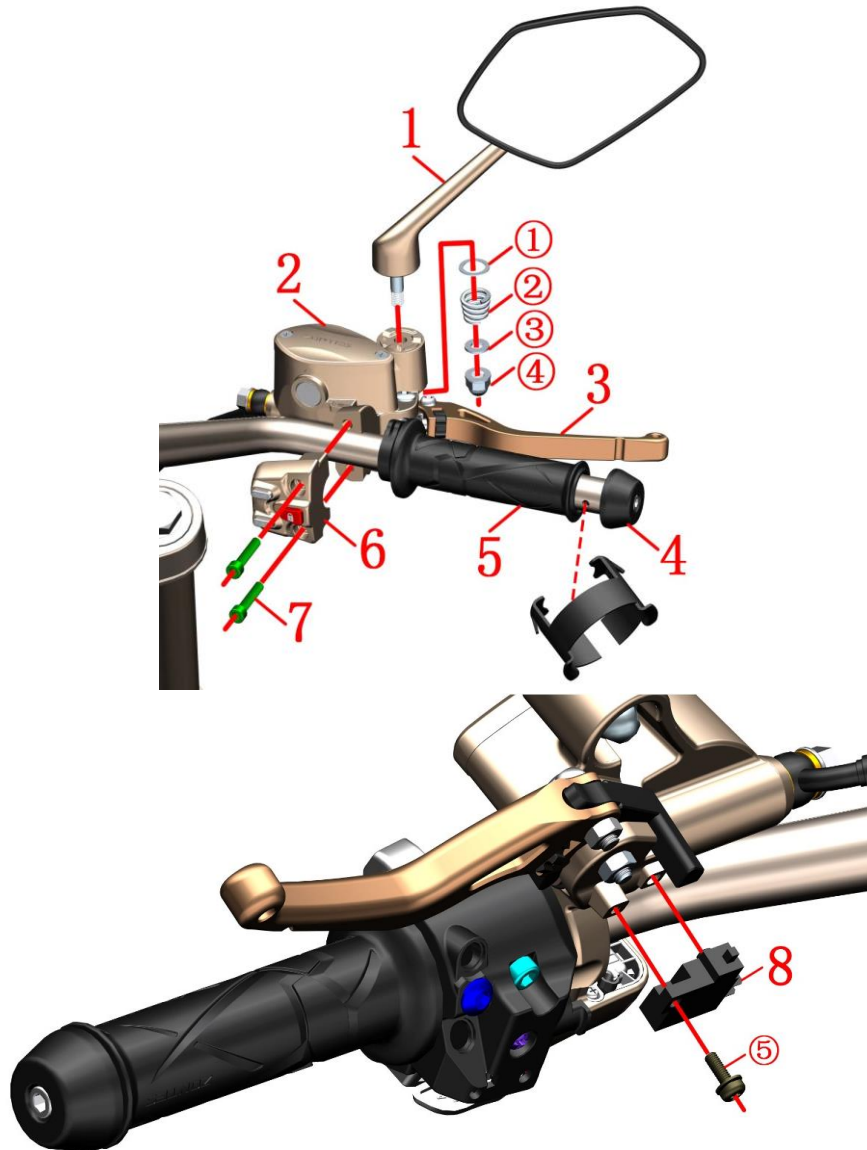

Fig.13 FRONT FORK COMPONENT		Right handlebar component	CHK	⚠
			ADJ	
NO.	PART NO.	PART NAME	QTY	CAUTION
1	1194100-002000	ZT250—S Right rearview mirror	1	
2	1100300-044000	Front disc brake main pump component (without handle)	1	
3	1134100-032000	ZT250—R Right Hand Rocker (Machine)	1	
4	1134200-023000	ZT250—R Balancing block	1	
5	1244100-140000	ZT250-R right handle bar rubber sleeve(after-sale)	1	
6		Right handlebar switch	1	
7	1250205-031091	GB70.1M6×30 (stainless steel)	2	
8	1100100-583000	ZT125T front brake switch	1	after sale

PROCEDURE:

●Rearview mirror

Hold the mirror stem in one hand, remove the nut ④ with a sleeve, and remove the small pad ③, the spring ② and the large pad ①. Remove the mirror from the front brake master pump.

●Right handlebar to put rubber sleeve, balance block

Push the rubber sleeve (5) with the right handlebar to push forward to expose the upper balance block fixing hole; use the tool to press the convex parts at both ends of the elastic block on the balance block and pull out the balance block assembly (4), and then put the right handlebar. Remove the rubber sleeve (5).

●Right handlebar half cover

Hold the front disc brake main pump (2) with one hand, and remove the bolt (7) with the hexagon socket tool. Remove the wire plug connector of the sub switch (6) and pull it out.

●Front brake switch replacement

Unplug the brake switch

Remove the bolt ⑤ attached to the front brake main pump and replace the front brake switch. Note that the boss on the brake switch is aligned with the limit hole at the arrow indication of the front brake main pump.

CAUTION:

- The motorcycle should be fixed after horizontal support.
- Periodically check that the fluid level of the brake fluid is between 3/4 of the observation window.
- Do not flush the cup directly with high pressure water.
- When assembling the balance block, align the protruding parts at both ends of the shrapnel with the fixing holes on the handle and then insert the direction into the holes.
- The small spacer of the rear view mirror anti-rotation limit slot needs to be aligned with the slot on the mirror bar bolt.
- The right handlebar refers to the switch to replace the throttle line.
- The joint between the front disc brake main pump and the half cover should be aligned with the right hand to match the triangle on the switch.
- The old model will be discontinued; the old switch can be replaced directly with the new one.

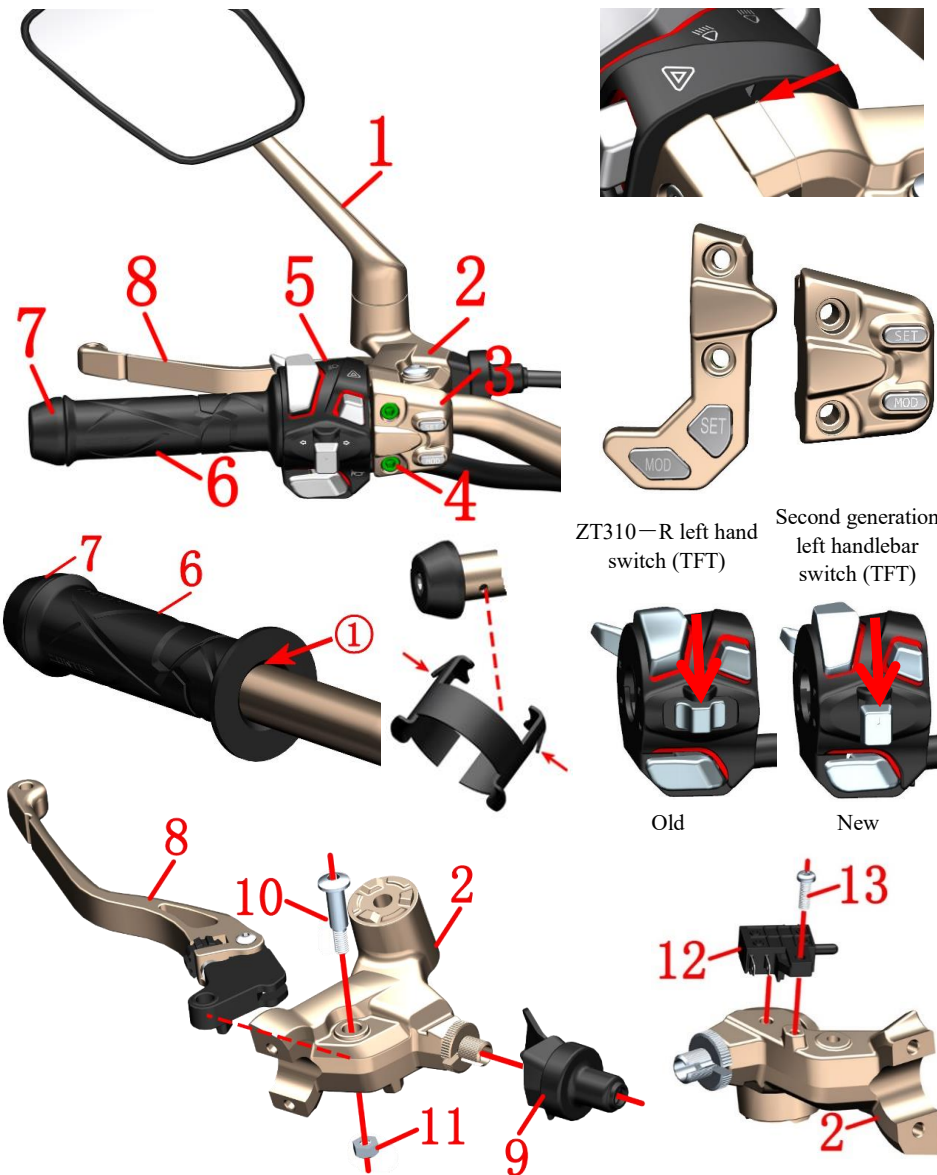

Fig.14 FRONT FORK COMPONENT		Left hand component	CHK	CAUTION
NO.	PART NO.	PART NAME	ADJ	
1	1194100-001000	ZT250—S left rear view mirror	1	
2	1134200-011000	ZT310—V left hand rocker arm component	1	
3		Left hand switch	1	
4	1250205-031091	GB70.1M6×30 (stainless steel)	2	
5		Left handlebar switch	1	
6	1244100-139000	ZT250-R left hand rubber sleeve(after-sale)	1	
7	1134200-023000	ZT250—R balance block	1	
8	1134200-010000	ZT310—V left hand rocker arm (machine plus)	1	
9	1244200-046000	ZT310—V protective rubber sleeve	1	
10	1251100-198000	Non—standard bolt M6×13—φ8×20	1	
11	1251300-073000	GB/T6185 nut M6	1	
12	1184200-170000	ZT310—V clutch switch	1	
13	1250201-039000	GB818 cross recessed pan head screw M4×12 (color zinc)	1	

PROCEDURE:

- left rear view mirror, left switch, rocker arm

Remove the clutch line by referring to the "Replace Clutch Line" procedure. Remove the left rear view mirror (1), rocker base(2), left sub switch(3), bolt(4), left switch(5), and rocker arm(8) by referring to the steps in "Right Handle Assembly" and "Add Brake Fluid, Adjusting Rocker Arm".

- Left hand rubber sleeve and balance block assembly

Use a blow gun to blow the left hand grip between the rubber sleeve(6) and the direction handle tube while moving the rubber sleeve inward until the balance block positioning hole is exposed. Use the tool to press the convex part at both ends of the elastic piece on the balance block and pull out the balance block assembly(7). Use a blow gun and move the outer sleeve to remove the left hand grip(6).

- Replace the left hand rocker arm and clutch switch

Fix the bolt(10) with a hexagonal tool, then remove the nut(11) with a sleeve or a wrench, remove the bolt(10) and then remove the left hand rocker arm(8). First unplug the clutch switch, then remove the bolt(13) with a Phillips screwdriver and remove the clutch switch(12). The rotation adjustment nut can adjust the distance between the rocker arm and the left hand rubber sleeve to adapt to the feel of different drivers.

CAUTION:

- In mid-July 2019, the old hand switch was switched to the new one. The old model will be discontinued; the old switch can be replaced directly with the new one.
- Press during reassembly: the left hand grip rubber sleeve - balance block - switch - left hand rocker arm - left rear view mirror. Note the triangle symbol on the rocker arm assembly and the half cover seam alignment switch.

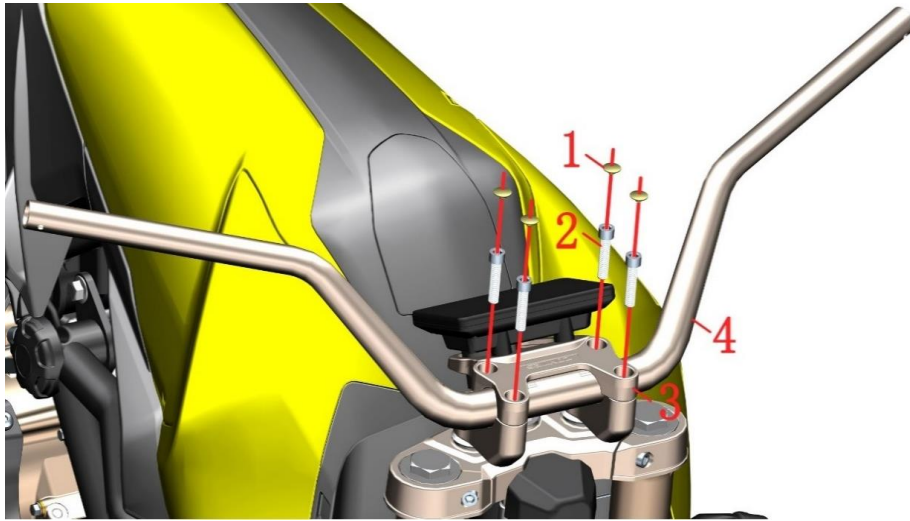

Fig.15 FRONT FORK COMPONENT		Direction handle&TFT Instrument	CHK	
			ADJ	
NO.	PART NO.	PART NAME	QTY	CAUTION
1	1224100-094051	ZT250-S M8 bolt decorative buckle (titanium gold/WX)	4	
2	1250205-034093	GB70.1 Hexagon M8×30 (color zinc)	4	
3	1032142-062051	ZT310-V direction clamp	1	
4		Direction	1	
5	1250301-049093	GB6170M6 (environmental color)(5 pcs/after-sale)	3	8~12N.m
6	1250502-010093	GB96.1φ6 (environmental color)	3	
7	1244200-203000	ZT310TFT Instrument Buffering Gasket (5 pieces / after-sale)	3	
8		TFT instrument	1	

PROCEDURE:

● Directional components

The instrument connector above the upper plate nut presses the limit buckle at the arrow indication and unplugs the connector in the direction of the upper plate.

Use a blade to pick up the decorative buckle (1), hold the direction handle (4) in one hand, and remove the bolt (2) with a hexagonal tool in one hand; remove the clamp (3) and finally remove the direction handle (4).

● Instrumentation components

Flip the instrumentation component remove the nut (5) by turning the meter and clamp assembly to the back, remove the gasket (6), and remove the meter (8). Take care to protect the meter screen.

Remove the cushion rubber (7) from the direction of the clamp (3).

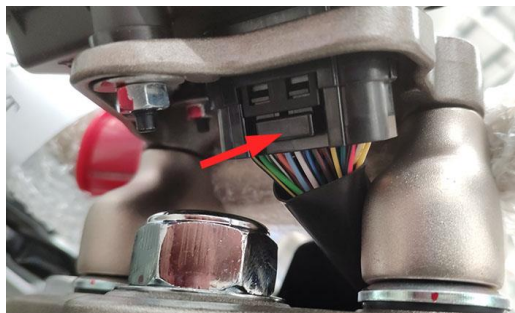

40T



60T

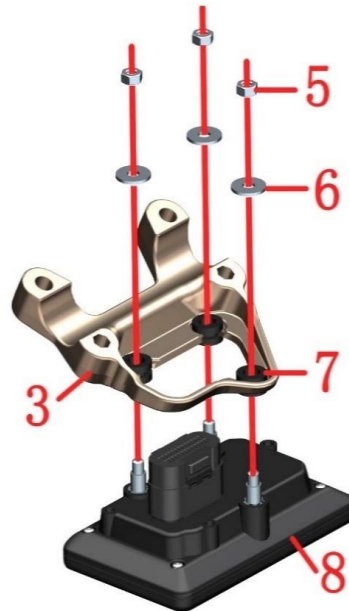

CAUTION:

- Protect protective measures to prevent scratching the appearance of the instrument case and the decorative cover
- Pay attention to the strength when opening the decorative cover clip to prevent the staple from breaking due to excessive force.
- The vehicle produced before May 18, 2019 is a 40-tooth induction ring gear; after May 18, 2019, it is 60 teeth. The two cannot be mixed.
- The meter needs to correspond to the ring gear. Misplacement will result in inaccurate speed display. The 60-ring ring has a "60" printed on the back of the meter.

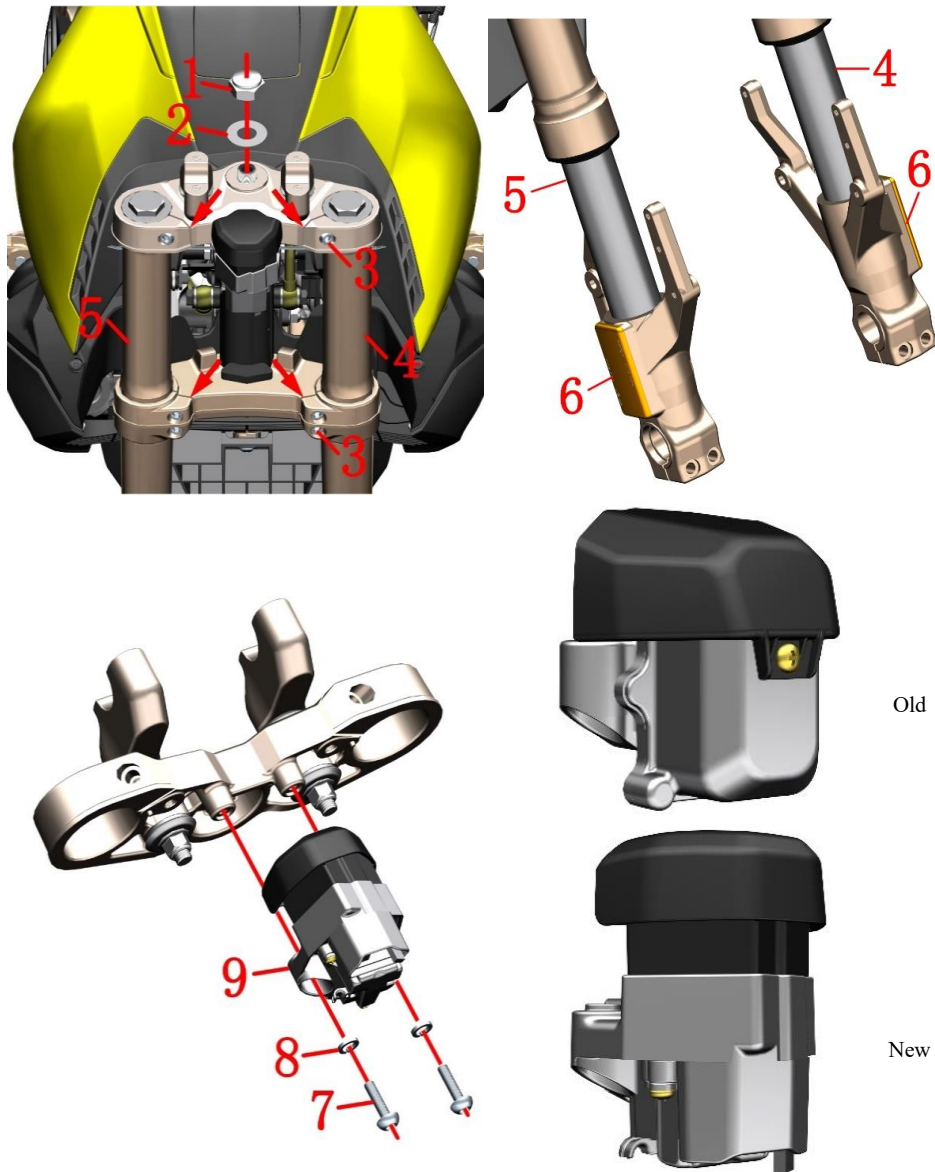

Fig.16 FRONT FORK COMPONENT		Front shock absorber, upper plate component	CHK	⚠
			ADJ	
NO.	PART NO.	PART NAME	QTY	CAUTION
1	1251300-045000	ZT250—S upper plate decorative nut (chrome plated)	1	
2	1251500-050000	ZT250—S upper plate gasket φ18.5×φ39×1	1	
3	1250205-034093	GB70.1 Hexagon M8×30 (color zinc)	6	25N.m
4		ZT310—V front left shock absorption(improve)	1	Includede reflective sheet
5		ZT310—V front right shock absorption(improve)	1	
6	1174100-001000	Reflection light (KM115)	2	after-sales
7	1251100-364000	Non-standard bolt M6×25(color/10.9 grade)	2	
8	1250501-007093	GB93φ8 (environmental color zinc)	2	
9	1184200-034000	ZT310—R electronic faucet lock (DC)	1	old,stop sale
	1184200-139000	ZT310 faucet lock (electromagnetic drive / line length 150) assembly		

PROCEDURE:

●Uplink board assembly

Locate the faucet lock plug and remove it; remove the nut(1) and the shims(2). Remove the upper plate bolt(3).

●Front left and right shock absorption

Remove the bolts(3) of the lower plate, and hold the shock absorber in the middle with one hand. Insert a slotted screwdriver into the slot of the upper and lower plates to slightly enlarge the slot clearance, and disassemble the left shock absorber (4) and the right shock absorber(5). under. Remove the upper plate assembly.

Old

●Reflecting film

Reflective sheets are sold separately for sale (no replacement shock absorption). The heat-reflecting sheet can be moved back and forth by a hot air blower to reduce the viscosity of the double-sided adhesive after being heated, and the residual glue should be cleaned after removing the reflector.

●faucet lock

Remove the bolt (7) and the spring washer(8) and the faucet lock(9). Old faucet lock can be replaced as new models.

CAUTION:

●Use a flat-blade screwdriver to enlarge the gap between the upper and lower joint plates without applying excessive force to avoid damage.

New

●The old faucet lock can be purchased directly for a new replacement.

● Switch to improved from June 4,2021.Older models requires two shocks switch to an improved version.

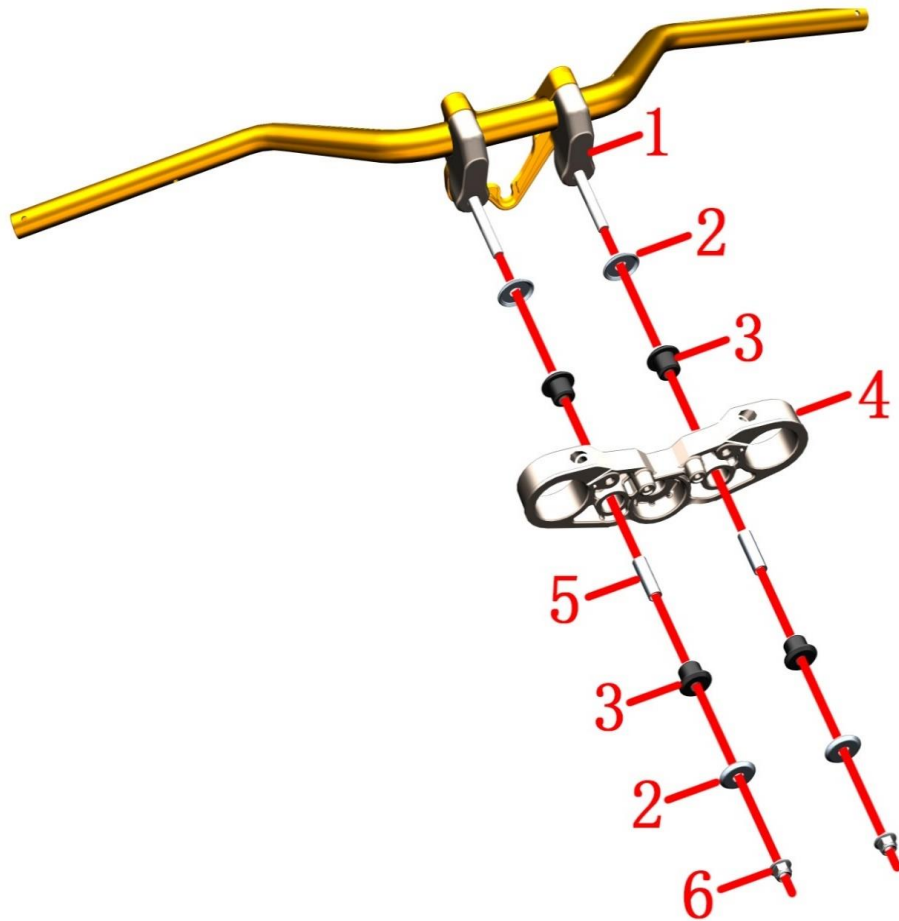

Fig.17 FRONT FORK COMPONENT		Uplink plate, direction handle block component		CHK	
				ADJ	
NO.	PART NO.	PART NAME		QTY	CAUTION
1	1134200-019000	ZT310-V direction pad assembly		2	
2	1274200-018000	ZT310-R upper plate gasket		4	
3	1244200-008000	ZT310-R upper plate buffer rubber		4	
4	1134200-004000	ZT310-R upper plate		1	
5	1251700-065000	ZT310-R bushing $\phi 10 \times \phi 12 \times 41$		2	
6	1251300-057093	Non-standard nut M10×1.5 (Dacro)		2	40N.m

PROCEDURE:

● Uplink plate and spacer assembly

In order to facilitate the direction of the block, the direction and the upper block should be assembled first to prevent the block from rotating during the disassembly process. The direction should be wrapped with cotton or other soft materials to prevent scratching the paint surface.

Remove the nut(6) and remove the gasket(2), cushioning rubber(3), and bushing(5). Remove the upper plate(4).

The spacer(1), the upper clamp and the direction handle are disassembled.

CAUTION:

● Protect protective measures to prevent scratching the appearance of parts.

● When reassembling, it is necessary to use the direction to ensure that the center and direction of the spacers on both sides are coaxial with the center. First install 4 pieces of cushioning rubber into the upper plate and then install the bushing separately. Make sure that the bushing is flush with the cushioning rubber, otherwise it should be reassembled. When tightening the nut, ensure that the torque is 40N.m. Check the buffer for spillage and reassemble if necessary.

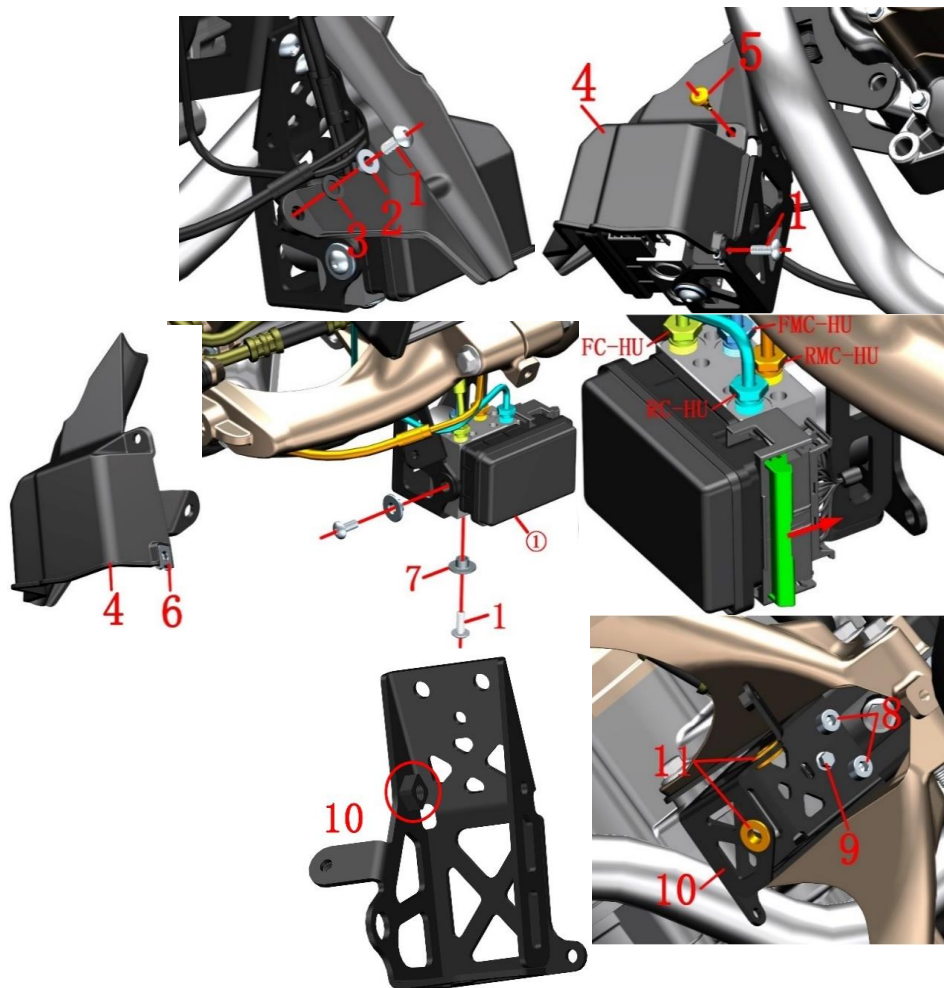

Fig.18 FRONT FORK COMPONENT		ABS brake system—1	CHK	⚠
			ADJ	
NO.	PART NO.	PART NAME	QTY	CAUTION
1	1251100-102000	Non—standard bolt M6×16 (304 stainless steel)	4	
2	1274100-155095	Flanged bushing φ6.2×φ8.4×3.5+φ14×1.5(5 pcs/after-	1	
3	1241200-124021	flanging bushing buffer rubber (φ8.5×φ14×1)(5 pcs/af	1	
4	1224200-140000	ZT310—V hydraulic control unit protective cover	1	
5	1224100-089000	ZT250-S Expansion nail(5 pcs/after-sale)	1	
6	1251300-063093	plywood M6×11×15 (color zinc)	1	
7	1274101-015000	ZT250-S flanging sleeve(φ6.4×φ9×6+φ20×2)(5 pcs/af	2	
8	1250205-040095	GB70.1 inner hexagonal M8X16 (color zinc)	2	
9	1251112-001093	M6×16 Hexagon flange bolts (color zinc)	1	
10	1274200-192000	ZT310—V hydraulic control unit mounting bracket	1	
11	1244100-137000	ZT250-S Flanging bushing buffer(5 pcs/after-sale)	2	

PROCEDURE:

●Hydraulic control unit cover

Remove the bolt (1) on the right side, remove the bushing (2) and the cushion rubber (3). Remove the expansion screw on the left side (5). Remove the bolt (1) and remove the protective cover assembly. Remove the splint nut (6) from the protective cover (4).

●Hydraulic control unit

Push the cable connector push rod in the direction of the arrow on the left side to unplug the connector. Remove the two bolts (1) and remove the bushing (7).

●Brake fluid

Refer to the previous step of adding brake fluid to remove the upper cover, cover and sealing gasket of the front and rear disc brake main oil cups. Place the oil pan underneath. After wearing the waterproof gloves, pull out the hydraulic control unit and tilt it to the right side. Use an open-end wrench to loosen the nut joints of the four oil pipes. After the brake fluid is discharged, remove the hydraulic control unit and wipe off the oil. Be careful not to let the brake fluid come into contact with the cable connector to prevent poor contact due to corrosion. RC-HU is connected to the hydraulic control unit and rear brake caliper; RMC-HU is the rear disc brake main pump; FC-HU is the front disc brake caliper; FMC-HU is the front disc brake main pump.

●Hydraulic control unit bracket

Remove 2 pieces of cushion rubber (11) from the bracket (10).
Remove the hydraulic control unit bracket (10) after removing the bolts (8) and (9).

CAUTION:

- Be sure to disassemble the muffler and engine after they have cooled down completely. The horizontal support of the vehicle should be fixed before disassembly and assembly work.
- The precautions for brake fluid are described in the previous section.
- The torque of the four tubing nut joints of the hydraulic control unit is 18N.m
- Starting from September 1, 2020, the ZT310-V hydraulic control unit mounting bracket will add an M8 spot welding nut as shown in the figure.

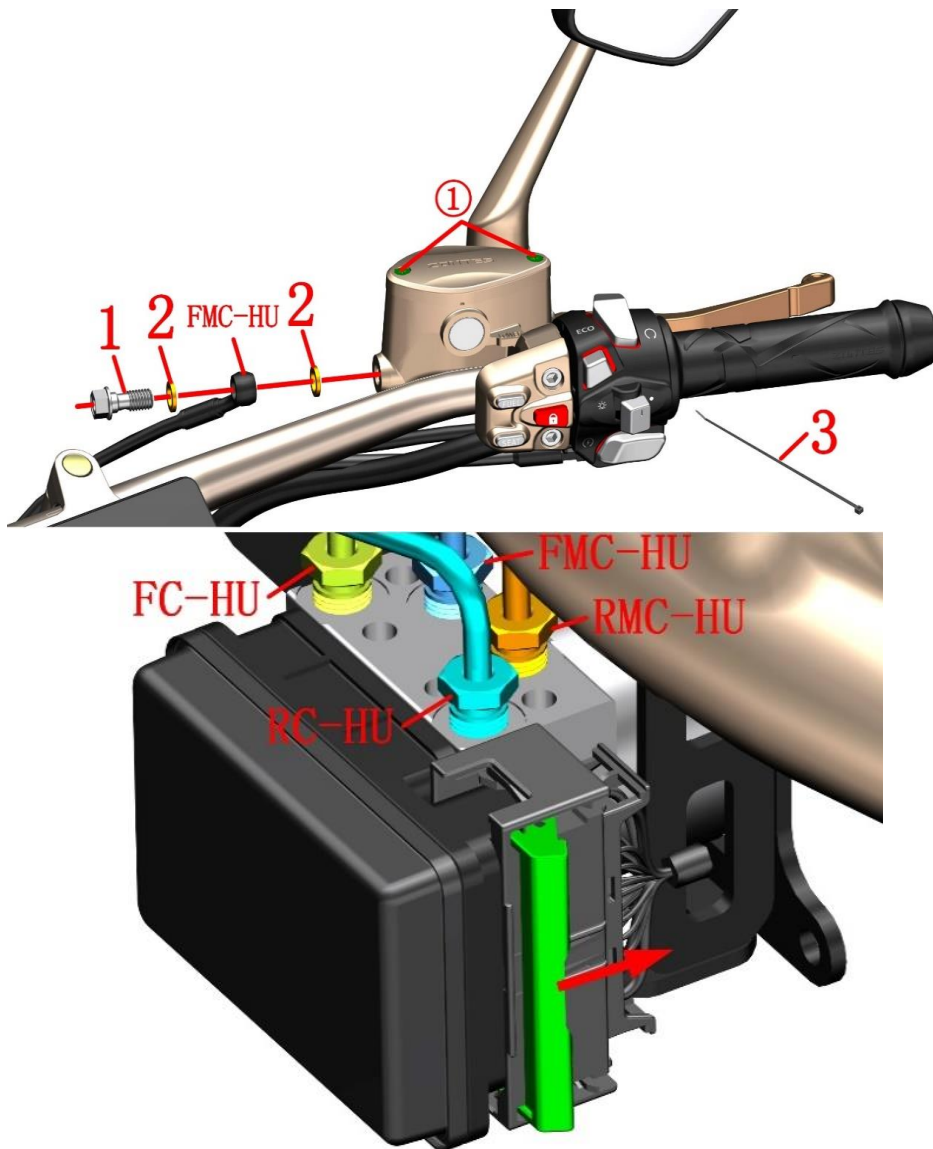

Fig.19FRONT FORK COMPONENT		ABS brake system—2		CHK	
NO.	PART NO.	PART NAME	QTY	ADJ	
1	1251100-112000	Disc brake tubing bolt M10×1—22	1		32N.m
2	1251513-013000	Brake brake tubing copper washer φ15×φ10.2×1.5	2		
3	1226000-218000	Grade 0 flame retardant tie (black 3.6×295)(5 pcs/after-	3		

PROCEDURE:

● Front disc brake main pump

Cut three straps (3)

Place the oil pan under the hydraulic control unit.

In the previous step of the parameter, remove the hydraulic control unit cover and the brake fluid step to connect the FMC-HU tubing to the hydraulic control unit.

After wearing the waterproof gloves, remove the bolts (1) with a 12# sleeve; remove the copper washers (2). Remove the FMC-HU tubing. It is recommended to replace the two copper washers (2) at the same time when replacing the tubing. The bolts (1) can be replaced if they are not damaged.

Wipe the end faces of the bolt (1) and the front disc brake main pump before replacing the FMC-HU tubing. After installing the tubing, add DOT4 brake fluid and vent the brake system. Detailed steps can be found in Adding Brake Fluid.

CAUTION:

● Be sure to disassemble the muffler and engine after they have cooled down completely. The horizontal support of the vehicle should be fixed before disassembly and assembly work.

● The precautions for brake fluid are described in the previous section.

● The torque standard of the four tubing nut joints at the pilot unit is 18N.m

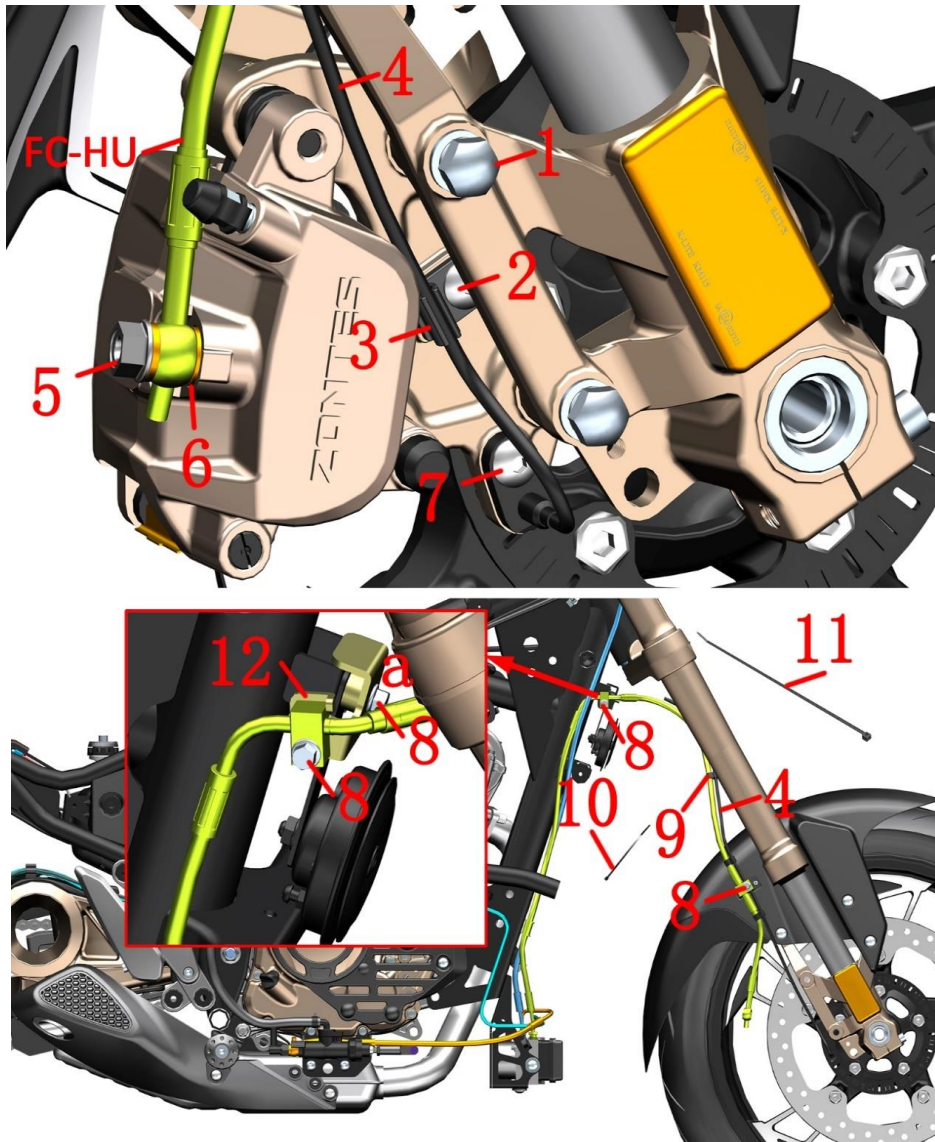

Fig.20FRONT FORK COMPONENT		ABS brake system—3	CHK	
			ADJ	
NO.	PART NO.	PART NAME	QTY	CAUTION
1	1251100-080094	Non—standard bolt M8×37 (environmental color zinc)	2	
2	1251100-101000	Non—standard bolt M6×12 (304 stainless steel)	1	
3	1224200-127000	ZT310—T front wheel WSS wire clip	1	
4	1181200-118000	Wheel speed sensor(A)	1	
5	1251100-112000	Disc brake tubing bolt M10×1—22	1	32N.m
6	1251513-013000	Brake brake tubing copper washer φ15×φ10.2×1.5	2	
7	1251100-102000	Non—standard bolt M6×16 (304 stainless steel)	1	
8	1251100-061093	M6×22 hex flange face full thread bolt	3	
9	1224100-044000	Wheel speed sensor clamp	3	
10	1224100-051000	0 grade flame retardant cable tie (black 2.5×100)	1	
11	1226000-218000	Grade 0 flame retardant tie (black 3.6×295)(5 pcs/after-	3	
12	1274200-033000	ZT310—R No.2 oil pipe support of front disc brake	1	

PROCEDURE:

● Brake fluid

Place the oil pan under the front disc brake caliper

After wearing the waterproof gloves, remove the bolts (5) with a 12# sleeve; remove the copper washers (6).

Remove the two bolts (1) and remove the front disc brake caliper from the front shock absorber.

First remove the wheel speed sensor (4) from the clamp (3), then remove the bolts (2) and (7), then remove the wheel speed sensor (4) and the clamp (3) from the front disc brake caliper. Organize the wheel speed sensor line neatly.

Remove the two bolts (8) on the right side.

Cut the straps (10) and (11); remove the 3 clips (9). Then remove the FC-HU tubing. If you need to replace the FC-HU tubing, it is recommended to replace the two copper washers (6) at the same time; the bolts (5) can be replaced if they are not damaged.

● Front disc brake tubing bracket

If you only need to replace the oil pipe, you do not need to remove the oil pipe bracket (11). If you need to remove it, remove the bolt (8) at the front(a) to remove the bracket.

CAUTION:

● Be sure to disassemble the muffler and engine after they have cooled down completely. The horizontal support of the vehicle should be fixed before disassembly and assembly work.

● The torque standard of the four tubing nut joints at the pilot unit is 18N.m.

● It is recommended to replace the two copper washers (6) at the same time when replacing the oil pipe. The bolts (5) can be replaced if they are not damaged.

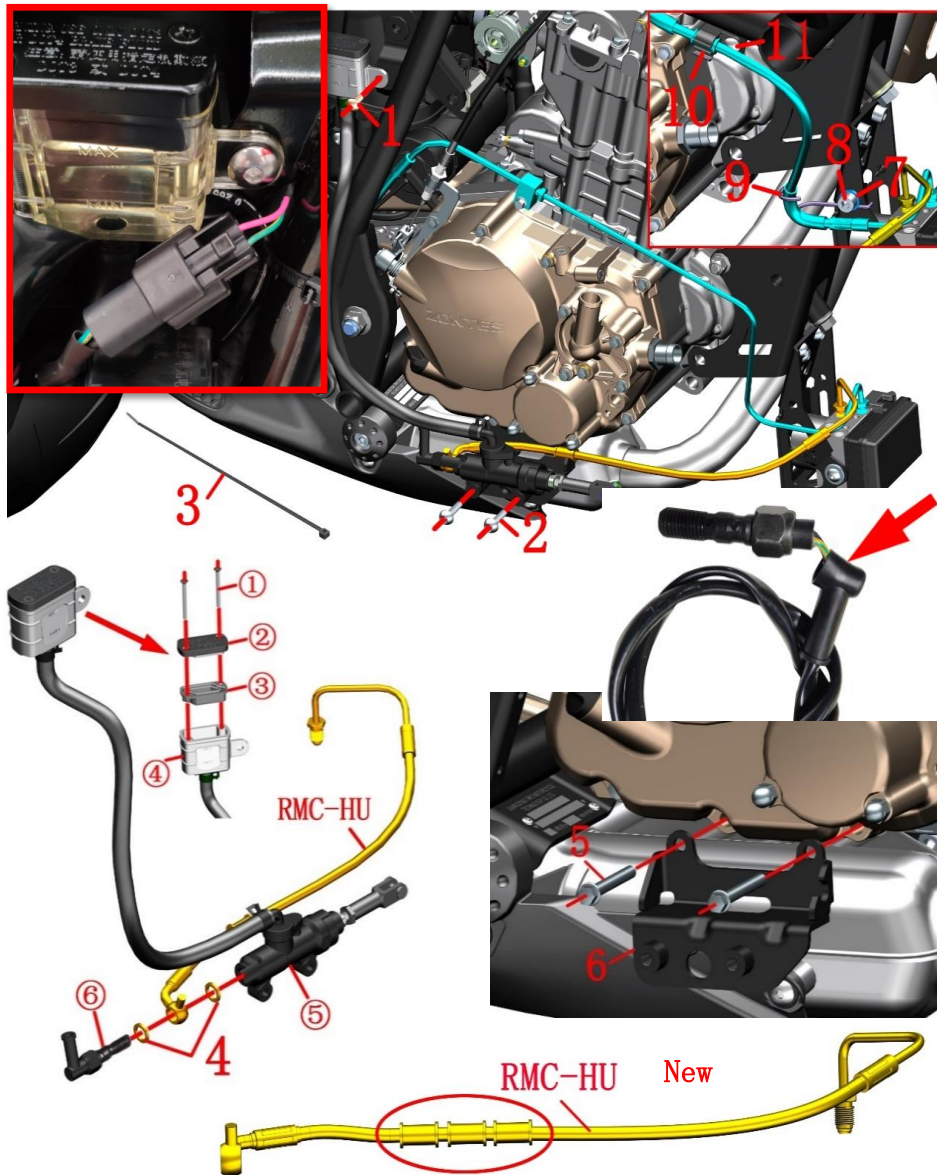

Fig.21FRONT FORK COMPONENT		ABS brake system—4	CHK	CAUTION
NO.	PART NO.	PART NAME	ADJ	
1	1251100-102000	Non—standard bolt M6×16 (304 stainless steel)	QTY	After 2021
2	1251100-364000	Non-standard bolt M6×25(color/10.9 grade)	1	
3	1226000-218000	Grade 0 flame retardant tie (black 3.6×295)(5 pcs/after-	2	
4	1251513-013000	Brake brake tubing copper washer φ15×φ10.2×1.5	1	
5	1251112-003093	M6×45 Hex flange surface 9.8 bolt (color zinc)	2	
6	1274200-246000	ZT310—V rear disc brake main pump bracket	1	
7	1250503-021093	GB97.1φ8 (environmental color)	1	
8	1250205-040095	GB70.1 inner hex bolt M8×16 (color Zinc)	1	
9	1274200-301000	ZT310-V rear disk-brake oil line hook	1	
10	1224200-003000	ZT310—R Rear disc brake pipe clamp	1	
11	1251100-101000	Non-standard bolt M6×12 (304 stainless steel)	1	

PROCEDURE:

- Brake fluid
 - Locate and drop the rear brake switch connector near the rear disc brake main pump oil cup.
 - Cut the cable tie (3). Remove the bolt (1) and the two bolts (2) and remove the rear disc brake main pump assembly.
 - Place the oil pan under the rear disc brake main pump.
 - Remove the bolt ① with a Phillips screwdriver after wear waterproof gloves.
 - Remove the oil cup cover ② and seal the rubber pad ③.
 - Pour out the brake fluid from the oil cup.
 - Use the open end wrench to remove the rear brake switch nut ⑥;remove the copper washer (3). The RMC-HU oil pipe, the rear disc brake main pump body ⑤ and the rear brake switch wire ⑥ are split.
 - Restore the rear disc brake oil cup.
 - Remove the two bolts (5) and remove the bracket (6).

CAUTION:

- It is recommended to replace the two copper washers (4) at the same time when replacing the oil pipe, rear brake switch wire or disc brake main pump.
- The rear brake switch wire is prohibited from rotating the rubber cap at the arrow indication. Replace this switch wire. Be careful not to wrap the cable around the tool.
- The torque of the four oil pipe nut joints at the pilot unit is 18 N.m.
- From September 18, 2020, two clamping sleeves have been added to the RMC-HU section of the brake hose.

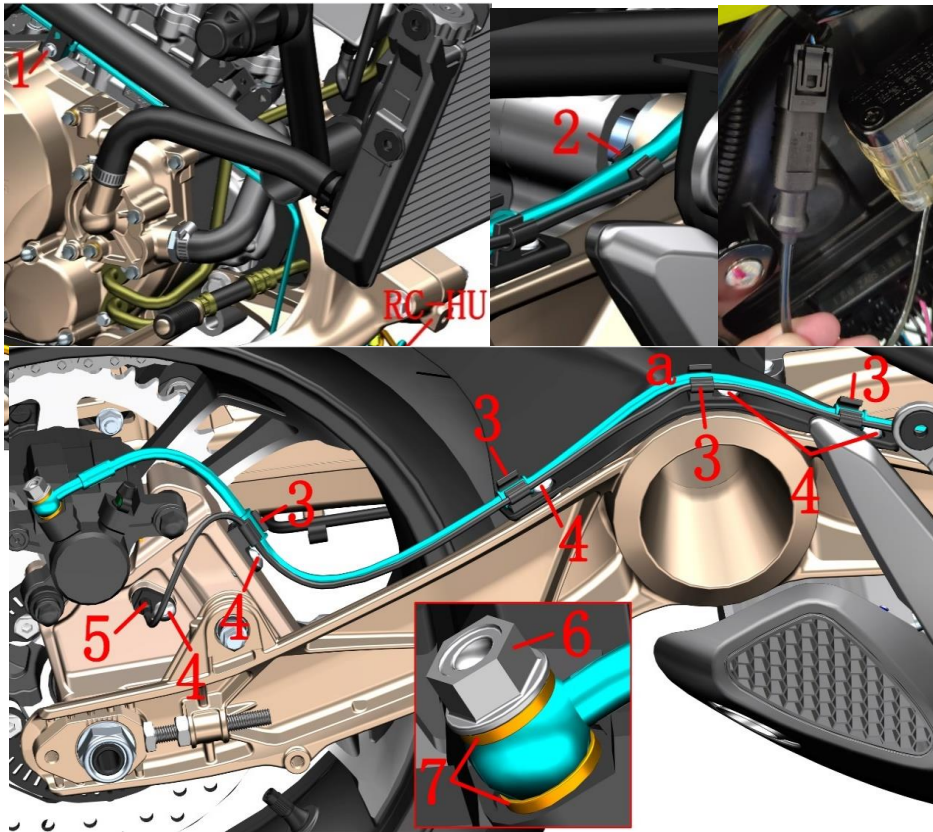

Fig.22FRONT FORK COMPONENT		ABS brake system—5		CHK
				ADJ
NO.	PART NO.	PART NAME	QTY	CAUTION
1	1251100-061093	M6×22 hex flange face full thread bolt	1	
2	1224100-044000	Wheel speed sensor clamp	1	
3	1224200-003000	ZT310—Z rear disc brake pipe clamp	4	
4	1251100-102000	Non—standard bolt M6×16 (304 stainless steel)	5	
5	1181200-118000	Wheel speed sensor(A)	1	
6	1251100-112000	Disc brake tubing bolt M10×1—22	1	32N.m
7	1251513-013000	Brake brake tubing copper washer φ15×φ10.2×1.5	2	

PROCEDURE:

●Rear disc brake caliper

Refer to the steps of removing the rear wheel assembly in the front, remove the rear axle nut and the right chain adjuster, and then retract the rear axle to the left to remove the rear disc brake caliper assembly. Put the rear axle, right chain adjuster and rear axle nut back into the rear fork.

●RC-HU Oil Pipe

Rear disc brake calipers and hydraulic control unit placed under the oil pan

In the previous steps, remove the nut of the pilot control unit and the brake fluid. Connect the RC-HU oil pipe to the hydraulic control unit.

Remove the bolt (1); find the clamp (2) on the back of the right foot and remove it.

Pull the RC-HU oil pipe out of the 4 disc brake tubing clamps (3).

After wearing the waterproof gloves, remove the bolts (6) with a 12# sleeve; remove the copper washers (7). If you need to replace the RC-HU tubing, it is recommended to replace the two copper washers (7) at the same time; the bolts (6) can be replaced if they are not damaged.

●Wheel speed sensor

Remove the wheel speed sensor cable connector and pull it out. Pull the sensor cable out of the 4 disc brake tubing clamps (3). Remove the sensor wire after removing the bolt (4).

●Disc brake pipe clamp

a-For the disassembly and assembly of the disc brake tubing clamp, see the steps in the inner mud plate. Do not loosen the bolts (4) at a if necessary. The other three positions of the tubing clamp can be removed after removing the bolt (4).

CAUTION:

●Be sure to disassemble the muffler and engine after they have cooled down completely. The horizontal support of the vehicle should be fixed before disassembly and assembly work.

●The precautions for brake fluid are described in the previous section.

●The torque of the four oil pipe nut joints at the pilot unit is 18 N.m.

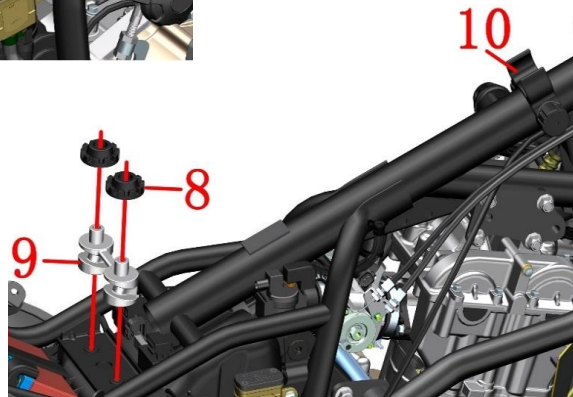
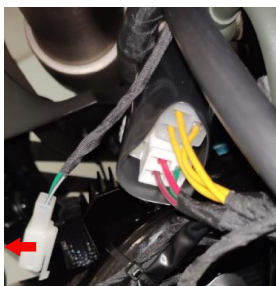
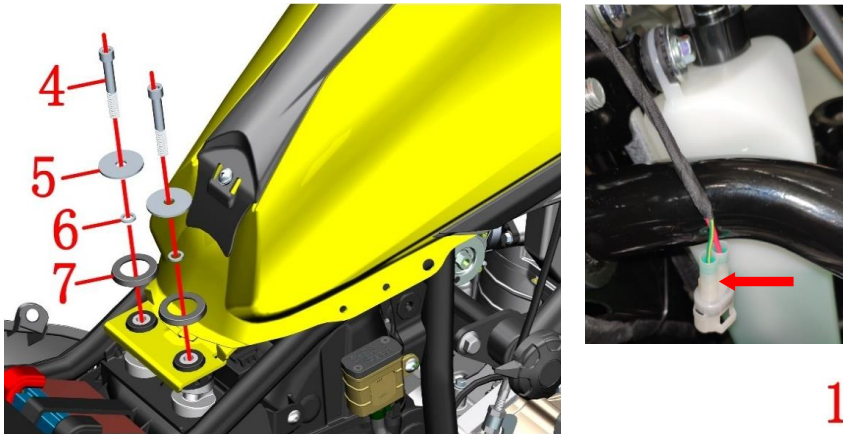
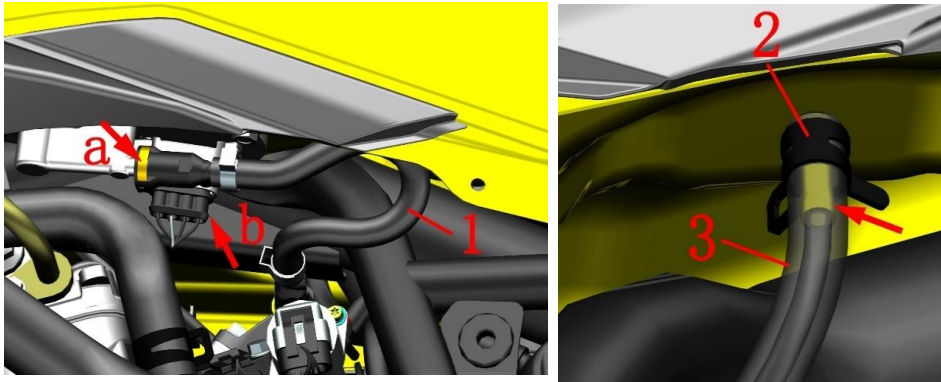

Fig. 1 FUEL TANK COVER COMPONET		Fuel tank assembly	CHK	⚠
			ADJ	
NO.	PART NO.	PART NAME	QTY	CAUTION
1	1050954-027000	ZT310—V EFI high pressure tubing assembly	1	
2	1276001-057000	ZT310 water pipe clamp(φ10.5)(after-sale)	1	
3	1244200-095000	ZT310—V carbon canister adsorption tube (φ5×φ11)	1	
4	1250205-043093	Gb70.1m8×55 (environmental color)	2	
5	1251900-028093	ZT250—R fuel tank flat pad φ9×φ37.5×2	2	
6	1251500-081000	Non—Standard flat pad φ13×φ8.2×1.5 (color zinc)	2	
7	1244100-020000	ZT250—S fuel tank pressure rubber	2	
8	1244100-053000	ZT250—S second generation fuel tank gasket	2	
9	1274100-080000	ZT250—R seat cushion fixing block	1	
10	1244100-019000	ZT250—S tank inner limit rubber	1	

PROCEDURE:

●Fuel tank assembly

Open the fuel tank cover first, and do not close it during the subsequent disassembly.If you accidentally close it, you can find the fuel tank lock plug near the auxiliary water tank. After connecting, re-open the fuel tank cover.

Place the oil pan on the left side under the high pressure oil pipe (1), and press the limit buckle at the direction indicated by the arrow a to pull out at the rear of the car.

Use a pair of pliers to clamp the hoop slightly at the bottom of the right tank and move it down about 30mm, leaving the boss on the tank snorkel.Adsorption tube (3) Remove from the fuel tank.

Remove the bolts (4), remove the flat pads (5) and (6); and press the glue (7).The flat pad (6) was added in mid-August 2019 to prevent excessive compression of the tank rubber and rubber.

Pull the fuel tank assembly slightly behind the rear and lift the rear of the fuel tank assembly up.Do not lift too high to prevent fuel from escaping from the snorkel.Unplug the cable plug b of the oil pump.

Remove the fuel tank gasket (8), the seat cushion fixing block (9), and the tank liner limit rubber from the frame.

CAUTION:

- The fuel tank should be protected during the disassembly process to prevent damage to the paint surface.
- Before disassembling the fuel tank assembly, it is recommended to use the oil pump to pull out the fuel or use off the fuel
- Fireworks, telephone calls should not be allowed near the motorcycle -removal workshop to prevent accidents.
- A small amount of fuel leaks when pulling out the high pressure tubing subassembly, and should prevent the fuel from dripping to the outside of the engine or the muffler.

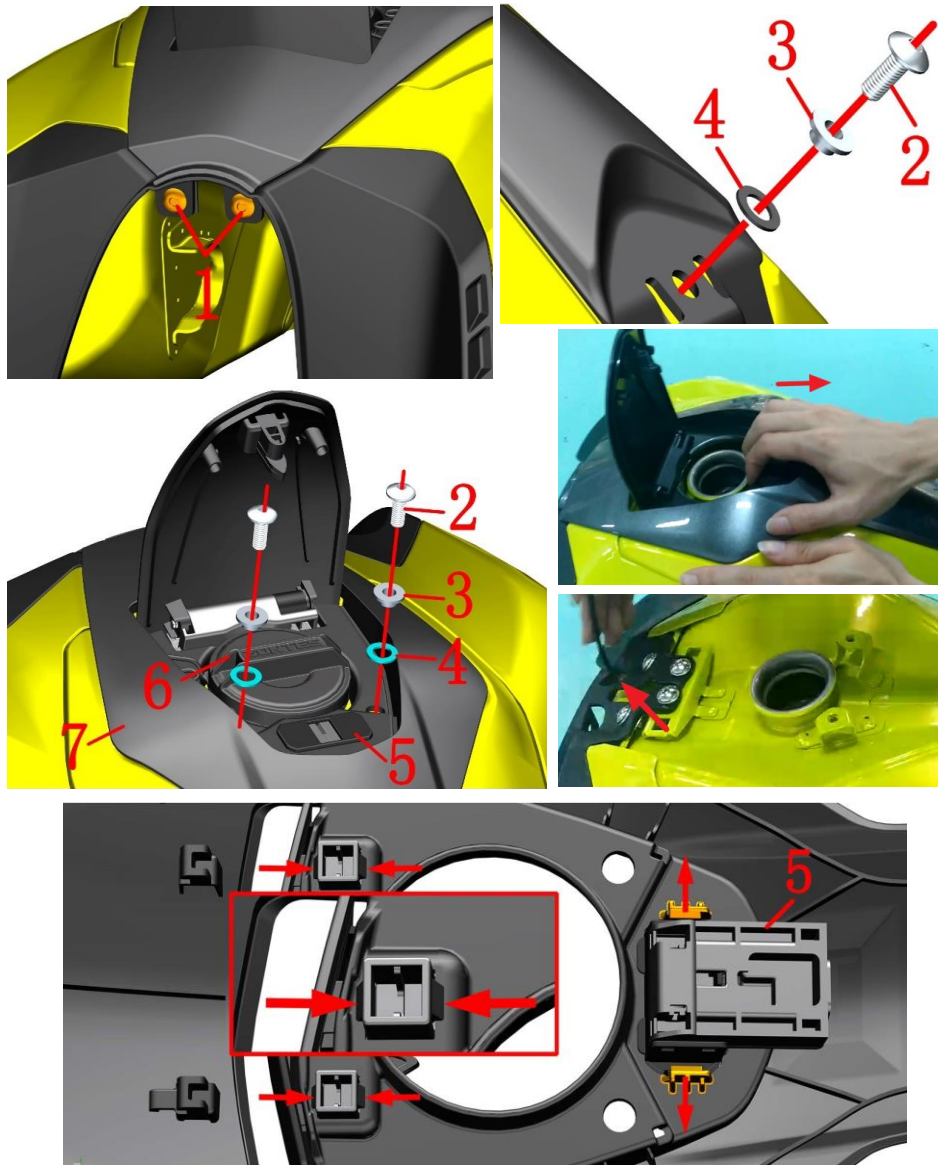

Fig. 2 FUEL TANK COVER COMPONENT		fuel Tank middle cover assembly		CHK	CAUTION
NO.	PART NO.	PART NAME	QTY	ADJ	
1	1224100-089000	ZT250-S Expansion nail(5 pcs/after-sale)	2		
2	1251100-102000	Non—Standard bolt m6×16 (304 stainless steel)	3		
3	1274100-155095	Flanged bushing φ6.2×φ8.4×3.5 + φ14×1.5(5 pcs/after sale)	3		
4	1241200-124021	Hanging bushing buffer rubber (φ8.5×φ14×1)(5 pcs/after sale)	3		
5	1184200-002000	ZT310 electronic fuel tank lock	1		
6	1224100-033000	ZT250—S threaded fuel tank cap	1		
7	4044201-262052	ZT310—V fuel tank cover (dark gray)	1		other color
	4044201-262051	ZT310—V fuel tank cover (titanium matte)		black vehicle	

PROCEDURE:

● Tank middle cover assembly

Remove the two expansion pins (1) of the head.

Remove the bolt (2) at the rear of the middle cover and remove the bushing (3) and cushion rubber (4)

Remove the bolt (2) at the fuel tank cap and remove the bushing (3) and cushion rubber (4).

Take off the fuel tank cap(6).

Pull firmly from the round hole of the tank cover to hear the sound, then grab the sides of the middle cover and lift it up, and pull the fuel tank lock cable from the hole in the middle of the cover.

Put the fuel tank cap (6) back into the fuel tank to prevent fuel volatilization and foreign matter from falling into the tank.

● Fuel tank lock

Flip to the back and use a flat-blade screwdriver to carefully open the middle cover (7) to buckle at both ends, remove the fuel tank lock (5), pay attention to the strength to prevent damage to the buckle.

● Fuel tank cover assembly

Use a needle-nose pliers to clamp the buckle of the swivel bracket with a little force to clamp, remove the cover assembly, and take care of the strength to prevent damage

CAUTION:

● The fuel tank should be protected during the disassembly process to prevent damage to the paint surface.

● Pay attention to the force when removing the buckle to prevent damage to the buckle.

● Fireworks, telephone calls should not be allowed near the motorcycle -removal workshop to prevent accidents.

● A small amount of fuel leaks when pulling out the high pressure tubing subassembly, and should prevent the fuel from dripping to the outside of the engine or the muffler.

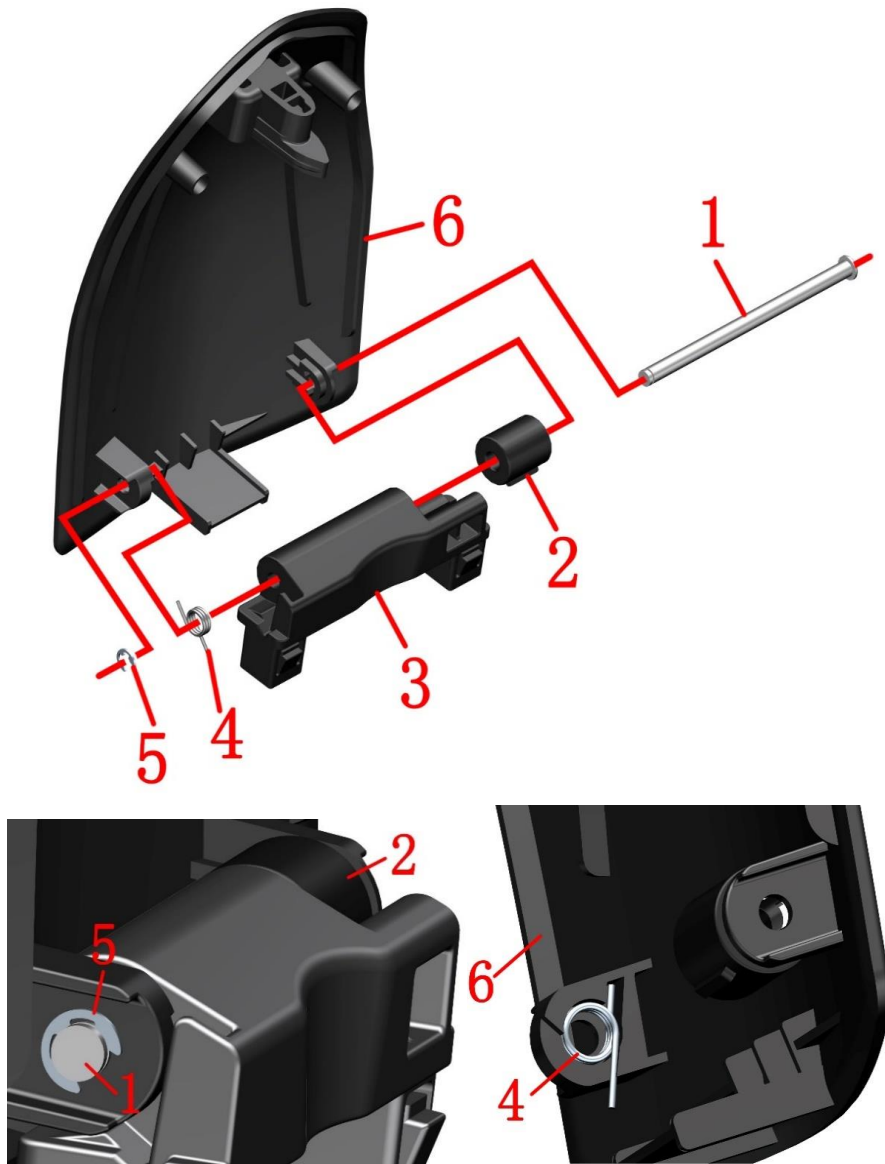

Fig.3 FUEL TANK COVER COMPONET		Change engine oil	CHK	⚠
			ADJ	
NO.	PART NO.	PART NAME	QTY	CAUTION
1	1274101-016000	ZT250-S rotating axle of fuel tank outside cover(after-sale)	1	
2	1224100-014000	ZT250-S fuel tank cover rotary damping	1	
3	1224200-126000	ZT310-V fuel tank cover rotating bracket	1	
4	1260100-255000	ZT250-S torsion spring of tank outer cover rotating shaft	1	
5	1260100-469000	ZT310-V storage box cover rotating shaft limit circlip(5 pcs/after sale)	1	
6	4044201-238052	ZT310-V fuel tank cover (dark gray)	1	【1】
	4044201-238051	ZT310-V fuel tank cover (titanium matte)		

PROCEDURE:

● Fuel tank cover assembly

Remove the retaining spring (5) attached to the rotating shaft (1) and slowly pull out the rotating shaft.

Remove the torsion spring (4) first.

Remove the swivel bracket assembly.

Remove the rotary shaft (1) from the tank cover (6)

Remove the damper (2) from the swivel bracket (3).

CAUTION:

- The parts should be protected during the disassembly process to prevent damage to the paint surface.
- Pay attention to the force when removing the buckle to prevent damage to the buckle.
- When reassembling, note that the torsion spring and damper need to be properly assembled in place.
- 【1】 The dark gray fuel tank cover used for other color motorcycle, the titanium matte used for bright black motorcycle.

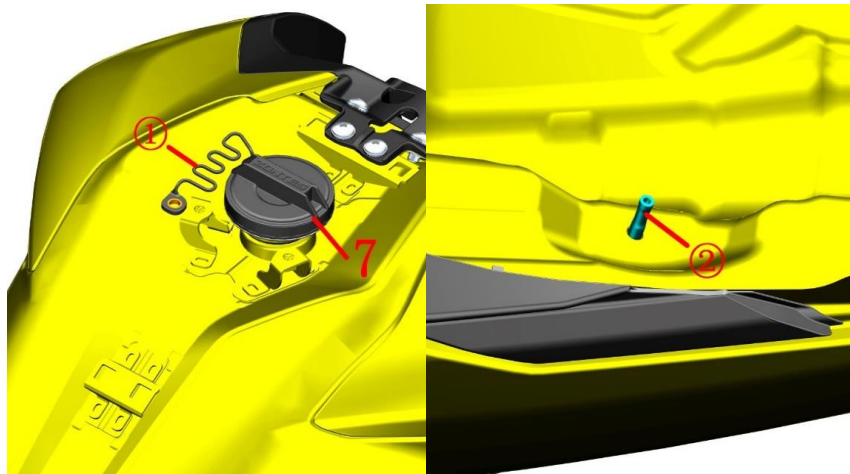
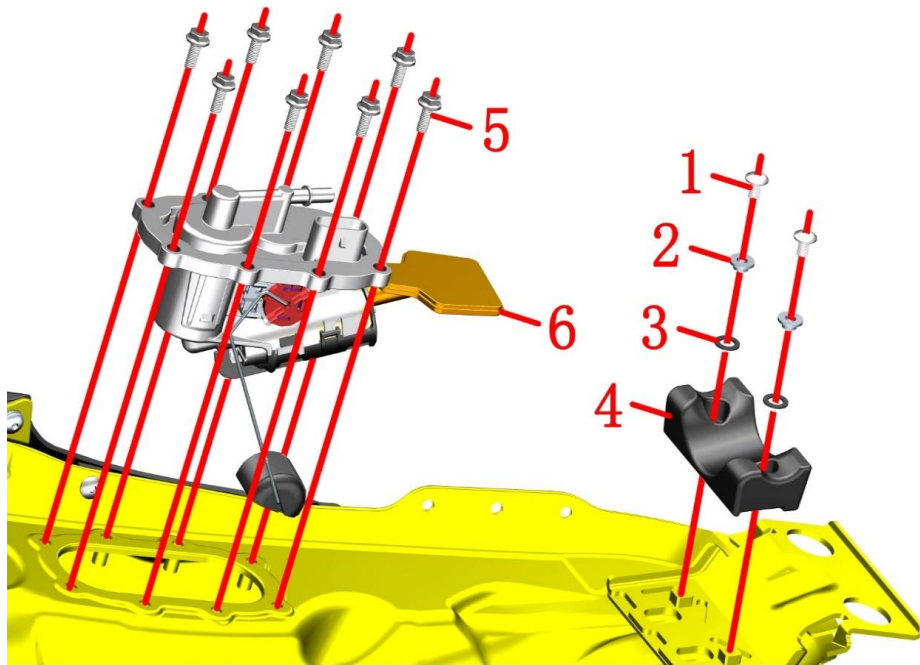

Fig. 4 FUEL TANK COVER COMPONET		Oil pump	CHK	CAUTION
NO.	PART NO.	PART NAME	ADJ	
1	1251100-101000	Non - Standard bolt m6×12 (304 stainless steel)	2	
2	1274100-155095	Flanged bushing φ6.2×φ8.4×3.5 = φ14×1.5 (304 stainless steel)	2	
3	1241200-124021	Hanging bushing barrier rubber (φ8.5×φ14×1)(304 stainless steel)	2	
4	1244200-083000	ZT310 - V fuel tank cushion rubber	1	
5	1250105-137093	Gb5789m6×16 (environmental color)	8	
6	1050954-021000	T02 built-in fuel pump - ZT310v	1	
7	1224100-033000	ZT250 - S threaded fuel tank cap	1	

PROCEDURE:

- Fuel tank cushion rubber
Remove the bolts (1) and remove the oil bushing (2) and the cushion rubber (3). Remove the tank cushion rubber (4).
- Fuel pump
Remove 8 bolts (5).
When the fuel pump (6) is removed, the float connecting rod cannot be bent to avoid inaccurate oil display. After removing the fuel pump, it is recommended to temporarily seal the oil pump port to prevent something falling into the tank.
- Fuel tank cap
Flip to the front of the tank assembly, turn the tank cap (7) counterclockwise and remove. Be careful not to pull the nylon cord ① during the removal process.

CAUTION:

- Before disassembling the fuel tank assembly, it is recommended to use the oil pump to pull out the fuel or use off the fuel
- Fireworks, telephone calls should not be allowed near the motorcycle -removal workshop to prevent accidents.
- When reversing the fuel tank inner assembly, remove the fuel pump and check that the fuel tank cap is tightened to prevent the remaining fuel from overflowing from the fuel tank port; the vent pipe 2 may have a small amount of fuel overflow when the fuel tank cap is turned back.
- When reassembling the fuel pump, be sure to clean the joint surface of the fuel pump sealant and the tank liner. When locking the bolt, the position should be locked to ensure uniform deformation of the seal gasket.

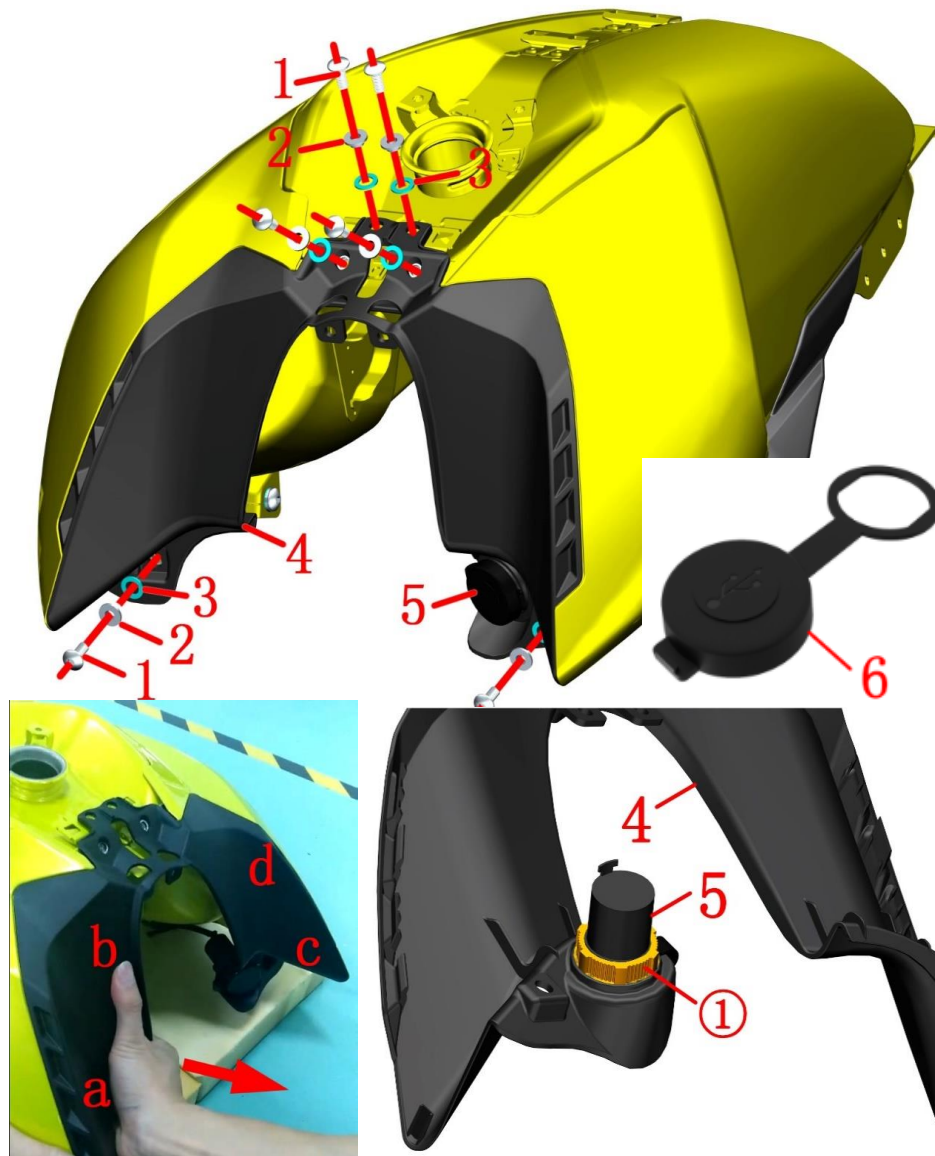

Fig. 5 FUEL TANK COVER COMPONET		Fuel tank front trim cover	CHK	⚠
			ADJ	
NO.	PART NO.	PART NAME	QTY	CAUTION
1	1251100-102000	Non – Standard bolt m6×16 (304 stainless steel)	6	
2	1274100-155095	Flanged bushing $\phi 6.2 \times \phi 8.4 \times 3.5 + \phi 14 \times 1.5$ (5 pcs/after-sale)	6	
3	1241200-124021	flanging bushing buffer rubber ($\phi 8.5 \times \phi 14 \times 1$) (5 pcs/after-sale)	6	
4	1224200-119000	ZT310 – V fuel tank middle decoration cover	1	
5		Usb charging cable	1	
6		Usb charging cable cover	1	After sale

PROCEDURE:

● Fuel tank middle decorative cover

Remove the bolts (1) separately; remove the bushing (2) and the cushion rubber (3).

As lower left corner pictures showed, one hand is placed against the fuel tank assembly, and pulled the middle part of the middle of the decorative cover (4) with another hand follow the direction of the arrow.

Pull out the bottom and then pull out the right middle b, the left lower c and the left middle d. Remove the decoration cover assembly.

Flip to the back to remove the nut 1 from the usb charging cable, and remove the usb charging cable from the decoration cover.

The rubber cover (6) is an after-sales piece, and the charging cable has one piece. Used for replacement of the usb charging cable cover after aging.

CAUTION:

● The parts should be protected during the disassembly process to prevent damage to the paint surface. The decorative cover is long and should be handled or held by both hands during.

● Be careful not to pull the usb charging cable when removing the middle of the trim cover.

● Install the buckles in the order of a-b-c-d, and then install the bolts.

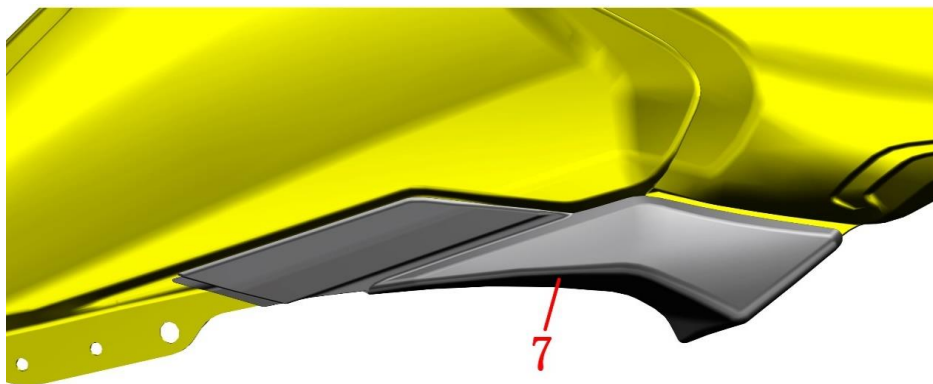
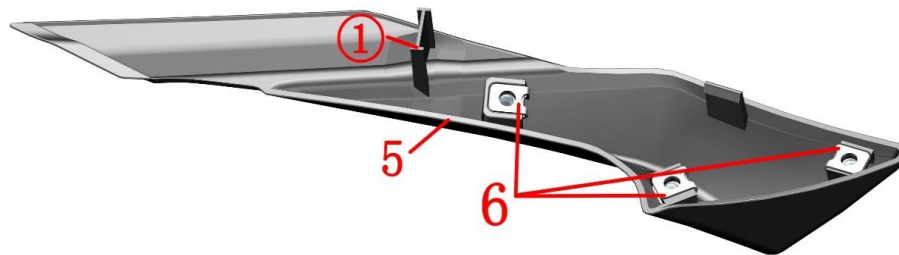
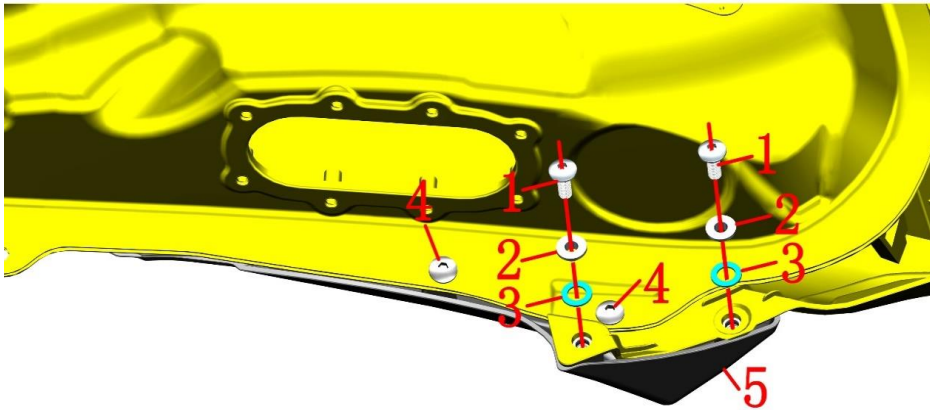

Fig. 6 FUEL TANK COVER COMPONENT		Lower tank cover	CHK	CAUTION
NO.	PART NO.	PART NAME	ADJ	
1	1251100-102000	Non – Standard bolt m6×16 (304 stainless steel)	1	
2	1274100-155095	Flanged bushing φ6.2×φ8.4×3.5 + φ14×1.5(5 pcs/after-sale)	10	
3	1241200-124021	flanging bushing buffer rubber (φ8.5×φ14×1)(5 pcs/after-sale)	10	
4	1251100-101000	Non – Standard bolt m6×12 (304 stainless steel)	4	
5	4044201-235051	ZT310 – V fuel tank left decorative cover lower part (dark gray matte)	1	
6	1251300-063093	Splint m6×11×15 (environmental color)	6	
7	4044201-236051	ZT310 – V fuel tank right decorative cover lower part (dark gray matte)	1	

PROCEDURE:

- Left fuel tank decoration cover lower assembly .
Remove the two bolts (1) and remove the bushing (2) and cushion rubber (3)
Remove the two bolts (4).
Remove the lower part of the left decoration cover from the fuel tank assembly.
- Right tank trim cover lower assembly
Refer to the above steps to remove the right decoration cover lower part (7) and the cleat nut (6).

CAUTION:

- The parts should be protected during the disassembly process to prevent damage to the paint surface.
- Before replacing the lower part of the new decorative cover, check whether the process clip 1 has been cut short. If it is not, cut it first and then assemble it.

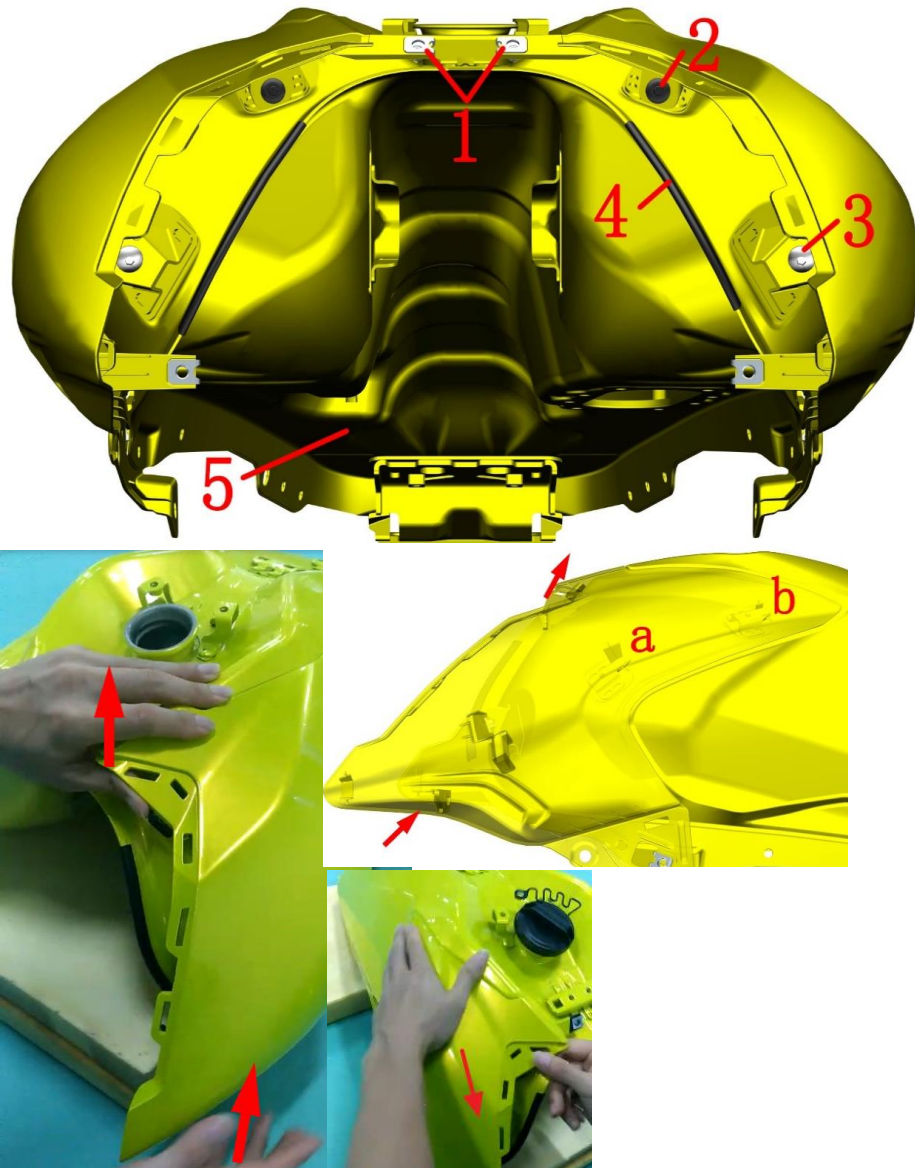

Fig. 7 FUEL TANK COVER COMPONET		Fuel tank trim cover assembly 1		CHK	⚠
				ADJ	
NO.	PART NO.	PART NAME	QTY	CAUTION	
1	1251300-063093	Splint m6×11×15 (color zinc)	4		
2	1224100-089000	ZT250-S Expansion nail(5 pcs/after-sale)	2		
3	1251100-101000	Non—Standard bolt m6×12 (304 stainless steel)	2		
4	1240300-397021	HJ125-6 pod glass strip (1.5m)(after-sale)	0.17		
5	4034200-010015	ZT310—V bright red fuel tank	1	Bright red	
	4034200-010031	ZT310—V bright yellow fuel tank		Bright yellow	
	4034200-010021	ZT310—V bright black fuel tank		Bright black	
	4034200-010002	ZT310—V bright white fuel tank		Bright white	
	4034200-010061	ZT310—V bright purple fuel tank		Bright purple	

PROCEDURE:

- Fuel tank decoration cover assembly
- Remove the 4 plywood nuts (1)
- Remove the two expansion pins (2)
- Remove the two bolts (3).
- As shown in the lower left corner, first push the upper part of the decorative cover upwards with the left thumb, and tap the right hand diagonally upwards to remove the left decorative cover assembly from the fuel tank.
- Remove the right decoration cover assembly in the same way.
- Remove the strips on the left and right sides (4).

CAUTION:

- The parts should be protected during the disassembly process to prevent damage to the paint surface.
- Pay attention to the direction of force, and then remove the trim cover from the tank liner and then remove it.
- When installing, first fasten the buckles at both a and b, and then tap it diagonally downward.

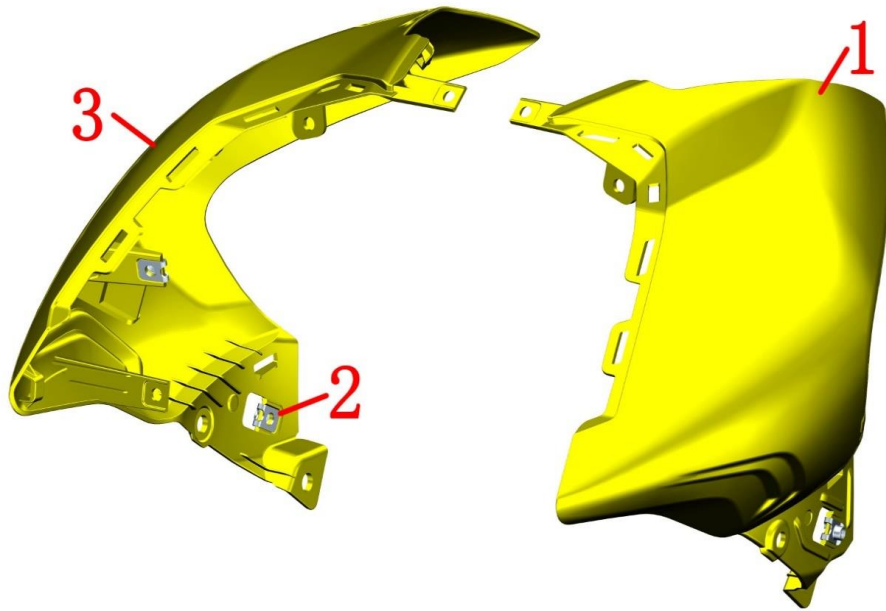

Fig. 8 FUEL TANK COVER COMPONENT		Fuel tank trim cover assembly 2	CHK	CAUTION
			ADJ	
NO.	PART NO.	PART NAME	QTY	
1	4044201-239015	ZT310-V fuel tank left decorative cover (bright red)	1	
	4044201-239031	ZT310-V fuel tank left decorative cover (bright yellow)		
	4044201-239021	ZT310-V fuel tank left decorative cover (bright black)		
	4044201-239002	ZT310-V fuel tank left decorative cover (bright white)		
	4044201-239061	ZT310-V fuel tank left decorative cover (bright purple)		
2	1251300-063093	Splint M6×11×15 (color zinc)	4	
3	4044201-240015	ZT310-V fuel tank right decorative cover (bright red)	1	
	4044201-240031	ZT310-V fuel tank right decorative cover (bright yellow)		
	4044201-240021	ZT310-V fuel tank right decorative cover (bright black)		
	4044201-240002	ZT310-V fuel tank right decorative cover (bright white)		
	4044201-240061	ZT310-V fuel tank right decorative cover (bright purple)		

PROCEDURE:

- Fuel tank decoration cover assembly

Remove the cleat nut (2) from the left decoration cover (1) or the right decoration cover (3), respectively.

CAUTION:

- The parts should be protected during the disassembly process to prevent damage to the paint surface.

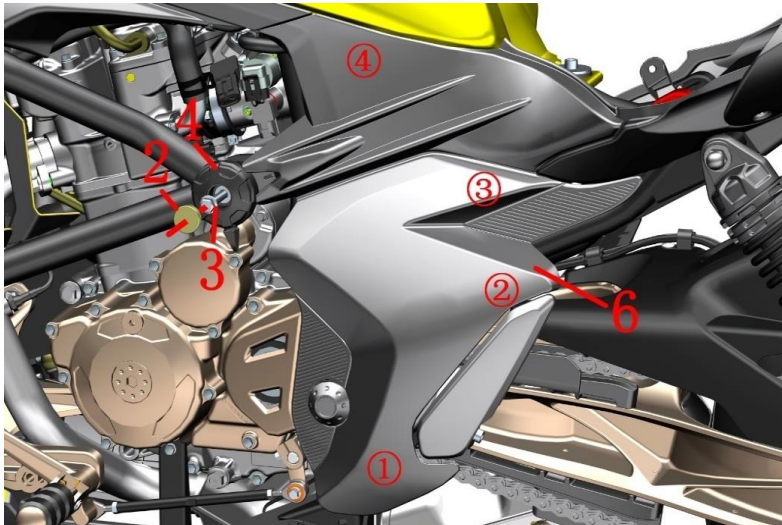
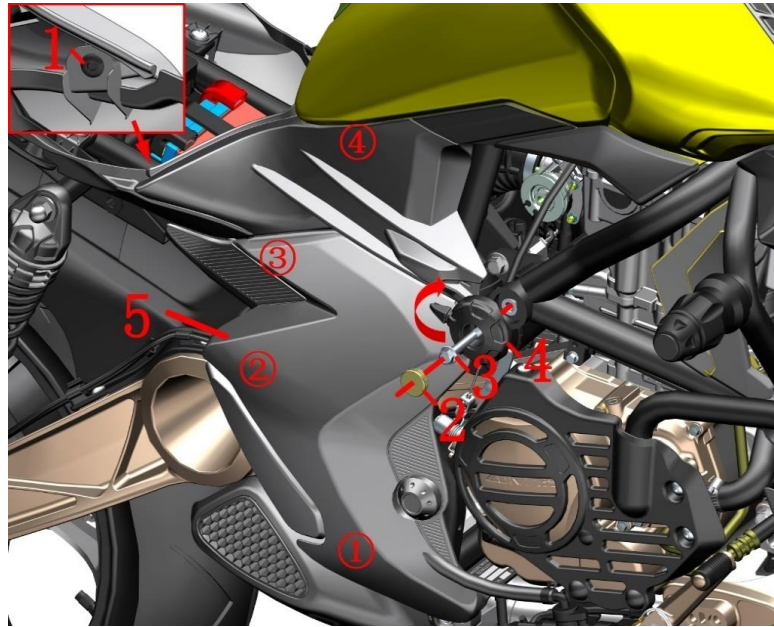

Fig.1 SIDE COVER COMPONENT		SIDE COVER COMPONENT	CHK	⚠
NO.	PART NO.	PART NAME	ADJ	
1	1224100-089000	ZT250-S Expansion nail(5 pcs/after-sale)	2	
2	1244100-061000	ZT250 anti-water rubber of frame	2	
3	1250105-018091	GB5789 M8×70 (white zinc)	2	
4	4044201-256051	ZT310-V Bumper decorative ball (Dark gray matte)	2	
5	4044201-301051	ZT310-V Right side cover (Dark gray matte/Red stickers/V310)	1	red
	4044201-303051	ZT310-V Right side cover (Dark gray matte/Yellow stickers/V310)		yellow
	4044201-297051	ZT310-V Right side cover (Dark gray matte/Black stickers/V310)		black
	4044201-305051	ZT310-V Right side cover (Dark gray matte/White stickers/V310)		white
	4044201-299051	ZT310-V Right side cover (Dark gray matte/Purple stickers/V310)		purple
6	4044201-300051	ZT310-V Left side cover (Dark gray matte/Red stickers/V310)	1	red
	4044201-302051	ZT310-V Left side cover (Dark gray matte/Yellow stickers/V310)		yellow
	4044201-296051	ZT310-V Left side cover (Dark gray matte/Black stickers/V310)		black
	4044201-304051	ZT310-V Left side cover (Dark gray matte/White stickers/V310)		white
	4044201-298052	ZT310-V Left side cover (Dark gray matte/Purple stickers/V310)		purple

PROCEDURE:

● Side cover

First remove the seat cushion and then remove the expansion screw (1) at the joint between the right side cover (5) and the tail cover. Remove the water stopper (2) and loosen the bolt (3) with the T12 socket without completely removing it. Pull the decorative ball (4) out and turn it clockwise, stagger the groove on the right side cover. Pull out the right side cover in the order of ①-②-③-④.

Remove the left side cover (6) using the same steps as above.

CAUTION:

● When inserting, install the staples by ④-③-②-①; finally install the expansion screw.

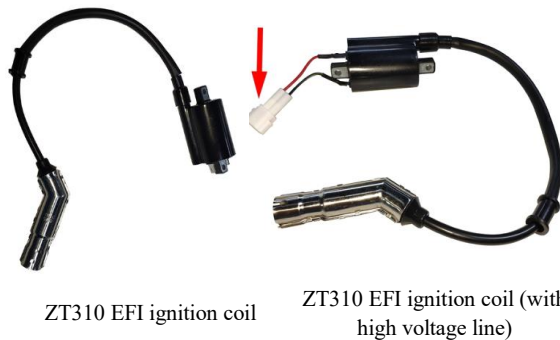
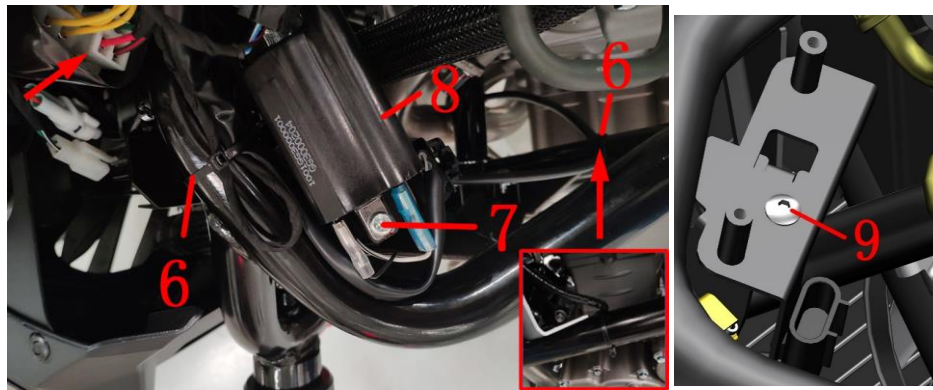
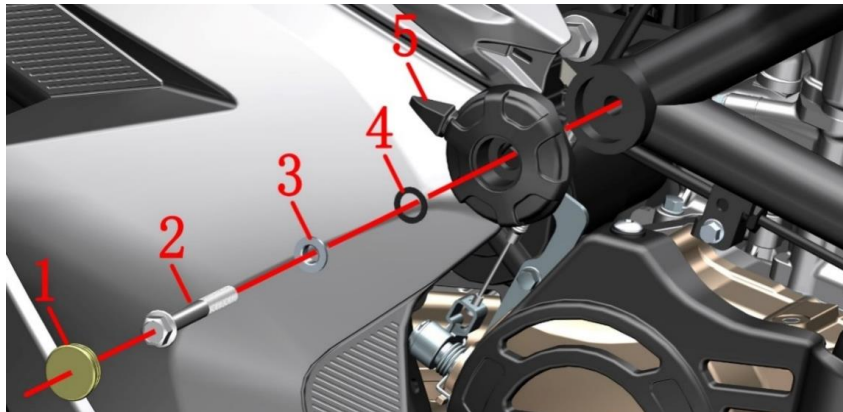

ZT310 EFI ignition coil

ZT310 EFI ignition coil (with high voltage line)

Fig.1 GUARD BAR COMPONENT		Guard bar assembly 1		CHK	CAUTION
NO.	PART NO.	PART NAME	QTY	ADJ	
1	1244100-061000	ZT250 anti-water rubber of frame	2		
2	1250105-018091	GB5789 M8×70 (white zinc)	2		
3	1251700-058093	Flanging bushing φ8.2×φ11×4.5+φ16×1.5(environmental color)	2		
4	1240300-071000	Flanging bushing rubber (φ11×φ16×1)	2		
5	4044201-256051	ZT310-V Bumper decorative ball (Dark gray matte)	2		
6	1226000-218000	Grade 0 flame retardant tie (black 3.6×295)(5 pcs/after-	2		
7	1250201-032093	GB818M5×16 (environmental color)	2		
8		ZT310 electric jet ignition coil	1		
9	1251100-101000	Non-standard bolt M6×12 (304 stainless steel)	1		

PROCEDURE:

- Bumper decorative ball
Remove the water stopper(1); Remove the bolt(2), the bushing(3) and buffer rubber(4), Remove the bumper decorative ball (5).
Use the same method to remove the decorative ball on the left side.
- Remove the left and right side covers and the fuel tank assembly by referring to the steps of removing the side cover and the fuel tank assembly.
- Pull out the two cable plugs of the rectifier. Cut the two straps (6); remove the two bolts (7) and remove the ignition coil to expose the bolts (9).
- Remove the bolt (9) and move the ignition coil bracket and the oxygen sensor wire back together to completely expose the bracket on the guard bar.

CAUTION:

- The seat cushion, side cover, fuel tank assembly, etc. must be removed in advance.
- When removing the high-pressure oil pipe, be sure to wait until the engine and muffler are completely cooled before operating to prevent accidental ignition of the fuel and cause fire.
- Fireworks, answering or dialing should be strictly prohibited near the car-breaking site to prevent accidents.
- A small amount of fuel leakage is required when the high-pressure oil pipe sub-assembly is pulled out, and the fuel should be prevented from dripping to the outside of the engine or the muffler.

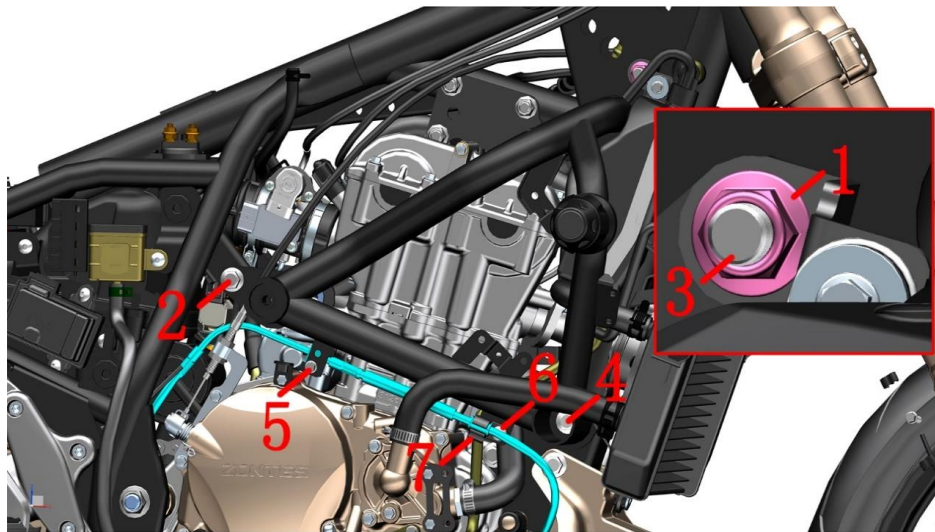
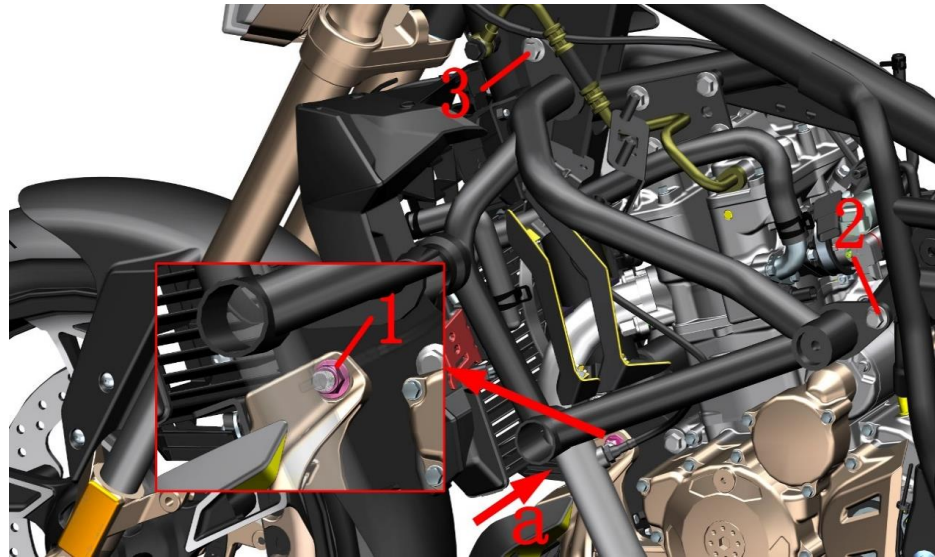

Fig.2 GUARD BAR COMPONENT		Guard bar assembly 2		CHK	⚠
				ADJ	
NO.	PART NO.	PART NAME	QTY	CAUTION	
1	1251300-057093	Non-standard nuts M10×1.5 (color zinc)	2		
2	1251100-082093	Non-standard bolt M10×1.5×20	2		
3	1251100-132003	Non-standard bolt M10×1.5×80	1		
4	1251100-137000	Non-standard boltM10×1.5×100	1		
5	1251100-061093	M6×22 Hex flang bolt thread level 8.8 (color zinc)	1		
6	1251100-101000	Non-standard bolt M6×12 (304 stainless steel)	1	after 2021	
7	1224200-003000	ZT310—R Rear disc brake pipe clamp	1		
8	4024200-054000	ZT310—V Guard bar connecting pipe	1		

PROCEDURE:

● **Bumper assembly**

In the gap between the left radiator and the deflector, insert a #14 wrench into the nut (1), and remove the bolt(4) on the right side.

Remove the bolt (2) on the right side and the bumper connecting tube.

The motorcycles after production 2021 need remove the oil pipe from the clamp(7), then remove the bolt(6).

Fix the head of the bolt (3) with a socket and remove the nut (1) on the right side.

After holding the left and right bumper, remove the bolt (2) on the right side and remove the right bumper assembly.

Hold the left bumpe assembly and pull out the bolts(s). Make sure that the cable ties,cables, etc. on the left bumper assembly have been removed and the left bumper assembly is removed.

CAUTION:

- Be careful not to pull the oxygen sensors wire when removing the left bumper assembly
- Be careful not to press any cables when reassembling



Left bumper assembly

Right bumper assembly

Bumper connecting tube

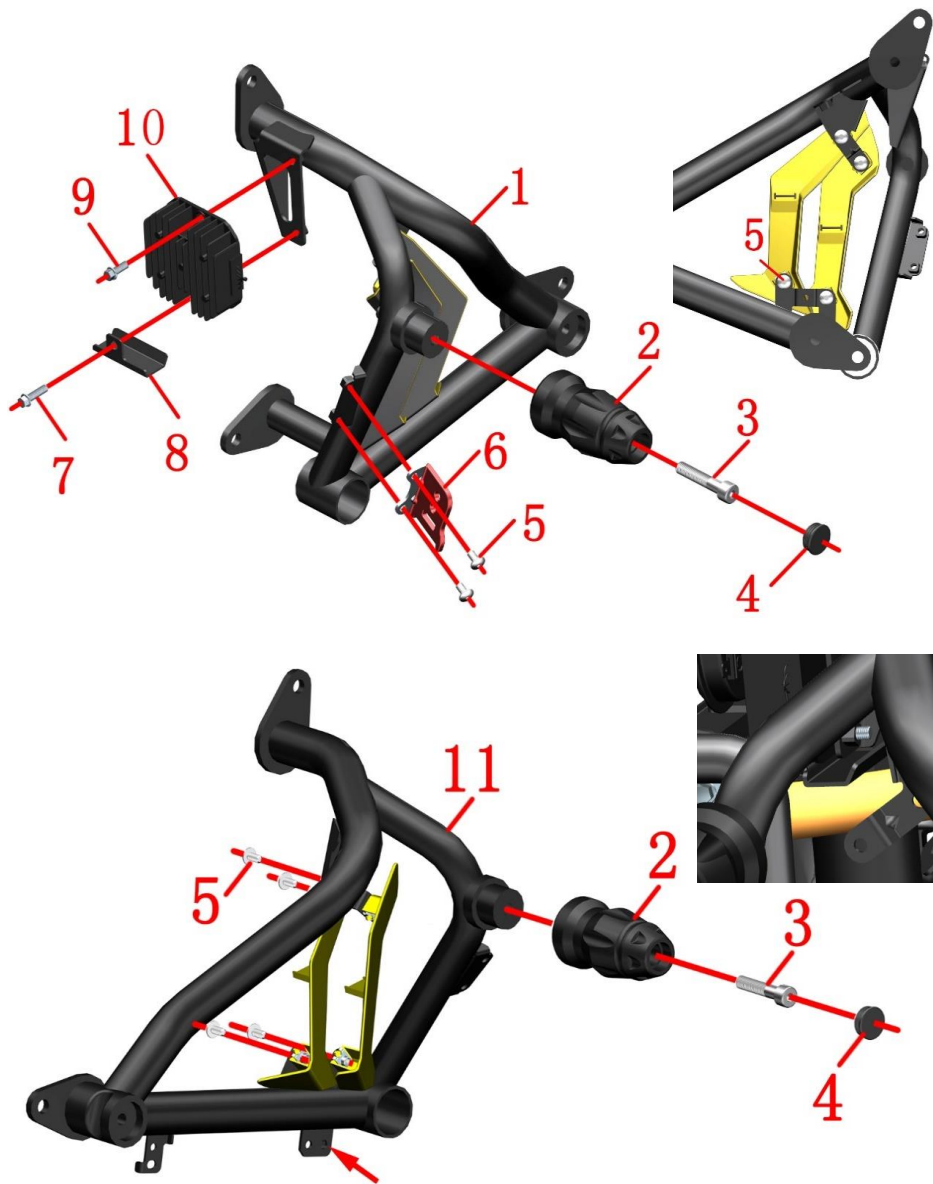

Fig.3 GUARD BAR COMPONENT		Guard bar assembly 3	CHK	CAUTION
NO.	PART NO.	PART NAME	ADJ	
1		ZT310—V Left bumper assembly	1	
2	1244100-089000	ZT250-R guard bar anti-drop glue (outside association)	2	
3	1251100-083094	Non-standard bolt M10×1.5×50 (black zinc)	2	
4	1244100-061000	ZT250 anti-water rubber of frame	2	
5	1251100-101000	Non-standard bolt M6×12 (304 stainless steel)	10	
6	1274200-037000	ZT310—R support of disc brake lock	1	
7	1251100-061093	M6×22 Hex flange bolt thread level 8.8 (color zinc)	1	
8	1274200-183000	ZT310—V Outlet pipe bracket	1	
9	1251112-001093	M6×16 Hexagon flange bolts (color zinc)	1	
10		Rectifier	1	
11		Right bumper assembly	1	

PROCEDURE:

●Left bumper assembly

- Remove the water stopper (4), the bolt (3), and the protection rubber (2).
- Remove the bolt (5) and the disc brake lock bracket (6).
- Remove the bolt (7) and the outlet pipe bracket (8).
- Hold the rectifier (10) and remove the bolt (9) then remove it.
- Remove the 4 bolts (5) and remove the engine decorative cover assembly.

●Right bumper assembly

- Follow the steps above to remove the right bumper (11).

CAUTION:

- Protect the engine decorative cover paint to prevent scratches.
- The disc brake lock bracket is only suitable for TOP DOG disc brake lock RE008 and TOP DOG disc brake lock RE0081 two models, other models are not adapted.
- When reassembling, pay attention to the radiator outlet pipe below the outlet pipe bracket.

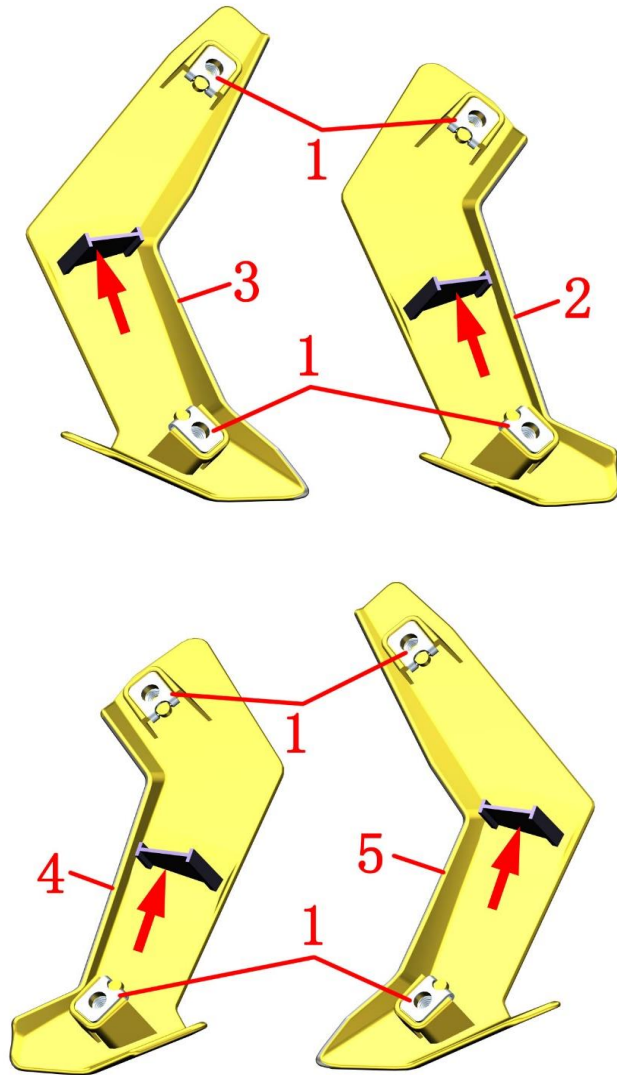

Fig.4 GUARD BAR COMPONENT		Engine decorative cover components	CHK	CAUTION
NO.	PART NO.	PART NAME	ADJ	
1	1251300-063093	plywood M6×11×15 (color zinc)	8	
2	4044201-344051	Engine decorative cover left front (Dark gray matte red)	1	red
	4044201-336051	Engine decorative cover left front (Dark gray matte yellow)		yellow
	4044201-246051	Engine decorative cover left front (Dark gray matte)		black
	4044201-340051	Engine decorative cover left front (Dark gray matte white)		white
	4044201-348051	Engine decorative cover left front (Dark gray matte purple)		purple
3	4044201-345051	Engine decorative cover left back (Dark gray matte red)	1	red
	4044201-337051	Engine decorative cover left back (Dark gray matte yellow)		yellow
	4044201-247051	Engine decorative cover left back (Dark gray matte)		black
	4044201-341051	Engine decorative cover left back (Dark gray matte white)		white
	4044201-349051	Engine decorative cover left back (Dark gray matte purple)		purple
4	4044201-342051	Engine decorative cover right front (Dark gray matte red)	1	red
	4044201-334051	Engine decorative cover right front (Dark gray matte yellow)		yellow
	4044201-248051	Engine decorative cover right front (Dark gray matte)		black
	4044201-338051	Engine decorative cover right front (Dark gray matte white)		white
	4044201-346051	Engine decorative cover right front (Dark gray matte purple)		purple
5	4044201-343051	Engine decorative cover right back (Dark gray matte red)	1	red
	4044201-335051	Engine decorative cover right back (Dark gray matte yellow)		yellow
	4044201-249051	Engine decorative cover right back (Dark gray matte)		black
	4044201-339051	Engine decorative cover right back (Dark gray matte white)		white
	4044201-347051	Engine decorative cover right back (Dark gray matte purple)		purple

PROCEDURE:

●Left engine decorative cover assembly

- 1.Remove the two nuts (1) from the left front decorative cover (2) of the engine.
- 2.The same method remove the nuts (1) from the left back decorative (3), the right front decorative cover (4), and the right back decorative cover (5).

CAUTION:

- Protect the engine decorative cover paint to prevent scratches.
- Before replacing the engine decorative cover, check whether the clip indicated by the arrow has been cut short,if not, cut it first and then assemble it on the bumper.

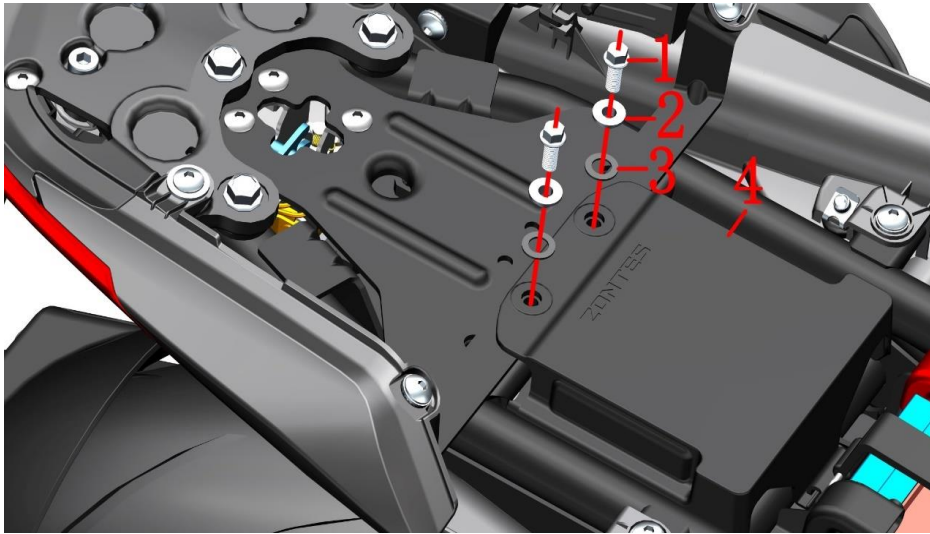

Fig.1 REAR COVER COMPONENT		Electric device box cover component	CHK	⚠
			ADJ	
NO.	PART NO.	PART NAME	QTY	CAUTION
1	1251112-001093	M6×16 Hexagon flange bolts (color zinc)	2	
2	1274100-155095	Flanged bushing φ6.2×φ8.4×3.5+φ14×1.5(5 pcs/after-	2	
3	1241200-124021	flanging bushing buffer rubber (φ8.5×φ14×1)(5 pcs/af	2	
4	1224200-112000	ZT310 -V Electrical device box cover	1	
5	1244100-072000	ZT250-R Battery straps	1	
6	1184100-116000	ZT250 lithium battery	1	

PROCEDURE:

●Electrical device box cover

Remove the bolt (1) , remove the bushing (2) and cushion rubber (3)

Remove Electrical device box cover (4)

Hold the metal clasp (5) on the side near PKE and pull down, then remove the packing band.

●Battery

Unscrew the black protective cap to remove the negative pole; then remove the red protective cap and remove the positive pole; remove the battery. For reinstallation, connect the positive electrode first, then connect the negative electrode. No parallel battery charging or ignition.

Remove the PKE cover and pull the charging connector out. Unplug the charger and plug it into a dedicated lithium battery charger for manual charging. Pay attention to fire and ventilation during charging. Be careful not to overcharge the charging time.



CAUTION:

●Remove side covers and seat cushions in advance.

●The material should be protected during discomponent to prevent damage to the paint.

●Be careful not to overcharge the charging time. About the use and maintenance of the battery see the instructions.

●The battery voltage should be checked regularly. If it is lower than 12.5V, it is recommended to charge it in time; it must not be overcharged; it should be taken out of storage for a long time without being used, and it should be charged once a month.

●Reassemble the battery or fuse, etc. Remember to remember to reset the EFI hardware: Turn on the key-ignition- 10 seconds After the ignition is turned off - After 10 seconds Turn on the ignition switch and repeat 2 times.

●If the battery has reached the end of its useful life, it should be handed over to a qualified organization or a dedicated recycling center for proper disposal. Discard it at will.

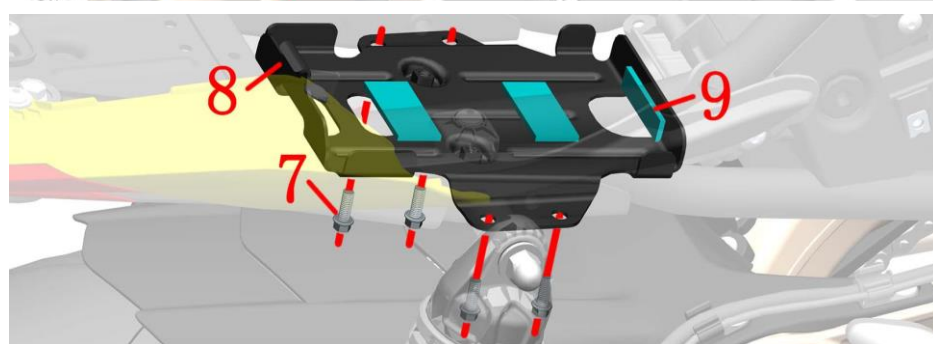
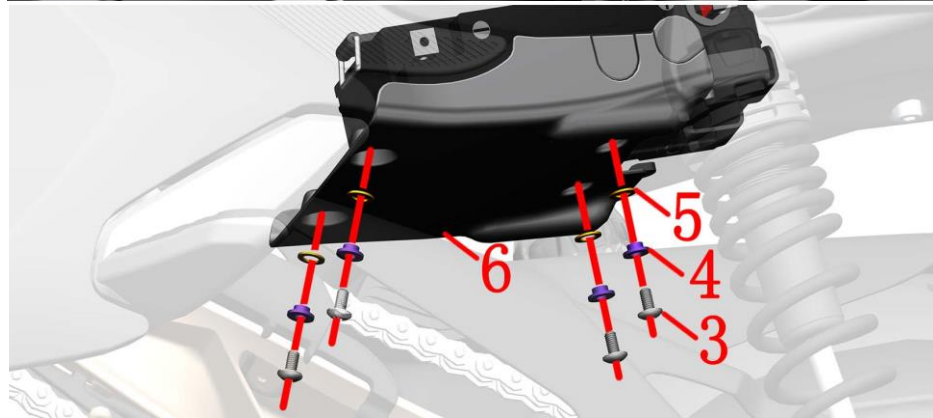

Fig.2 REAR COVER COMPONENT		Electrical device box component (colloid battery)	CHK	⚠
NO.	PART NO.	PART NAME	ADJ	
1	1244200-111000	ZT310 Gel Battery Bands	1	
2	1184200-099000	ZT310 colloid battery (6-FM-10/10Ah)	1	
3	1251100-101000	Non-standard bolt M6×12 (304 stainless steel)	4	12±1.5N.m
4	1274100-155095	Flanged bushing φ6.2×φ8.4×3.5 + φ14×1.5(5 pcs/after sale)	4	
5	1241200-124021	Flanging bushing barrier rubber (φ8.5×φ14×1)(5 pcs/after sale)	4	
6	4044201-467051	ZT310-VX battery bottom cover (dark gray matte)	1	
7	1251112-001093	M6×16 hexagon flange bolts (environmental protection color zinc)	4	12±1.5N.m
8	1274200-273000	ZT310-VX battery holder	1	
9	1241200-125000	HJ125-6 Battery rubber gasket(5 pcs/after-sale)	3	

PROCEDURE:

● Battery

Pull the battery strap (1) pull down to loosen the metal buckle, remove the battery strap (1), unplug the black negative protective cap of the main wiring harness, and remove the bolts that come with the battery with a cross. Remove the battery negative wire first, and then remove the positive wire, then the battery(2) can be removed.

● Battery bottom cover

Remove the four bolts (3), remove the four flanging bushings (4) and the four flanging bushing cushion rubbers (5), then the battery bottom cover (6) can be removed.

● Battery holder

Use a 8# sleeve to remove the four bolts (7), and then take off the battery holder (8).

CAUTION:

- Remove side covers and seat cushions in advance.
- The material should be protected during discomponent to prevent damage to the paint.
- Be careful not to overcharge the charging time. About the use and maintenance of the battery see the instructions.
- Reassemble the battery or fuse, etc. Remember to remember to reset the EFI hardware: Turn on the key-Ignition- 10 seconds After the ignition is turned off - After 10 seconds Turn on the ignition switch and repeat 2 times.
- If the battery has reached the end of its useful life, it should be handed over to a qualified organization or a dedicated recycling center for proper disposal. Discard it at will.

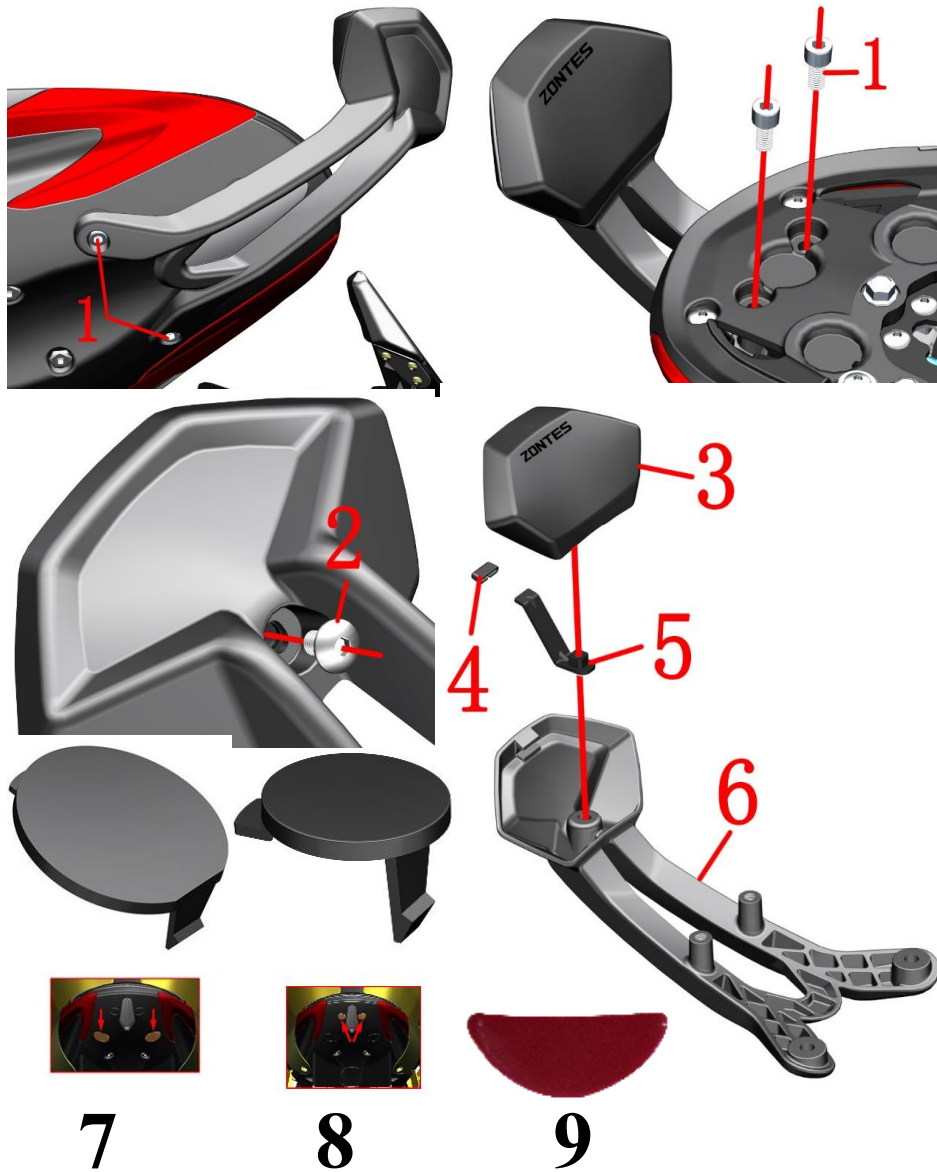

Fig.3 REAR COVER COMPONENT		Backrest assembly componen	CHK	CAUTION
NO.	PART NO.	PART NAME	ADJ	
1	1250205-040095	GB70.1 inner hex bolt M8×16 (color Zinc)	4	
2	1251100-101000	Non-standard bolt M6×12 (304 stainless steel)	1	
3	1244200-062100	ZT310-V backrest rubber (improved)	1	
4	1244200-005000	ZT310-R buffer rubber of head cover	1	
5	1274200-146000	ZT310-V rear backrest rubber holder	1	
6	4024200-053051	ZT310-V rear backrest	1	
	4024200-074051	ZT310-V rear backrest (dark gray matte)		
7	4044201-257051	ZT310-V rear decoration cover front cover	2	without backrest
8	4044201-258051	ZT310-V rear decoration cover rear cover	2	
9	1244200-090000	Double sided tape for the front small cover of the rear decoration cover	4	

PROCEDURE:

● Backrest assembly componen

Remove the bottom two bolts (1).

Support the backrest assembly and remove the upper two bolts (1). Remove the backrest assembly from the vehicle.

Flip to the back and remove the bolts (2).

Divided the backrest (6) and backrest rubber (3).

Remove the holder (5) from the backrest. Remove buffer (4) from the holder.

● without backrest

If without the backrest will send four units small cover and double tape to block up the hole of the rear backrest.

CAUTION:

● Remove the side cover, seat cushion, and cover decoration cover in advance.

● The material should be protected during discomponent to prevent damage to the paint.

● If want to change the old backrest rubber as the new one Need to polish off the two convex boss on old backrest.

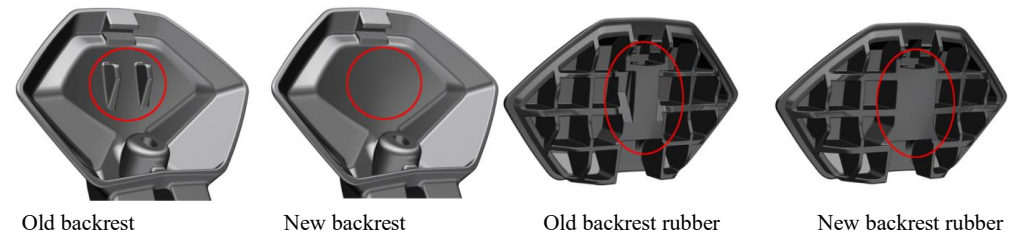

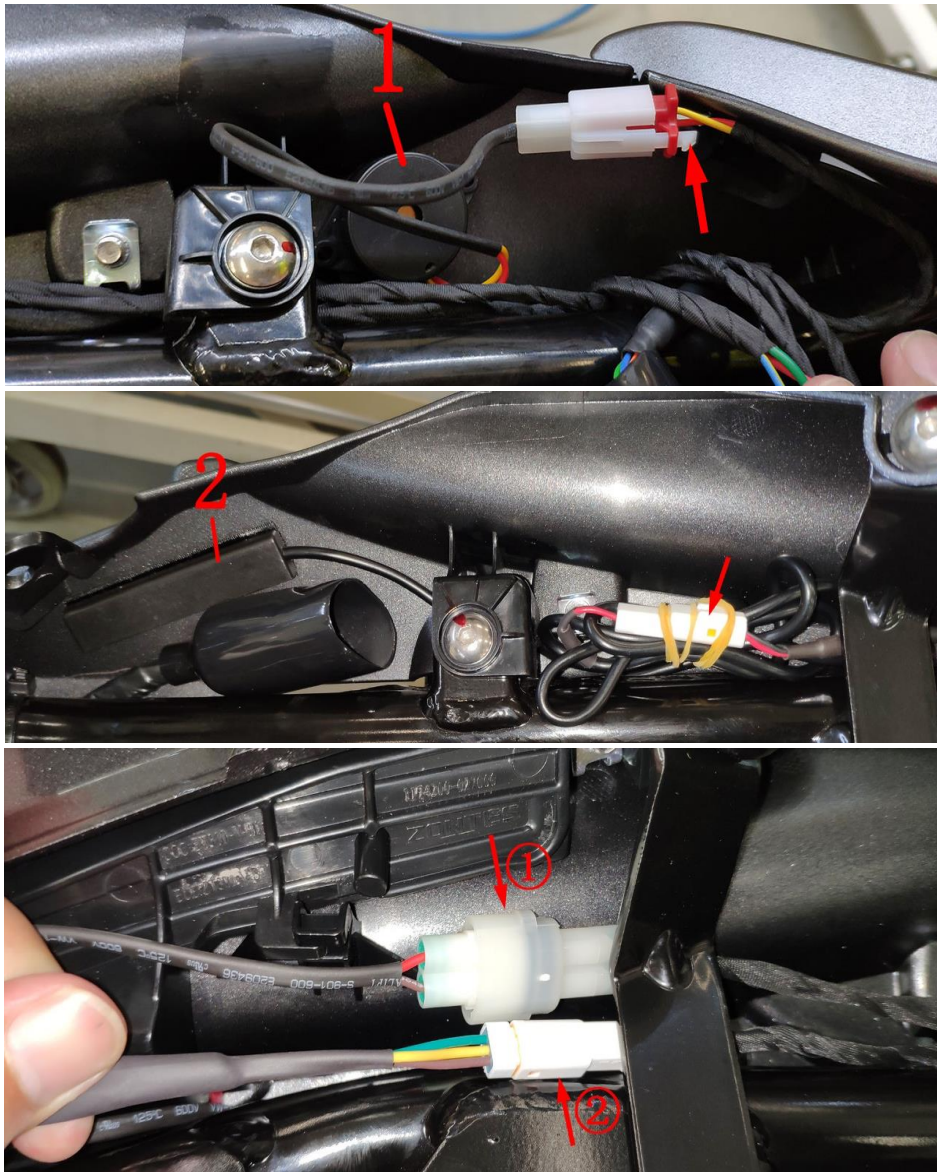

Fig.4 REAR COVER COMPONENT		Tail skirt taillight component 1		CHK	
NO.	PART NO.	PART NAME	QTY	CAUTION	
1	1186800-177000	ZT703-F PKE Buzzer (4KHZ)(after-sale)	1		
2	1184200-053000	ZT310PKE external single antenna	1		

PROCEDURE:

● Buzzer

Find the connector of the buzzer (1) close to the side cover on the front left side of the rear cover, and press the card of the white plug to remove the plug. Move the buzzer after back and forth with a hot air gun or hair dryer with heat.

● PKE antenna

Find the plug of PKE antenna at the front of right rear cover, pull it out and arrange the cable.

The PKE antenna (2) is pasted with the double topping and the double topping on the rear cover. Heat it slightly with a hot air gun, then tear off the double topping and clean up the residue.

The end of the antenna connected to the main beam can be removed from the gap between the frame and the rear decoration cover.

● The tail light plug

① it is not necessary to pull out the cushion lock plug if the cushion lock is not removed.

② is the tail light plug, need to be pulled out first, convenient back to remove the tail skirt components.

CAUTION:

● When heating, it is forbidden to heat at a fixed position all the time, and it is necessary to move the heating back and forth.

● Do not pull the cable directly when unplugging the plug.

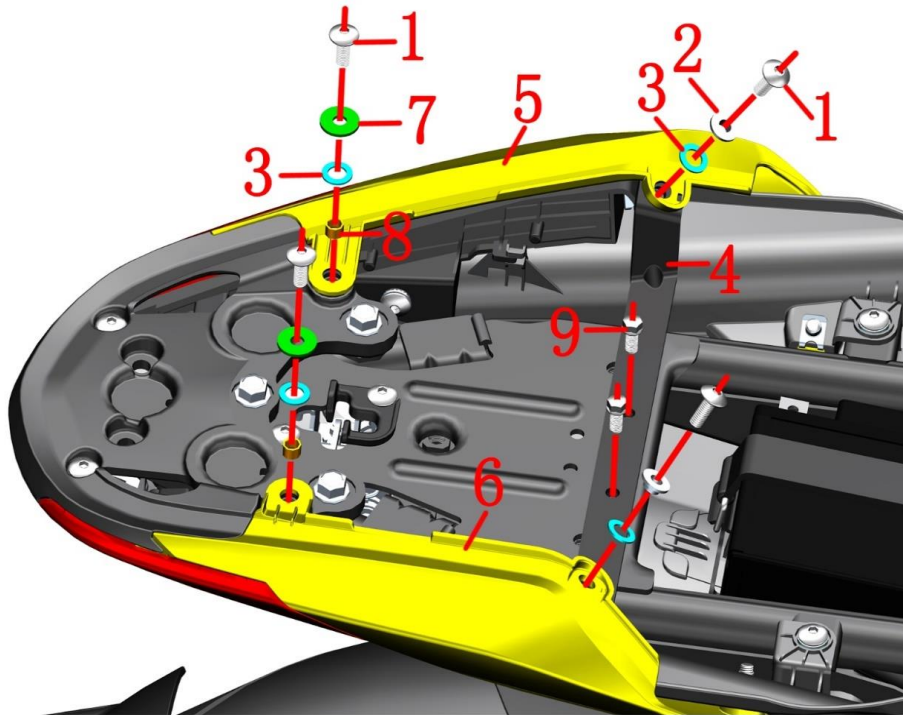

Fig.5 REAR COVER COMPONENT		Tail skirt taillight component 2	CHK	CAUTION
NO.	PART NO.	PART NAME	ADJ	
1	1251100-102000	Non-standard bolt M6×16 (304 stainless steel)	6	
2	1274100-155095	Flanged bushing φ6.2×φ8.4×3.5+φ14×1.5(5 pcs/after-	4	
3	1241200-124021	flanging bushing buffer rubber (φ8.5×φ14×1)(5 pcs/af	6	
4	1274200-138000	ZT310-V Rear cover trim cover holder	1	
5	4044201-290052	Rear cover left trim cover (dark grey with red sticker)	1	red
	4044201-292052	Rear cover left trim cover (dark grey with yellow sticker)		yellow
	4044201-286052	Rear cover left trim cover (dark grey with golden sticker)		black
	4044201-294052	Rear cover left trim cover (dark grey with white sticker)		white
	4044201-288052	Rear cover left trim cover (dark grey with purple sticker)		purple
6	4044201-291052	Rear cover right trim cover (dark grey with red sticker)	1	red
	4044201-293052	Rear cover right trim cover (dark grey with yellow sticker)		yellow
	4044201-287052	Rear cover right trim cover (dark grey with golden sticker)		black
	4044201-295052	Rear cover right trim cover (dark grey with white sticker)		white
	4044201-289052	Rear cover right trim cover (dark grey with purple sticker)		purple
7	1250502-010093	GB96.1φ6 (color zinc)	2	
8	1274100-018000	Anti-hot plate sleeve, muffler	2	
9	1250104-006097	GB16674M6×12 (chrome plating/HH)	2	

PROCEDURE:

●Rear cover trim cover

Remove the bolt (1) on the bottom left side and remove the bushing (2) and cushion rubber (3).

Remove the bolt (1) on the bottom right side and remove the bushing (2) and cushion rubber (3).

Remove the bolt (1) and bolt (9) on the trim cover holder and remove the bushing (2) and cushion rubber (3).

Remove the bolt (1) on the rear trim cover and remove the gasket (7) bushing (3) and cushion rubber (8).

Pull the left trim cover (5) and the right tail trim cover (6) together and remove.

Remove the trim cover bracket (4).

CAUTION:

●The material should be protected during discomponent to prevent scratching the lamp.

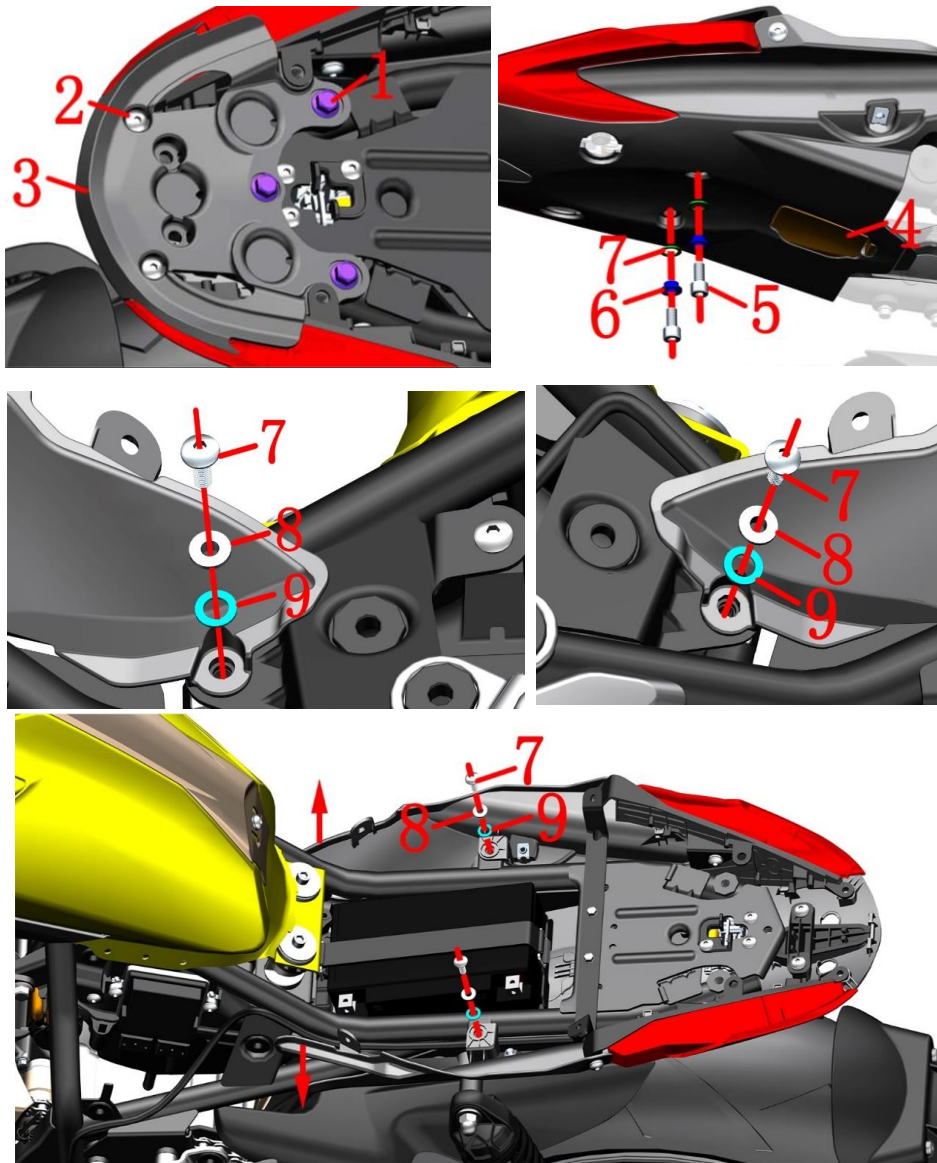

Fig.6 REAR COVER COMPONENT		Tail skirt taillight component 3	CHK	CAUTION
			ADJ	
NO.	PART NO.	PART NAME	QTY	
1	1250105-142093	GB5789M8×20 (color zinc)	3	
2	1251100-101000	Non-standard bolt M6×12 (304 stainless steel)	2	
3	4024200-044052	ZT310-V rear aluminium holder	1	
	4024200-073051	ZT310-V rear aluminum alloy bracket (dark gray matte)		
4	4044201-255051	ZT310-V PKE cover (dark grey)	1	
5	1251100-117093	Non-standard inner hex bolt M8×25 (color zinc)	2	
6	1240300-071000	Flanging bushing rubber (φ11×φ16×1)	2	
7	1251100-102000	Non-standard bolt M6×16 (304 stainless steel)	6	
8	1274100-155095	Flanged bushing φ6.2×φ8.4×3.5+φ14×1.5(5 pcs/after-	4	
9	1241200-124021	flanging bushing buffer rubber (φ8.5×φ14×1)(5 pcs/aff	6	

PROCEDURE:

- Rear aluminum alloy bracket
Remove the bolt (1) and bolt (2); take off the bracket (3).
- Rear cover trim cover
Remove PKE small cover (4) after pressing down.
Remove the two bolts (1) on the bottom , remove the cushion rubber (6).
Remove the bolt (7) on the front right trim cover , remove the bushing (8) and cushion rubber (9).
Remove the bolt (7) on the front left trim cover , remove the bushing (8) and cushion rubber (9).
Remove the bolt (7) on the front middle trim cover , remove the bushing (8) and cushion rubber (9).
Pull out the nail in front of the tail light assembly and the trim cover then remove it.

CAUTION:

- The material should be protected during discomponent to prevent scratching the lamp.
- Never pull the cable directly.

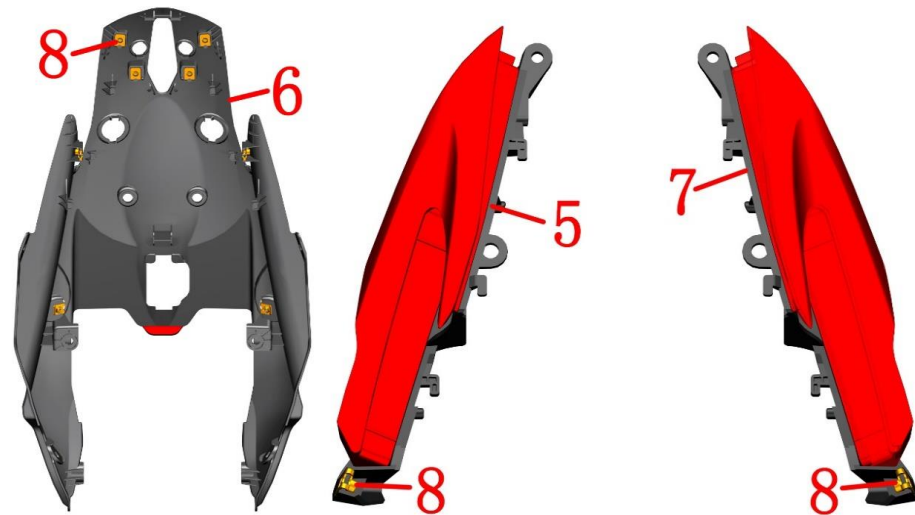
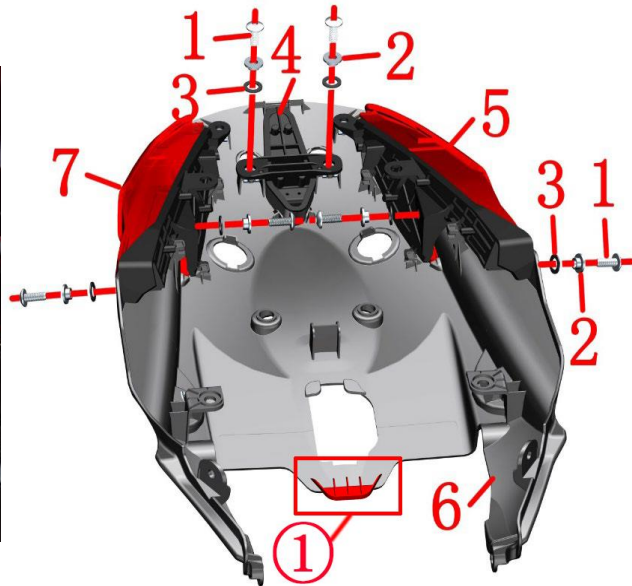

Fig.7 REAR COVER COMPONENT		Tail skirt taillight component 4	CHK	CAUTION
			ADJ	
NO.	PART NO.	PART NAME	QTY	
1	1251100-102000	Non-standard bolt M6×16 (304 stainless steel)	6	
2	1274100-155095	Flanged bushing φ6.2×φ8.4×3.5+φ14×1.5(5 pcs/after-	6	
3	1241200-124021	flanging bushing buffer rubber (φ8.5×φ14×1)(5 pcs/aft	6	
4	1174200-029000	ZT310-V Stop light	1	
5	1174200-027000	ZT310-V rear left light	1	
6	4044201-252051	ZT310-V rear cover dark grey	1	
7	1174200-028000	ZT310-V rear right light	1	
8	1251300-063093	Plywood M6×11×15 (color zinc)	10	

PROCEDURE:

●Rear light

First pull out the plug of the left rear tail lamp (5) and the right rear tail lamp (7).

Remove two bolts (1) of the brake lamp (4), take off the bushing (2) and cushion rubber (3);Pull up the outlet side of brake lamp and remove it.

Remove the bolt (1) on both sides of the left rear lamp (5), remove bushing (2) and cushion rubber (3) ;Pull back the left rear tail light.

Remove the right rear tail lamp (7)as shown above.

Remove from the rear trim cover (6) 8 pieces nuts(8)

Respectively from the left tail lamp (5) and right tail lamp once each took a piece of nut.

CAUTION:

● The material should be protected during discomponent to prevent scratching the lamp.

● Never pull the cable directly.

● As shown at ①, users who have a production date before June 2020 must manually cut the red part of the tail skirt before installation.

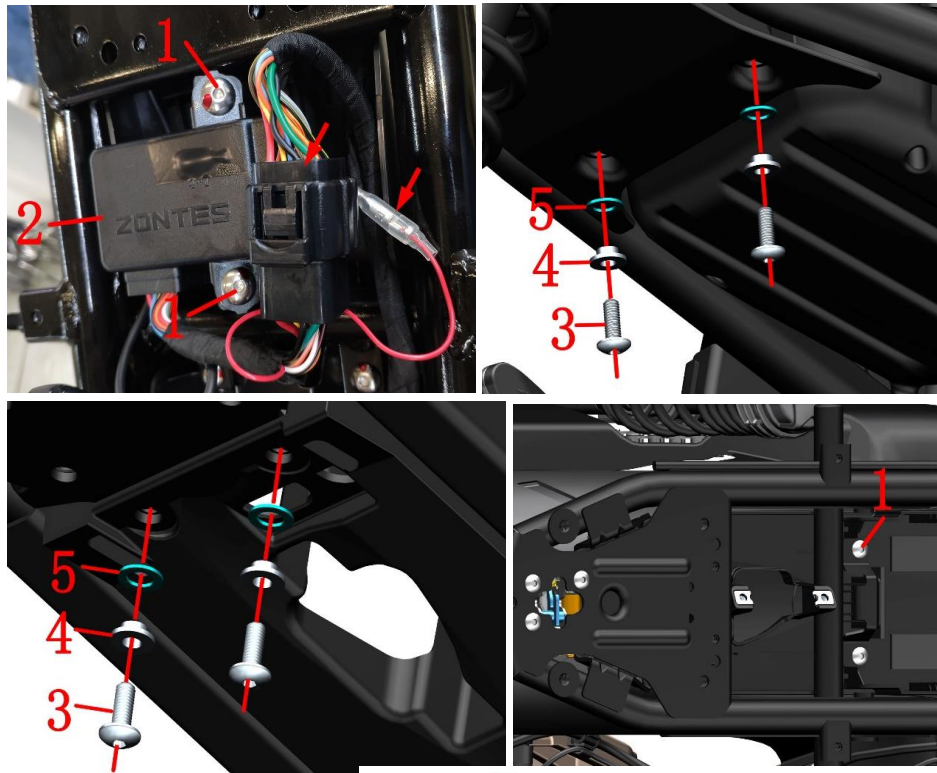

9



Fig.8 REAR COVER COMPONENT		ZT310 -V Electrical device box component	CHK	⚠
			ADJ	
NO.	PART NO.	PART NAME	QTY	CAUTION
1	1251100-101000	Non-standard bolt M6×12 (304 stainless steel)	4	
2		ZT310 PKE controller (single antenna)	1	stop selling
	1184200-137000	ZT310 PKE Assembly (Hand Ring Edition)		
3	1251100-102000	Non-standard bolt M6×16 (304 stainless steel)	4	
4	1274100-155095	Flanged bushing φ6.2×φ8.4×3.5+φ14×1.5(5 pcs/after-	4	
5	1241200-124021	flanging bushing buffer rubber (φ8.5×φ14×1)(5 pcs/af	4	
6	1224200-111000	ZT310 -V Electrical device box	1	
7	1251300-063093	plywood M6×11×15 (color zinc)	4	
8	1184100-080000	Fuze wire (15A)	1	【1】
9	1184200-043000	ZT310 PKE key decorative part	1	
10	1184200-244000	ZT310 univrsal fuse (15A small)(5 pcs/after-sale)	2	【2】
11	1244200-204000	ZT310 induction key rubber ring(after-sale)	1	

PROCEDURE:

- PKE controller
Unplug the PKE controller (2) cable connectors , remove 2 pcs bolts(1), and then take off the PKE controller.
- Electrical device box component
Remove the bolt (3) under the front of the electrical box and remove the bushing (4) and cushion rubber (5).
Remove the bolts (3) under the rear of the electrical box and remove the bushing (4) and cushion rubber (5).
Hold the electrical component box assembly and remove the two upper bolts (1).
Remove the electrical component box assembly from the frame. Remove the 4 nuts (7).
- Fuses
Unplug the fuse (8) or (10) and check if it is blown. If it has blown, replace the fuse of the same specification.
The single-antenna version of PKE assembly is a KST medium-sized 15A fuse. The bracelet version of the PKE assembly uses 2 small 15A fuses.

CAUTION:

- When inserting or removing the fuse, pay attention to the vertical alignment and then disassemble it. Do not bend it. Use a qualified fuse.PKE cables need to be protected. Non-professionals are strictly prohibited from dismantling the PKE system components, as this may cause permanent damage.Please refer to the driving manual for details on the use of PKE.
- PKE key shell (containing key glue+key ring) just for after-sale to change the shell,no internal electrical appliances.
- 【1】 for single antenna after-sale; 【2】 for hand ring edition after-sale.

Fig.9 REAR COVER COMPONENT	External battery start PKE system	CHK	
		ADJ	

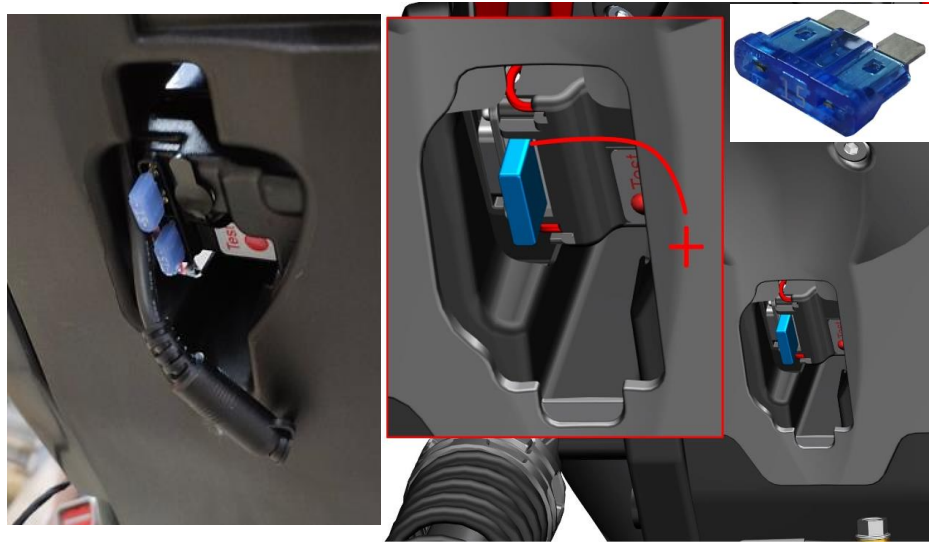

PROCEDURE:

- Emergency handling method after the battery is destroyed or the battery is exhausted for too long:
 - Remove the PKE cover and pull out the charging port. Unplug the charger plug and insert the special lithium battery charger for manual charging. Pay attention to fire prevention and ventilation during charging. Pay attention to the charging time and do not overcharge
 - Find a 15A fuse and wind a wire around any one of the fuses as shown in the left side.
 - Remove the lower cover of the electrical device box; The old PKE leads had to be connected to a slot near the end. The bracelet style is attached to the last slot near the first fuse
 - Find a battery with sufficient power and connect the previously made wire to the positive side of the battery.
 - Find one end of the wire attached to the frame (the bolt is directly connected to the frame) and the other end to the negative pole of the battery.
 - After connecting the wires, check that the wires are fixed and short press the unlock button " " turn on the PKE system. Disable pressing the ignition button at this time. 



CAUTION:

- The wire must be connected to the right slot in the forward direction of the finished motorcycle.
- When connecting the battery, always connect the positive electrode first and then connect the negative electrode. When disassembling, disassemble the negative electrode and then remove the positive electrode. Be sure to pay attention to the order of discomponent.
- The negative pole must be connected with the frame and can be connected to the bolt head directly connected to the frame.



Single antenna

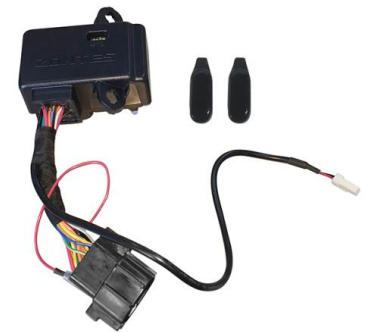

Hand Ring Edition

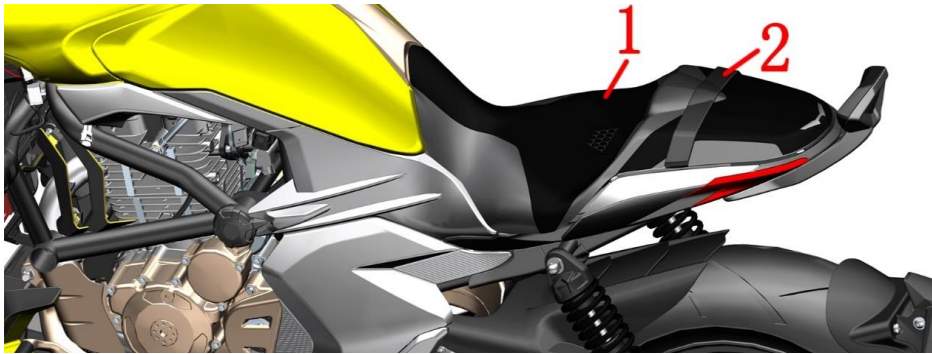

FIG.1 CUSHION COMPONENT		Cushion component	CHK	CAUTION
NO.	PART NO.	PART NAME	ADJ	
1	1200100-464000	ZT310-V seat cushion (2021 models)	1	【1】
2	1010502-012000	ZT310-V Seat belt	1	
3	1244200-091000	ZT310-V Seat front round gum cushion	2	
4	1244100-024000	ZT250-S Cushion front rubber	2	
5	1244100-022000	ZT250-S Cushion rubber	4	
6	1244100-025000	ZT250-S Cushion round rubber	5	
7	1250303-040093	GB6177.1M6 (environmental color)(5 pcs/after-sale)	2	

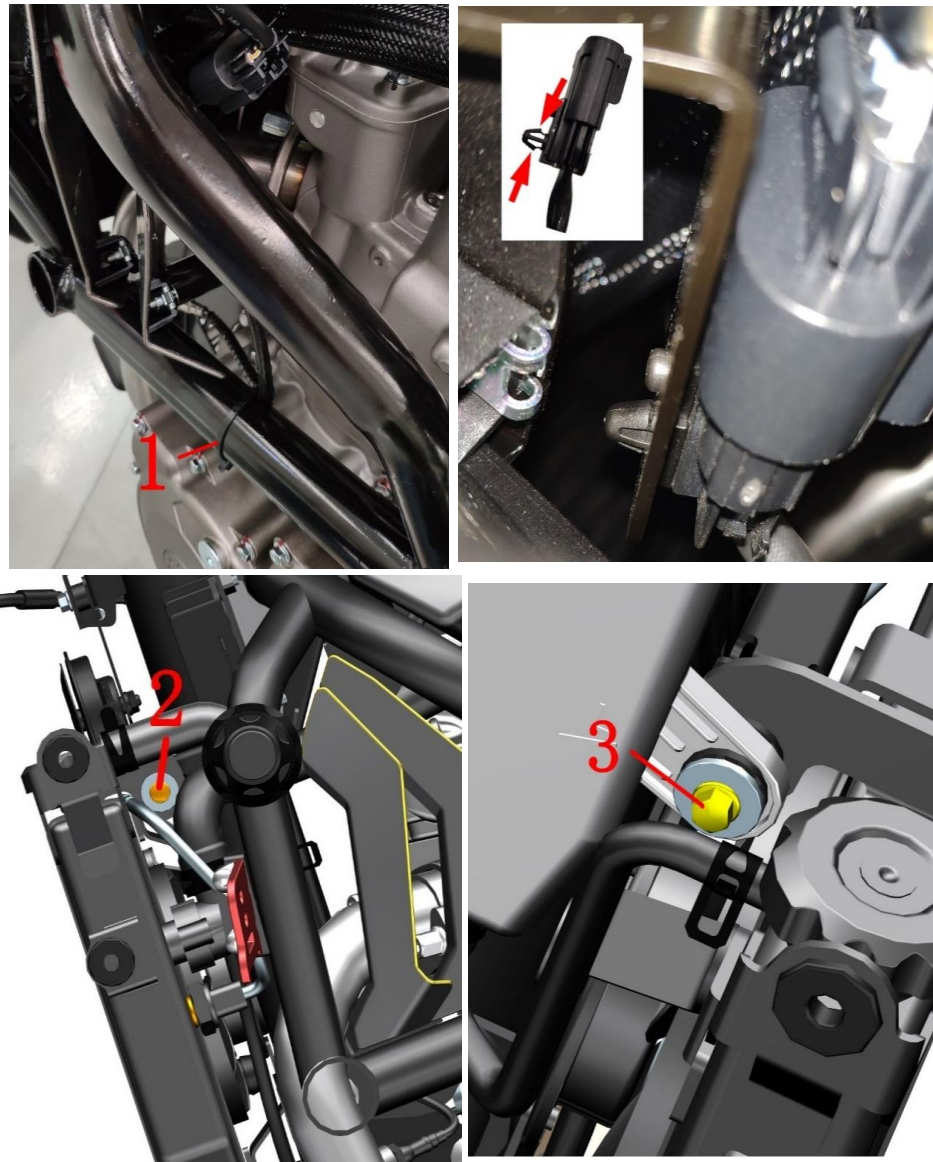

FIG.1 MUFFLER COMPONENT		Muffler component 1	CHK	⚠
NO.	PART NO.	PART NAME	ADJ	
1	1226000-218000	Grade 0 flame retardant tie (black 3.6×295)(5 pcs/after-	1	
2	1251112-002093	M6×30 Hexagon flange bolts (color zinc)	1	
3	1251112-003093	M6×45 Hex flange surface 9.8 bolt (color zinc)	1	

PROCEDURE:

● Muffler assembly

Remove the shroud assembly according to the step of "lower shroud assembly 1".

Referring to the steps in "Radiator Decorative Cover Part 1", remove the radiator decorative cover component first.

Cut the tie belt (1).

Use pointed tongs to penetrate the gap of the engine decorative cover, slightly clamp the limit protrusion on the buckle of the oxygen sensor, and pull the plug off the guard bar. Separate the oxygen sensor plug from the main harness.

Remove the left main water tank bolt (2).

Remove the right main water tank bolt (3).

Pull the radiator assembly open to facilitate subsequent removal of muffler nuts.

CAUTION:

- The material should be protected during disassembly to prevent damage to the paint.
- The muffler should be completely cooled before it is disassembled.

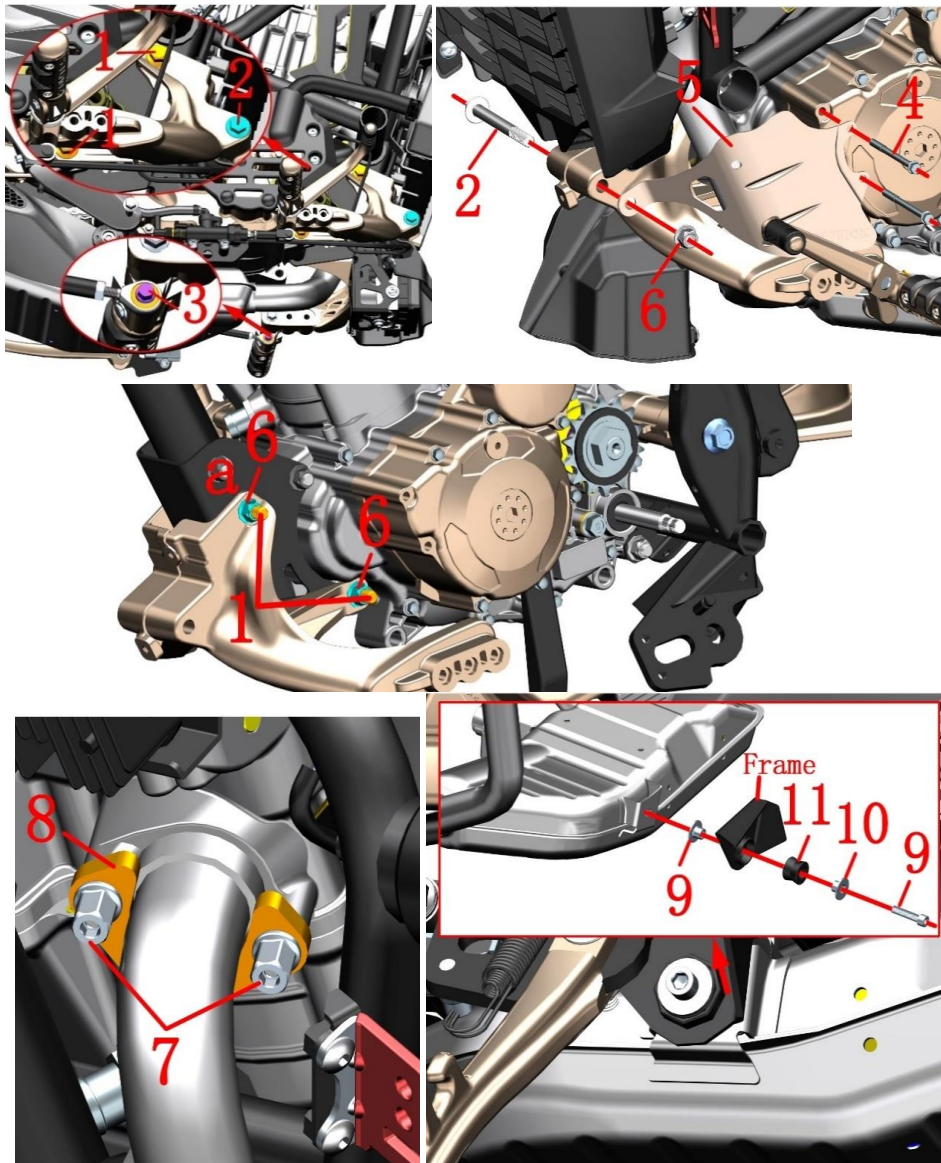

FIG.2MUFFLER COMPONENT		Muffler component 2	CHK	REMARKS
NO.	PART NO.	PART NAME	ADJ	
1	1251100-137000	non-standard boltM10×1.5×100(Dacromet)	2	
2	1251100-135000	non-standard bolt M10×1.5×95(Dacromet)	1	
3	1251100-061093	M6×22 Hex flange bolt thread level 8.8 (color zinc))	1	
4	1251112-003093	M6×45 Hex flange surface 9.8 bolt (color zinc)	2	10N.m
5	4024200-058035	ZT310-V Muffler Left Anti-scalding Plate (Titanium)	1	
6	1251300-057093	non-standard nuts M10×1.5 (color zinc)	3	65±5N.m
7	1251300-058093	Inner hexagonal nut M8 (color Zinc)	2	
8	1020265-155000	ZT250-S muffler flange (outsourcing)	1	
9	1250205-023000	GB70.1 inner hexagonal M8X35 (army green)	1	
10	1274100-068095	ZT310 Muffler flanging bushing	2	
11	1244100-064000	ZT310 Muffler rubber	1	

PROCEDURE:

- Front-left pedal bracket assembly
 - Grasp the anti-scalding board and remove two bolts.
 - Fix the head of the bolt with sleeve, remove the nut and remove the anti-scalding board.
 - The gap between the left radiator and the left pedal bracket extends into the nut (1) which is fixed by the 14
 - Remove the bolt on the back of the shifter pedal rocker arm.
 - Fix the head of the bottom bolt, remove the nut with sleeve on the left side and remove the left foot bracket assembly; the bolt can not be removed.
- The front of the muffler
 - Push the radiator assembly forward to reveal two nuts and remove them.
 - Remove the muffler flange.
- Muffler assembly
 - Remove the bolt at the installation point of the left muffler and remove the outer bushing. Buffer glue and bushing near muffler hanging ear need to be removed before the muffler assembly can be removed.

CAUTION:

- The muffler should be completely cooled before it is disassembled.
- Early production does not contain muffler left ironing plate, can be installed

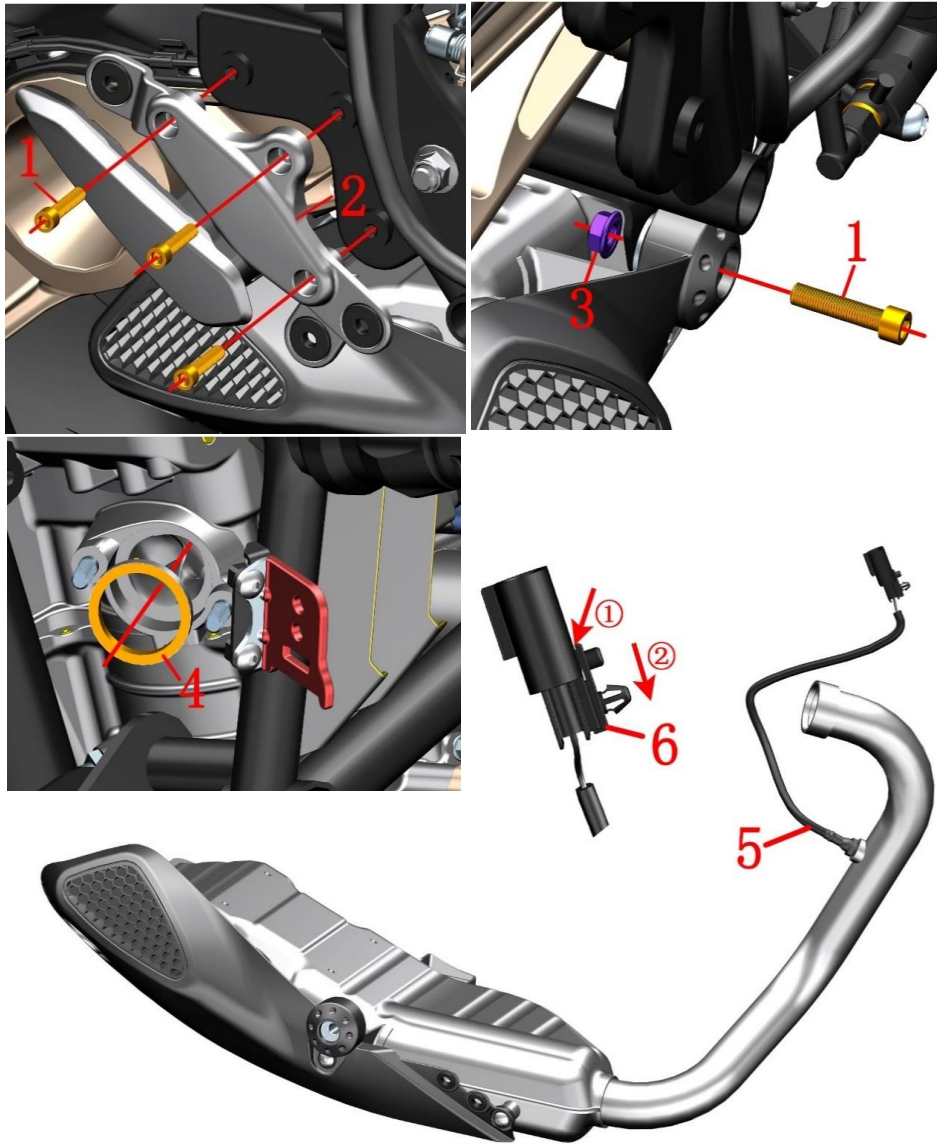

FIG.3MUFFLER COMPONENT		Muffler component3	CHK	REMARKS
NO.	PART NO.	PART NAME	ADJ	
1	1250205-023000	GB70.1 inner hexagonal M8X35 (army green)	4	
2	1274200-226000	ZT310-V Rear Right Foot Support Assembly	1	
3	1250303-011093	GB6177.1M8(environmental color)	1	
4	1070100-133000	engine exhaust outlet seal	1	
5	1050953-008000	OSM planar oxygen sensor 25322728	1	Delphi
	1050954-026000	LSF oxygen sensor		Bosch
6	1224100-013000	ZT250-S Oxygen sensor fixing buckle	1	
	1224200-008000	ZT310-R cable clip		

PROCEDURE:

- Rear right pedal bracket assembly
Remove the right side cover according to the step of removing the side cover.
Remove three bolts (1) and remove the right rear pedal bracket assembly (2).
- Muffler assembly
Put the plum wrench into the gap and fix the nut, hold the muffler assembly, and remove the bolt.
Remove the muffler assembly from the frame. Be careful not to pull the oxygen sensor cable.
Remove the sealing gasket from the exhaust port (4). It is recommended to replace the new sealing gasket after disassembling and assembling the muffler each time.
- Oxygen sensor
Insert the small screwdriver into (1) pry the fixed button open, and push the arrow (2) in the direction indicated by the arrow (2) to remove it from the oxygen sensor wire adapter. Remove the oxygen sensor with an open wrench.

CAUTION:

- The muffler should be completely cooled before it is disassembled.

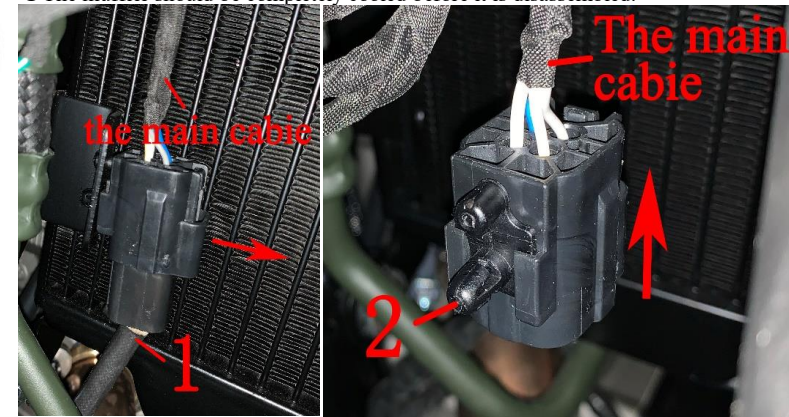

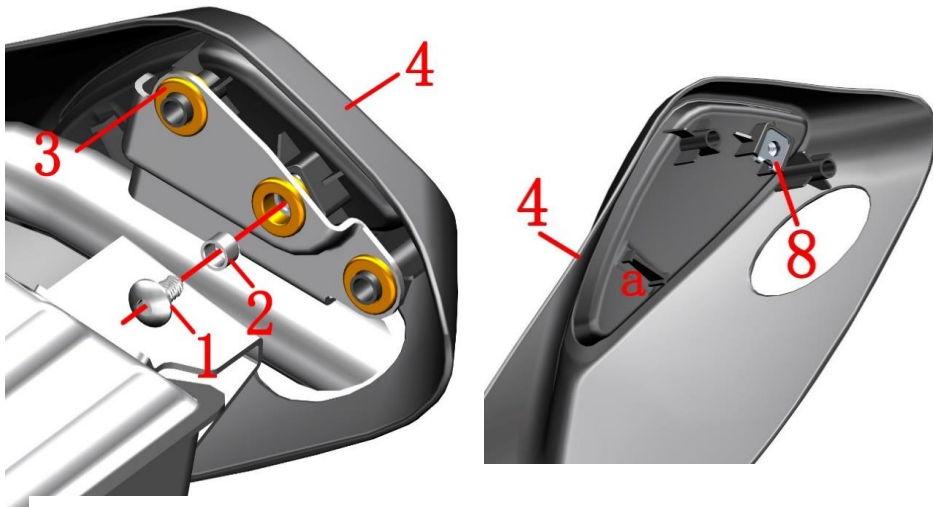
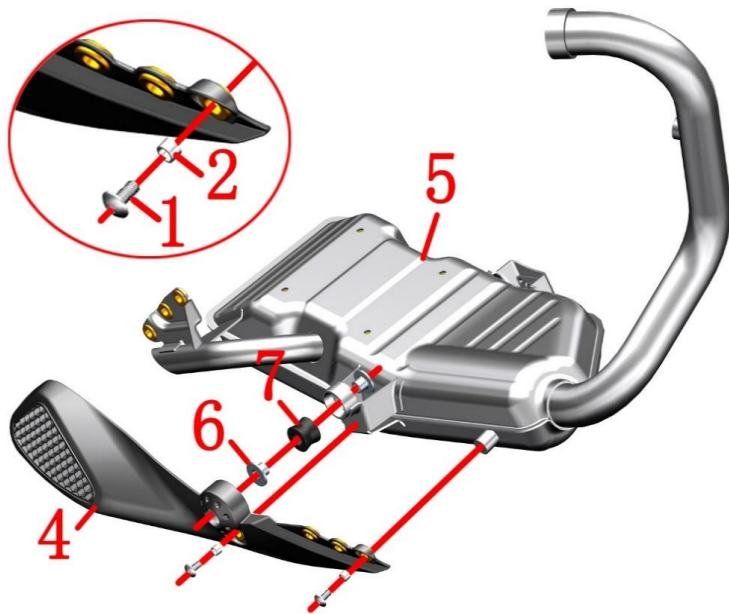

FIG.4 MUFFLER COMPONENT		Muffler component4	CHK	REMARKS
NO.	PART NO.	PART NAME	ADJ	
1	1251100-101000	non-standard bolt M6×12 (304 stainless steel)	3	
2	1274100-018000	anti-hot plate sleeve, muffler	3	
3	1244100-017000	muffler hot plate rubber buffer	7	
4	4044201-243051	ZT310-V Muffler Decorative Cover (Deep Gray Dumb	1	
5	1124200-007000	ZT310-V Muffler (Self-made/China IV)	1	Delphi
	1124200-018000	ZT310-V Muffler (Homemade/China IV/Bosch EFI version)		Bosch
6	1274100-068095	ZT310 Muffler flanging bushing	2	
7	1244100-064000	ZT310 Muffler rubber	1	
8	1251300-063093	plywood M6×11×15 (color zinc)	1	



PROCEDURE:

●Decorative cover

Remove the bolt (1) at the back of the decorative cover and remove the bushing (2).

Remove the two bolts (1) of the side cover and remove the bushing (2).

Remove the decorative cover from the muffler.

Remove four cushioning glues from the decorative cover.

Turn over to the back and remove the splint nut.

●Muffler

Remove three cushioning glues from the rear of the muffler.

Remove two bushes and one cushioning glue from the middle of the right muffler.

CAUTION:

●Prevent foreign matter from entering the muffler or engine interior.

●If bushing is not desirable, the decorative cover can be removed before removal.

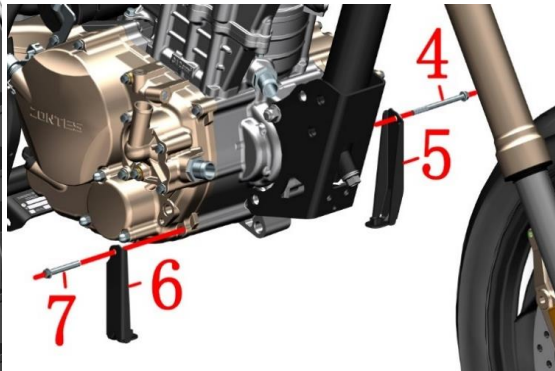
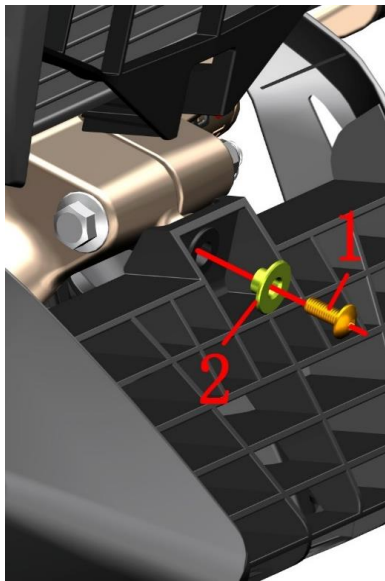
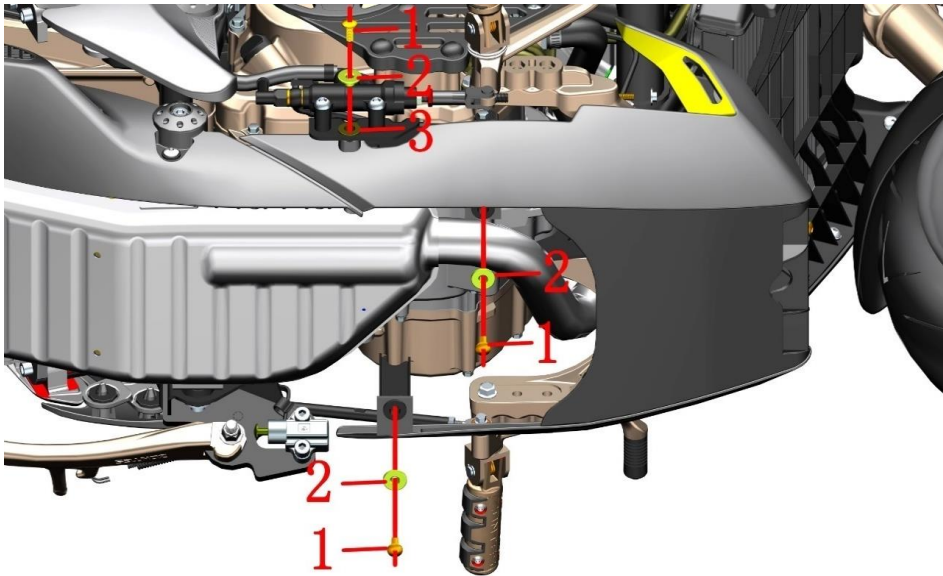

FIG.1 LOWER SHROUD COMPONENT		Lower shroud component-1	CHK	⚠
NO.	PART NO.	PART NAME	ADJ	
1	1251100-102000	Non-standard bolt M6×16 (304 stainless steel)	4	
2	1274101-015000	ZT250-S flanging sleeve(φ6.4×φ9×6+φ20×2)(5 pcs/af)	4	
3	1244100-137000	ZT250-S Flanging bushing buffer(5 pcs/after-sale)	1	
4	1251112-005093	M6×75 Hexagonal flange bolt (color zinc)	1	12±1.5N.m
5	1274200-130000	ZT310—V left support of lower wind deflector	1	
6	1274200-131000	ZT310—V right support of lower wind deflector	1	
7	1251112-003093	M6×45 Hex flange surface 9.8 bolts (color zinc)	1	12±1.5N.m

PROCEDURE:

● Lower shroud assembly

Raise the platform of the motorcycle and remove the plate brake pump after the bolt (1), take off the lining.

Remove the bottom left and right side of the bolt (1), remove the liner (2).

After supporting the cowl assembly, remove the front center bolt (1) and remove the liner (2).

Remove the guide housing assembly and place it in place. Take buffer glue as needed.

● Lower shroud bracket

Remove the bolt(4) with the sleeve and remove the left shroud bracket(5).

Remove the bolt(7) with the sleeve and remove the right shroud bracket(6).

CAUTION:

- The motorcycle support should be fixed during disassembly to prevent accidents caused by incline.
- The shroud should be supported during disassembly to prevent fracture due to uneven force.
- The bolts(4) and (7) must meet the standard torque and must be coated with a thread tightening glue.

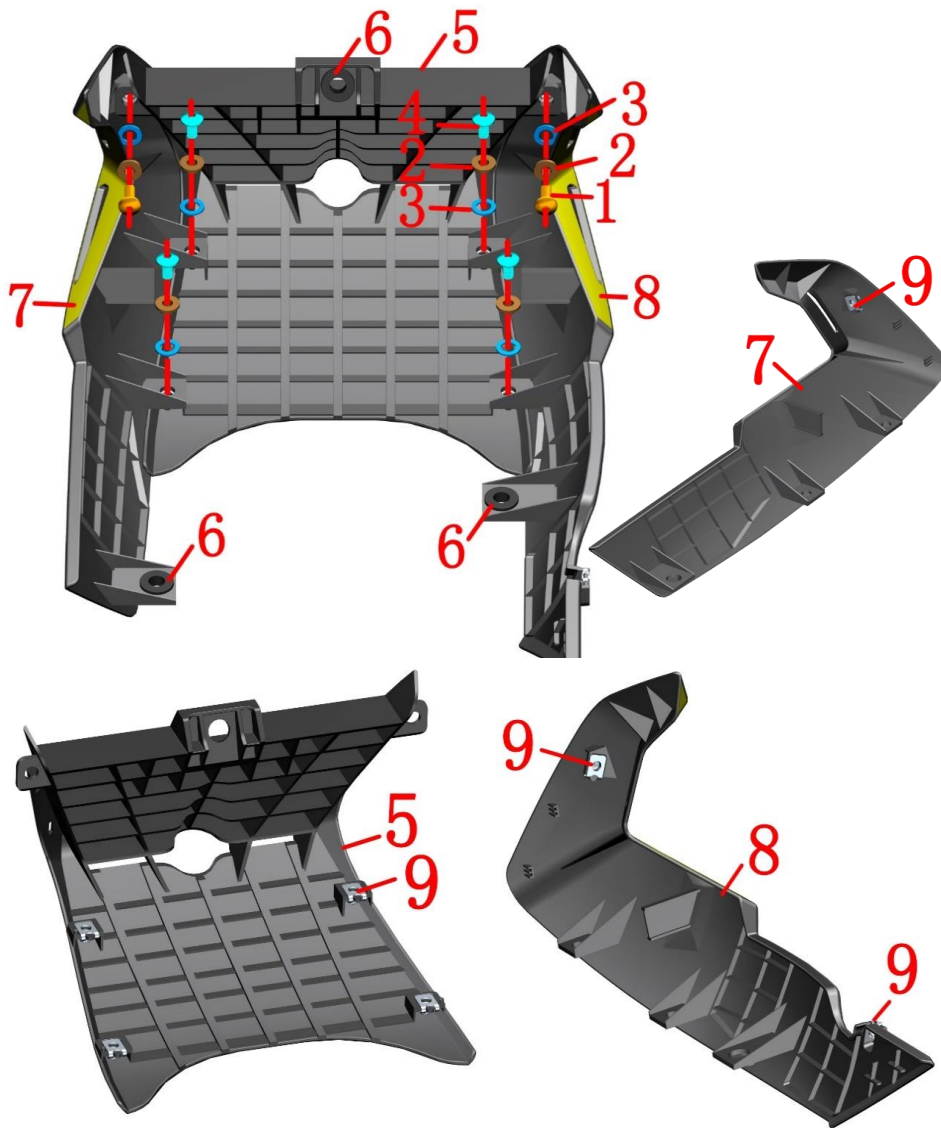

FIG.2 LOWER SHROUD COMPONENT		Lower shroud component 2	CHK	REMARKS
NO.	PART NO.	PART NAME	ADJ	
1	1251100-102000	Non-standard bolt M6×16 (304 stainless steel)	2	
2	1274100-155095	Flanged bushing $\phi 6.2 \times \phi 8.4 \times 3.5 + \phi 14 \times 1.5$ (5 pcs/after-	6	
3	1241200-124021	flanging bushing buffer rubber ($\phi 8.5 \times \phi 14 \times 1$) (5 pcs/aft	6	
4	1251100-101000	Non-standard bolt M6×12 (304 stainless steel)	4	
5	1224200-108000	ZT310—V middle part of lower wind deflector	1	
6	1244100-137000	ZT250-S Flanging bushing buffer (5 pcs/after-sale)	3	
7	4044201-241051	Left support of lower wind deflector (grey matt)	1	black
	4044201-275051	Left support of lower wind deflector (bright red)		red
	4044201-269051	Left support of lower wind deflector (bright yellow)		yellow
	4044201-267051	Left support of lower wind deflector (bright purple)		purple
	4044201-283001	Left support of lower wind deflector (bright white)		white
8	4044201-242051	Right support of lower wind deflector (grey matt)	1	black
	4044201-276051	Right support of lower wind deflector (bright red)		red
	4044201-270051	Right support of lower wind deflector (bright yellow)		yellow
	4044201-268051	Right support of lower wind deflector (bright purple)		purple
	4044201-282001	Right support of lower wind deflector (bright white)		white
9	1251300-063093	Plywood M6×11×15 (environmental color)	7	

PROCEDURE:

● Lower shroud assembly

Remove 2 bolts (1) and four bolts (4), remove the flange bush (2) and pad (3).

Remove 3 pieces of buffer jelly (6).

Separate the lower shroud assembly into three parts.

● Shroud left part

Remove the plywood nut (9) from the left part of the shroud (5).

● Shroud right part

Remove the plywood nut (9) from the right part of the shroud (8).

● Shroud middle part

Remove the plywood nut (4) from the middle part of the shroud (5).

CAUTION:

● The shroud should be well protected during disassembly to prevent breakage or paint scratches caused by uneven force.