

升 ZONTES

# ZT125/155/200-C (EURO V)



2024/4/22

# Contents

## Table of Contents

	Pages
<b>0 Table of Contents.....</b>	<b>1</b>
<b>1 FRAME&amp;ELECTRONIC COMPONENT</b>	
1.1 Electrical device component-1..... horn,ignition coil	6
1.2 Electrical device component-2..... Front electrical device box, frame front decoration cover	7
1.3 Frame plastic parts..... Line clamp, side cover round glue, fuel tank liner limit glue	8
1.4 Directional column component..... Lower plate component	9
1.5 Frame, side bracket..... Frame, side bracket,Flameout switch	10
<b>2 FRAME &amp; ENGINE COMBINATION</b>	
2.1 Frame & engine combination 1(125/155CC).....	11
2.2 Frame & engine combination 2(125/155CC).....	12
2.3 Frame & engine combination 1(200CC).....	13
2.4 Frame & engine combination 2(200CC).....	14
<b>3 INTAKE SYSTEM COMPONENT</b>	
3.1 Air filter component..... Disassemble air filter,ECU,Carbon canister	15
3.2 Throttle valve body component.....	16
3.3 Replace air filter element.....	17
<b>4 REAR WHELL COMPONENT</b>	
4.1 Rear mud board 1.....	18
4.2 Rear mud board 2.....	19
4.3 Rear shock absorpction.....	20
4.4 Rear wheel component 1..... Disassemble the rear rim component, sprocket seat, sprocket	21
4.5 Rear wheel component 2.....	22

# Contents

Table of Contents	Pages
Disassembled rear rim component	
4.6 Rear fork component.....	23
Disassembled rear fork component	
4.7 Replace the rear brake pads.....	24
4.8 Rear brake main pump adds brake fluid.....	25
<b>5 PEDAL COMPONENT</b>	
5.1 Adjust the hight of foot pedal	26
Shift lever, brake pedal height adjustment	
5.2 Front right foot pedal assembly position adjustment.....	27
5.3 Front left foot pedal assembly position adjustment.....	28
5.4 Right footrest component.....	29
5.5 Left footrest component.....	30
5.6 Rear footrest component.....	31
<b>6 COOLING SYSTEM COMPONENT</b>	
6.1 Change the oil and the oil filter.....	32
6.2 Add coolant.....	33
6.3 Change coolant.....	34
6.4 Water tank component(125/155CC).....	35
6.5 Water tank component(200CC).....	36
<b>7 FRONT FORK COMPONENT</b>	
7.1 Throttle/clutch cable clearance adjustment, light height adjustment.....	37
7.2 Replacement clutch cable.....	38
7.3 Replace the throttle line.....	39
7.4 Steering adjustment.....	40
7.5 Right hand component.....	41
Disassemble right hand component	
7.6 Add brake fluid, rocker adjustment.....	42
7.7 Replace the front brake pads.....	43
7.8 Front wheel component.....	44
Disassemble the front wheel, front disc brake disc, front axle component	
7.9 Front mud board & wheel speed sensor component 1.....	45

# Contents

Table of Contents	Pages
Disassemble front wheel speed sensor component, front mud plate component	
7.10 Left hand component.....	46
Disassemble left hand component	
7.11 Direction handle pressure block assembly.....	47
Direction handle assembly	
7.12 Upper connction board Instrumentation assembly.....	48
Upper connction board Components、faucet lock	
7.13 Upper connction board、direction handlebar pad assembly.....	49
Upper connction board、direction handlebar pad assembly	
7.14 Head assembly 1.....	50
Headlight assembly, front shock absorber	
7.15 Head assembly 2.....	51
Disassembling the headlight assembly	
7.16 ABS brake system 1.....	52
Releasing brake fluid、tool box	
7.17 ABS brake system 2.....	53
Disassemble the hydraulic control unit、FMC-HU、FC-HU	
7.18 ABS brake system 3.....	54
RMC-HU、rear brake mame pump	
7.19 ABS brake system 4.....	55
RC-HU、wheel speed sensor、rear disc brake caliper	
<b>8 SURROUNDING COMPONENT</b>	
8.1 Decorative covers the upper part component.....	56
8.2 Decorative covers the lower part component.....	57
<b>9 FUEL TANK COMPONENT</b>	
9.1 Fuel tank component1.....	59
9.2 Fuel tank component2.....	59
<b>10 SIDE COVER COMPONENT</b>	
10.1 Side cover componen.....	60
Decompose side cover component, charging port holder	

# Contents

Table of Contents	Pages
<b>11 Rear Electrical device box component</b>	
11.1 Battery component..... Disassemble battery ,battery cover,start relay	61
11.2 Rear Electrical device box component 1..... Disassemble PKE,antenna	62
11.3 Rear Electrical device box component 2..... Disassemble electrical device box,battery bracket	63
<b>12 CUSHION COMPONENT</b>	
12.1 Cushion.....	64
<b>13 MUFFLER COMPONENT</b>	
13.1 Muffler component 1.....	65
13.2 Muffler component 2 (Euro V) .....	66
13.3 Muffler component 2 (Euro V+) .....	67

# Contents

Table of Contents

Pages

Swell nail description

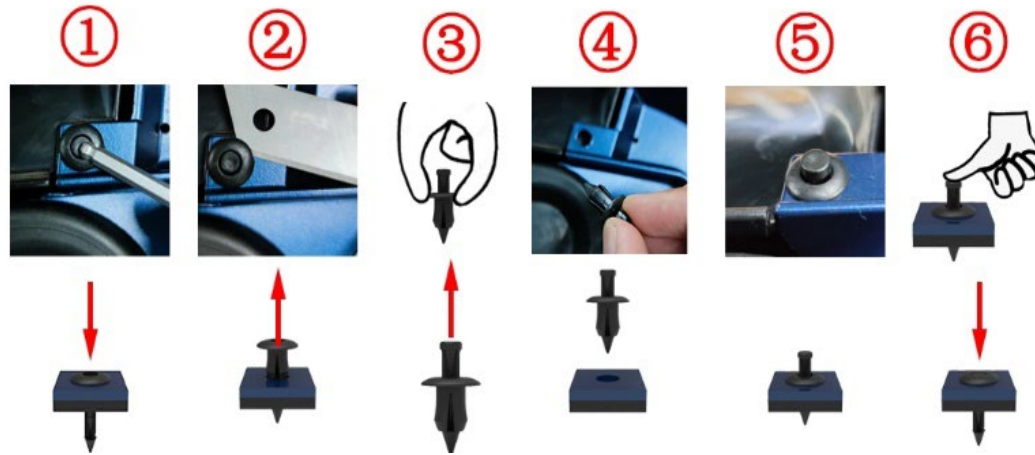

- ① Press down the center cylinder with 4# inner hexagon or other tools, you can hear a sound or the center cylinder moves axially by 2mm;
- ② Pry open the gap with a blade, nail or carving knife, etc. and remove it; if space permits, you can reach it Push out from the back;
- ③ Pinch the outer ring with two fingers, and push the center cylinder up to the initial position;
- ④ Pinch the center cylinder with two fingers to install the swell nails to the installation position;
- ⑤ The outer ring is attached to the connected parts; if not attached Check whether it is misaligned;
- ⑥ Press the center cylinder with your fingers or other tools, and you can hear a sound or the top of the center cylinder is almost flush with the top surface of the outer ring, indicating that the assembly is in place.

All the information, illustrations and photographs collected in this manual are compiled according to the latest products. However, there may be some inconsistencies between your motorcycle and this manual due to the continuous improvement of the product and other changes. For colors or upgrades, please refer to the part codes on the official website. This manual will not be listed in detail; If the part names in this manual are inconsistent with the official website, the official website shall prevail. This manual is compiled on the basis of the Chinese version of KD150-C version. The export version is different from the Chinese version with only a few parts, such as decals, ECU version, muffler catalyst, etc. Although the status of such parts are different, the disassembly method is the same, so refer to the Chinese manual.

©Guangdong Tayo Motorcycle Technology Co.

Ltd All rights reserved

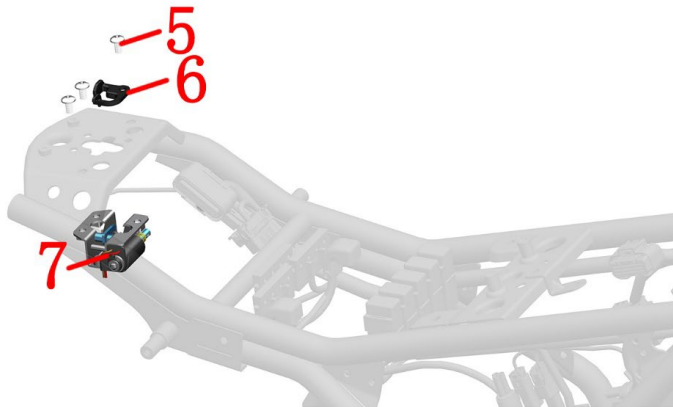
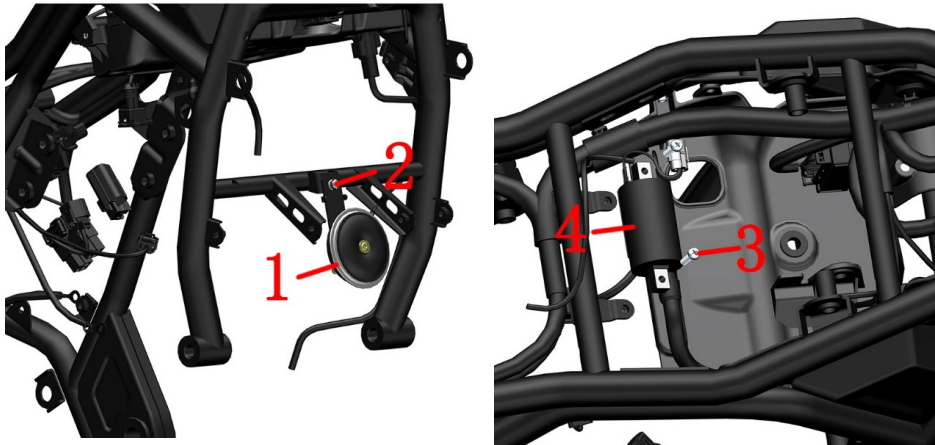

Fig.1 FRAME&ELECTRONIC COMPONENT		Electronic parts COMPONENT 1	CHK	⚠
			ADJ	
NO.	PART NO.	PART NAME	QTY	CAUTION
1	1184200-004000	ZT310 horn	1	
2	1250104-006097	GB16674M6×12 (chromed/HH)	1	
3	1250201-032093	GB818M5×16 (environmental color)	2	
4	1186200-014000	ZT310T-M EFI ignition coil (pedal with thread)	1	125/155CC
	1186500-007000	KD200 electric jet ignition coil		200CC
5	1251100-101000	Non-standard bolt M6×12 (304 stainless steel)	3	
6	1224200-205000	ZT310 electronic cushion lock block	1	
7	1274100-058000	ZT310 Electric seat lock	1	

## PROCEDURE:

## ●Horn

Take off the plug of horn, take the horn(1) by one hand use 8# sleeve remove bolts (2) by another hand, then take off the horn(1).

## ●Ignition coil

Take off the plug of the ignition coil. Remove the crosshead bolts(3) with a cross screwdriver and remove the ignition coil(4).

## ●Seat lock

Find and take off the plug of the seat lock .Using 4# inner hexagon remove 3pcs bolts(5), then take off seat lock(7) and electric seat lock guide block(6).

●Main harness Different plug-in methods are different, please unplug all the electrical components connected to the main thread according to the actual operation. It needs to use a word screwdriver, forceps, scissors and other tools to assist.

## CAUTION:

●When Take off the plug can't drag any cable.

●In order to avoid the improper contact of the bending electrical parts, please pay attention to the direction and angle of force when plugging the electrical parts, so as to avoid the improper contact of the bending electrical parts. No violent operation.

●The location or number of ties may vary from batch to batch, so you need to disassemble them according to the actual situation, and this manual only lists some of the tie locations.

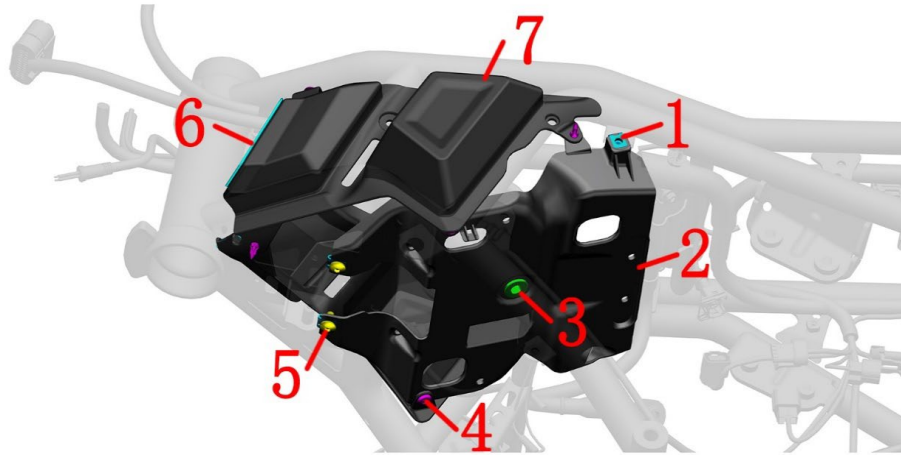
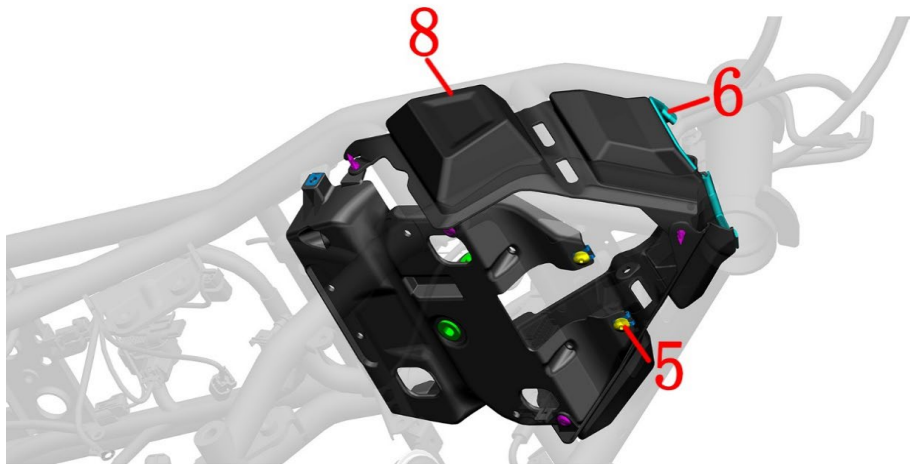

Fig.2 FRAME&ELECTRONIC COMPONENT		Electronic parts COMPONENT 2		CHK	
				ADJ	
NO.	PART NO.	PART NAME	QTY	CAUTION	
1	1251300-063093	Plywood M6×11×15(color Zinc)	4		
2	1226500-004000	KD200-C front electrical device box	1		
3	1244100-004000	ZT250-S Flanging bushing buffer	2		
4	1224100-010000	ZT250-S swell nail	5		
5	1251100-101000	Non-standard bolt M6×12 (304 stainless steel)	2		
6	1240300-021000	HJ125-6 pod glass strip (1.5m)	1		
7	1226500-020000	KD200-C left front decorative cover	1		
8	1226500-021000	KD200-C right front decorative cover	1		

**PROCEDURE:**● **Front electrical device box**

It is necessary to remove the engine, fluid control unit, flasher, carbon canister, etc. first.

Remove the bottom bolts (5) with a 4# hex, and remove the 7 pieces of swell nails (4).

Remove the electronic parts component from the frame, and remove the two pieces of Flanging bushing buffer (3) and the 4 pieces of plywood (1).

● **Front decorative cover**

Remove the left front and right front decorative cover components from the frame.

Remove the pod glass strip (6) from the front of the decorative cover respectively.

**CAUTION:**

● This manual only roughly explains the disassembly steps, and replacing the front decorative cover and front electrical device box is difficult, so it is recommended to go to a qualified aftermarket store for repairs.



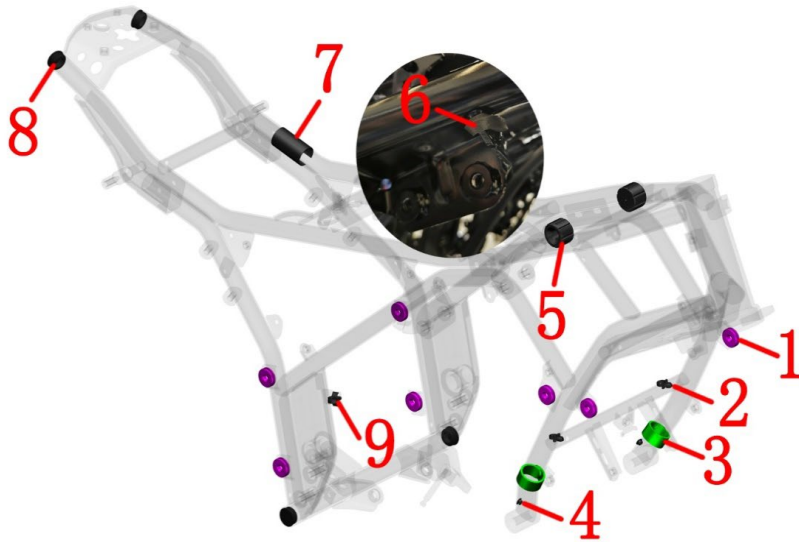

Fig.3 FRAME&ELECTRONIC COMPONENT		Frame plastic parts	CHK	
NO.	PART NO.		PART NAME	
1	1244100-002000	ZT250-S Side cover round rubber	7	
2	1274100-017000	ZT250-S cable buckle	2	
3	1244200-138000	ZT310 rubber buckle (80mm)	2	
4	1246500-027000	KD200-C frame $\phi$ 7 decorative buckle	2	
5	1241200-044000	KD150-U fuel tank liner limit glue	2	
6	1246200-051000	P-240 foam improvement (width 6mm, length 1m, thickness 5mm)	0.1	only for 125/155-C
7	1240100-023000	Battery anode protection glue	1	
8	1244100-061000	ZT250 anti-water rubber of frame	4	
9	1224100-030000	Pin tie (Black 4.8×130)	1	

## PROCEDURE:

- Fuel tank liner limit glue  
Push out the fuel tank liner limit glues(5) then take off.
- Battery cushion  
Put off the battery cushion (8) directly by hand.
- Side cover cushion  
Remove the side cover cushion (1) with your hand directly.
- Rubbers  
Remove the anti-water rubber of frame (8), cable buckle (2) and decorative buckle (4) directly by hand.
- Pin tie  
Cut or pinch the snap on the back and push out the pin tie (9).
- Foam Tape  
A 5-8cm piece of foam tape is affixed to the suspension brackets on both sides of the frame to prevent rattling when the tool box cover and sub-tank cover are too close to the frame, required only for 125/155-C models, not for 200-C.

## CAUTION:

- It must be dismantled them first, such as the cushion, fuel tank component, sider cover, tail dressand so on.
- All parts should be correctly assembled.

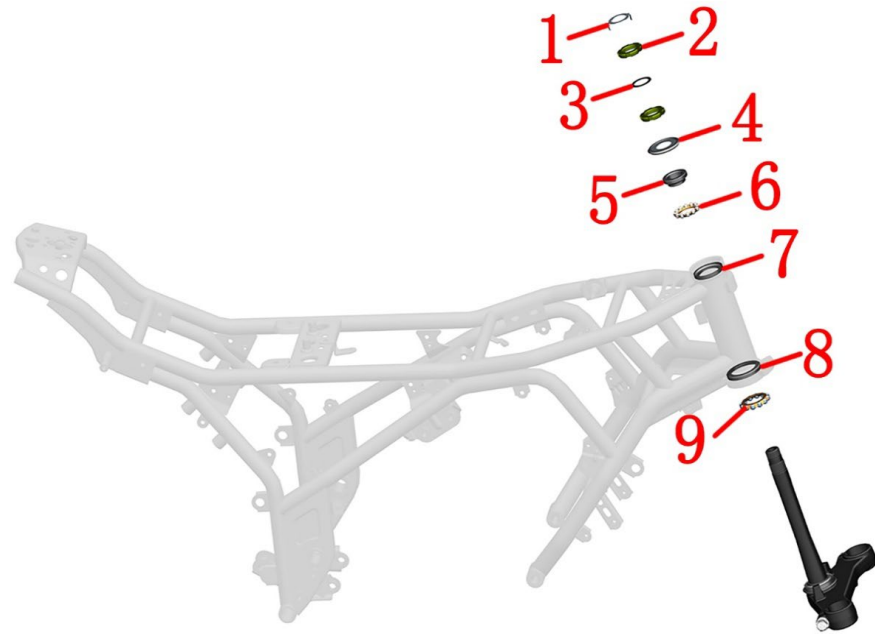
**CAUTION:**

- Remove the head part component, handlebar component and front shock absorber component first.
- Please pay attention to fix the awaiting repair motorcycles during disassembly, prevent dumping by accident.
- Please check whether the steel beads of the conjoined body have abnormal phenomena such as partial abrasion and rust. If YES, please buy the regular accessories, if not, please be sure to grease the old grease and repaint the lubricating grease on it.
- It must be to check whether the steel ball is available during reassembly.
- It must be reasonable to adjust the steering, too loose will cause the locomotive to brake slightly, and the locomotive will shake slightly, too tight can lead to inflexibility, resulting in safety hazards.
- If you have the ability and the right tool, you can change the shaft ring and the dustproof cover. During the replacement process, pay attention to the protection of the lower connected plate. After replacement, it must be to check the parallelism of the column and the damping hole, the vertical degree of the vertical column and the lower connected plate.

Fig.4 FRAME&ELECTRONIC COMPONENT		Directional column component	CHK	
NO.	PART NO.	PART NAME	ADJ	
1	1134100-007000	ZT250-S Adjusting nut locking washer	1	CAUTION
2	1251300-046093	ZT250-S direction column adjusting screw nut M24×1 (environmental color Zinc)	2	
3	1244100-015000	ZT250-S Adjusting nut rubber pad	1	
4	1244300-014000	ZT350-R upper dust cover	1	
5	1130900-024000	ZT250-S shaft ring	1	
6	1130900-022000	ZT250-S conjoined steel ball	1	
7	1130900-026000	ZT250-S upper steel bowl	1	
8	1134300-001000	ZT350-R lower seat ring	1	
9	1134300-002000	ZT350-R conjoined steel ball	1	

**PROCEDURE:**● **Disassembly**

Remove the lock washer(1).

Remove the top adjusting nut (2) by using a special four-jaw or hook wrench tools.

Remove the rubber pad (3).

With one hand to hold down the down connected plate assembly, the other hand use a special four-jaw set or hook wrench to remove the adjusting nut(2).

Remove the down connected plate component.

Remove the upper dustproof cover(4).

Remove the axle ring (5) of the upper riser and the steel ball(6).

Remove the steel ball of the down connected plate component(9).

● **Assemble**

When reassembling, the conjoined steel beads should be painted lubricating grease, attention to the dosage.

The torque of rating nut which closes to upper dustproof cover is required to about 14N·m, so as to be able to rotate out of nimbleness.

The top adjusting nut only needs to rotate to the bottom of the nut groove alignment, not too tight to prevent the rubber pad (3) from deformation too larg.

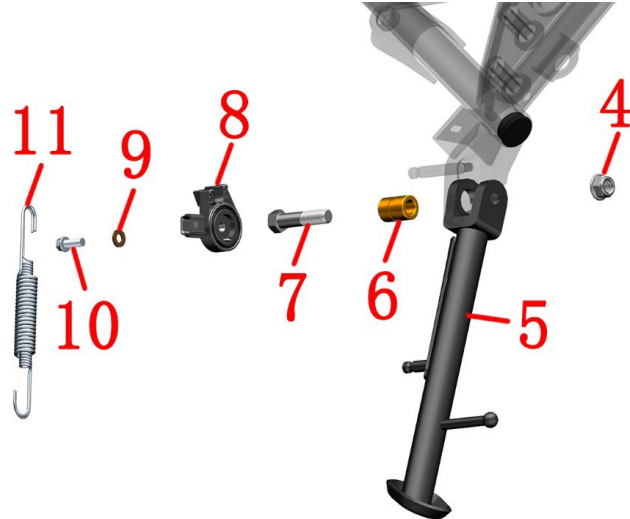
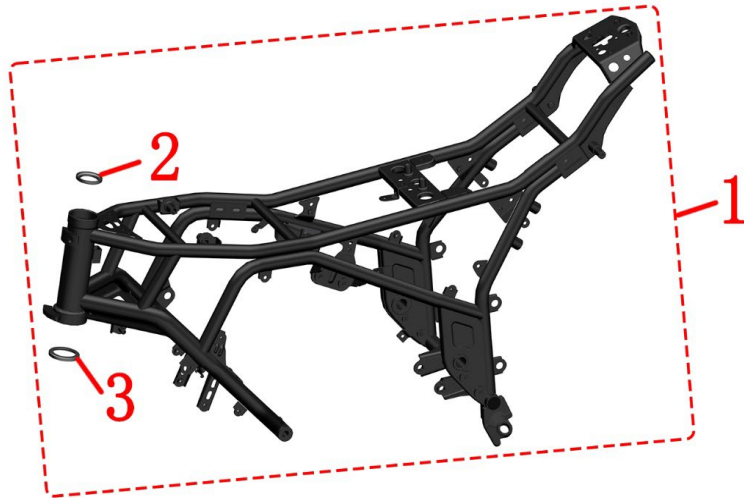

Fig.5 FRAME&ELECTRONIC COMPONENT		Frame, side bracket	CHK	
NO.	PART NO.		ADJ	
		PART NAME	QTY	
1		Frame after-sales component	1	<b>【1】</b>
2	1130900-026000	ZT250-S upper steel bowl	1	
3	1134300-001000	ZT350-R lower seat ring	1	
4	1251300-057093	Non-standard nut M10×1.5(dacromet)	1	
5	4026500-001000	KD200-C side bracket	1	
6	1251700-175091	KD200-C side stand sleeve φ10×φ17×24	1	
7	1251100-365000	Non-standard bolt M10×1.5×45(with threaded hole)	1	
8	1186800-006000	ZT350 side bracket flameout switch	1	
9	1251513-001019	6.3×12×1.6 copper gasket	1	
10	1251112-001093	GB16674 M6×16 Hexagon flange bolts (9.8 grade/environmental color Zinc)	1	
11	1264100-001000	ZT250-S side stand spring	1	

## PROCEDURE:

## ● Checking the cushion loop

Checking whether the cushion loop<sup>(2),(3)</sup> is frayed, if as it, please replace it. Fix the cushion loop well and paint the lubricating grease on it with appropriate tool.

## ● Sider support

Unplug the conector of the flameout switch, using the cross screwdriver to remove the side support spring<sup>(11)</sup>, and guard against the personal injury caused by spring contraction. Using 8# sleeve remove the bolt<sup>(10)</sup>, then take off the gasket<sup>(9)</sup>, the flameout switch<sup>(8)</sup>. Using 14# sleeve fixed the bolt<sup>(7)</sup> and then remove nut<sup>(4)</sup>. Remove the bush<sup>(6)</sup>, side support<sup>(5)</sup>, paint the lubricating grease on the bush<sup>(6)</sup> when re-assembling, then put it into the frame<sup>(1)</sup>.

## CAUTION:

- Remove the wind deflector component, handle bar component, steering column component first.
- Paint the lubricating grease on the cushion ring to decrease the rotary resistance of front forklift.
- Pay attention to safety when mounting side support spring.
- All parts should be correctly assembled.
- **【1】** If the part code is empty, it indicates that the part has multiple states or colors. For specific states, please find the corresponding state or color in the official website parts. Only the disassembly and assembly steps are explained here, and the color and status do not affect the disassembly and assembly process. This description will not be added if there is such a situation later in this manual.

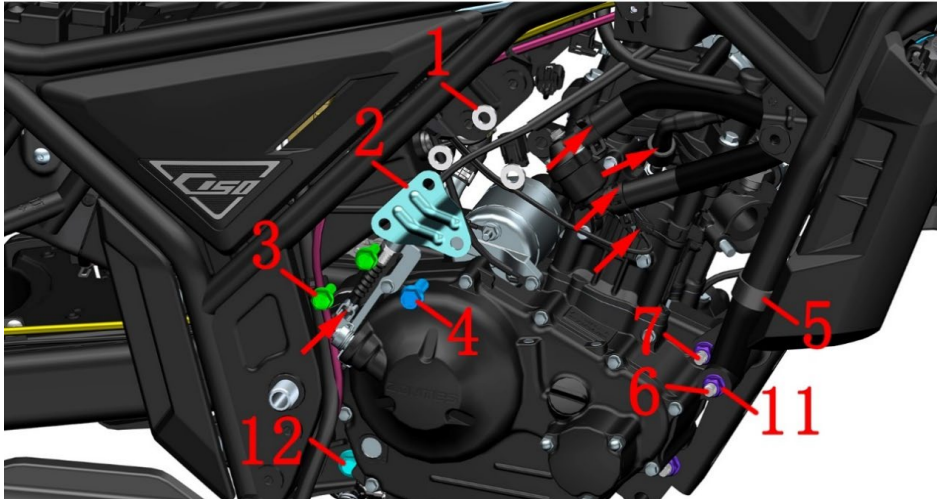
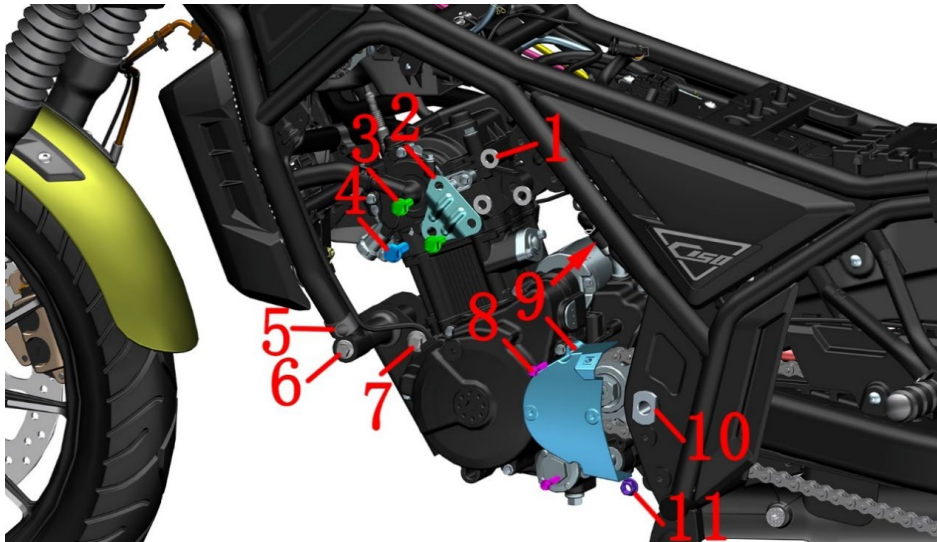

Fig.1 FRAME & ENGINE COMBINATION		Frame & engine combination 1 (125/155CC)	CHK	⚠
			ADJ	
NO.	PART NO.	PART NAME	QTY	CAUTION
1	1251500-116000	Non-standard aluminum washer $\phi 20 \times \phi 10 \times 3$	6	
2	4026500-012000	KD150-C hanging piece	2	
3	1251100-123093	Non-standard bolt M8 $\times$ 25 (color Zinc)	4	
4	1250105-144093	GB5789M10 $\times$ 1.25 $\times$ 30 (environmental color)	2	
5	1244200-138000	ZT310 rubber buckle (80mm)	2	
6	1276500-021000	KD200-C bracket connecting shaft $\phi 10 \times 280$	1	
7	1251100-085093	Non-standard bolt M10 $\times$ 1.5 $\times$ 75 (Dacromet)	2	
8	1251112-002093	GB16674 M6 $\times$ 30 Hexagon flange bolts (9.8 grade/environmental color Zinc)	2	
9	1226500-008000	KD200-C engine left rear cover	1	
10	1252200-084000	KD200-C rear fork axle $\phi 20 \times 320$	1	
11	1251300-057093	Non-standard nut M10 $\times$ 1.5(dacromet)	4	65 $\pm$ 5N.m
12	1251100-261000	Non-standard bolt M10 $\times$ 1.25 $\times$ 127(Dacromet)	1	

## PROCEDURE:

## ● Remove engine accessories

Firstly drain the coolant. Then remove the seat cushion, fuel tank, tool box, sub-tank, surround and bracket, rectifier, pedal bracket, throttle body assembly, and left side cover. Locate and unplug the gear display and magneto, unplug the water temperature sensor on the right side, unplug the ignition coil against the spark plug side, unplug the crankcase exhaust pipe, remove the clutch cable against the engine end, and remove the rear flat fork protective rubber sleeve and nut. Remove the motor positive wire, engine hitch wire, and cooling water pipe.

Remove 2 pieces of rubber buckles(5).

After removing the 2 bolts(3) and bolts(4) securing the hanging piece(2) on the left side with a 12# socket, remove the hanging piece and 3 pieces of aluminum washers(1). Remove the right side hanging piece in the same way.

Remove the left rear cover(9) by removing the bolt(8) with the 8# socket. After removing the rear flat fork shaft, remove the chain from the small sprocket.

Secure the bolts (6), (7) and (12) respectively with a 14# socket, and remove the 4 nuts(11) first with a 14# socket, taking care that the bolts(6), (7) and (12) should not be removed first.

## CAUTION:

● This manual only roughly explains the disassembly steps, and replacing the engine is difficult, so it is recommended to go to a qualified aftermarket store for repairs.

● Using suitable tools to support the motorcycle, in case of accidents caused by motorcycle falling down. Single person operating is prohibited.

● The waste oil and coolant needs to be collected and returned to qualified institutions. It is forbidden to dump and pollute the environment and the source of water.

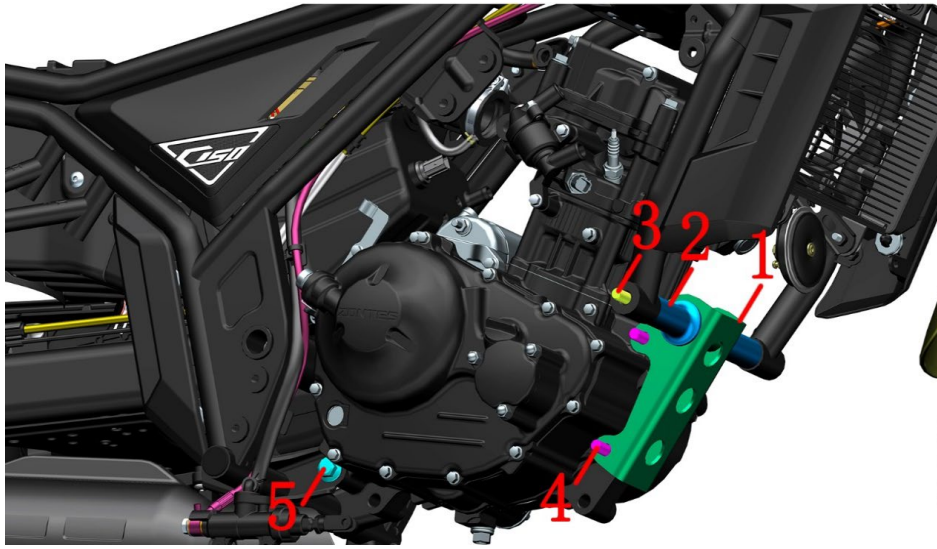

Fig.2 FRAME & ENGINE COMBINATION		Frame & engine combination 2 (125/155CC)	CHK	⚠
			ADJ	
NO.	PART NO.	PART NAME	QTY	CAUTION
1	4026500-002000	KD200-C bracket	1	
2	4026500-009000	KD200-C bracket left-right connecting sleeve	2	
3	1276500-021000	KD200-C bracket connecting shaft $\phi 10 \times 280$	1	
4	1251100-085093	Non-standard bolt M10 $\times$ 1.5 $\times$ 75 (Dacromet)	2	
5	1251100-261000	Non-standard bolt M10 $\times$ 1.25 $\times$ 127(Dacromet)	1	

## PROCEDURE:

- Remove the engine  
Check again that all cables, tubes, etc., connected to the engine have been removed.  
Two persons hold the left and right engine cases at the same time; one person withdraws the shaft (5) and removes the sleeve(2). Remove the bracket(1) after removing the bolt(4).  
Confirm that the engine is supported and then pull out the bolt (5), and then remove the engine from the vehicle, paying attention to safety during the movement. Place the engine smoothly on a flat surface.

## CAUTION:

- Use a suitable tool to support the motorcycle to prevent accidents caused by dumping during disassembly.
- The waste oil and coolant needs to be collected and returned to qualified institutions. It is forbidden to dump and pollute the environment and the source of water.
- Use the appropriate tools to support the whole vehicle to prevent accidents caused by the dumping of the vehicle during the disassembly process; single operation is strictly prohibited.
- All standard parts must meet the standard torque value during reassembly, and re-add the oil according to the instructions."Ⓜ

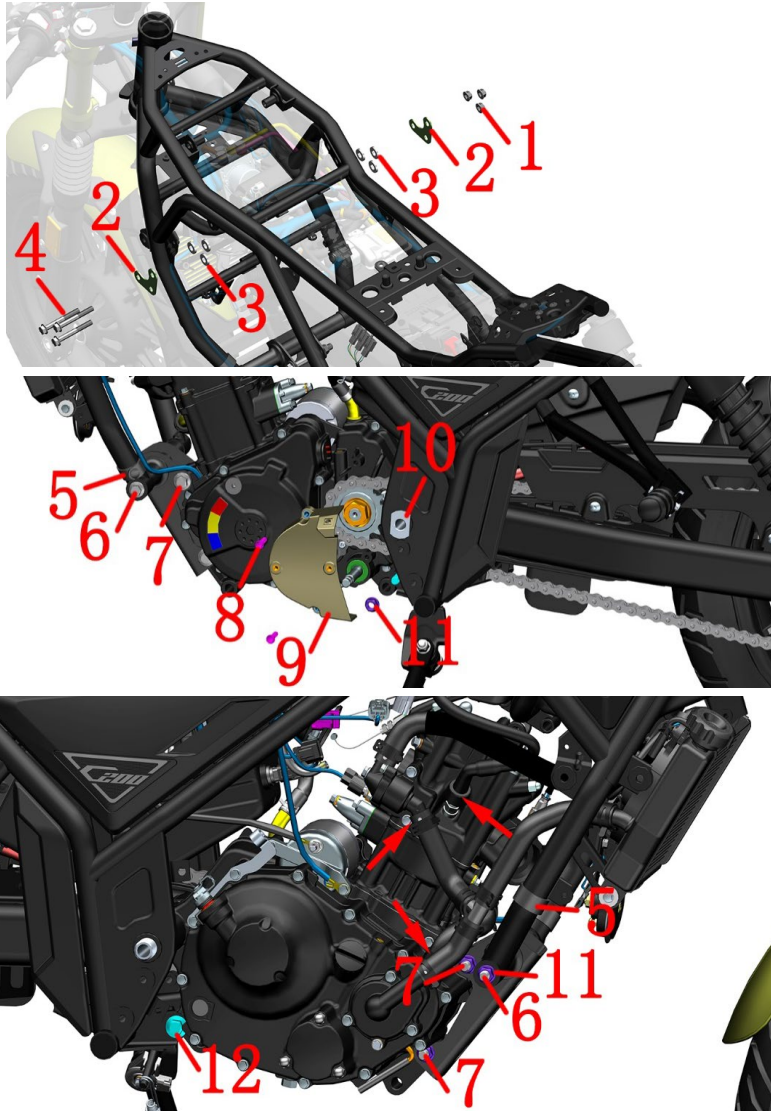

Fig.3 FRAME & ENGINE COMBINATION		Frame & engine combination 1 (200CC)	CHK	CAUTION
			ADJ	
NO.	PART NO.	PART NAME	QTY	
1	1250305-002091	GB6187.1 M8(White Zinc)	3	
2	4026500-007000	KD200-C hanging piece	2	
3	1251500-116000	Non-standard aluminum washer $\phi 20 \times \phi 10 \times 3$	6	New
4	1250105-017091	GB5789M8×65 (10.9 grade/white Zinc)	3	New
	1250105-202091	GB5789M8×60 (10.9 grade/white Zinc)		old
5	1244200-138000	ZT310 rubber buckle (80mm)	2	
6	1276500-021000	KD200-C bracket connecting shaft $\phi 10 \times 280$	1	
7	1251100-085093	Non-standard bolt M10×1.5×75 (Dacromet)	2	
8	1251112-002093	GB16674 M6×30 Hexagon flange bolts	2	
9	1226500-008000	KD200-C engine left rear cover	1	
10	1252200-084000	KD200-C rear fork axle $\phi 20 \times 320$	1	
11	1251300-057093	Non-standard nut M10×1.5(dacromet)	4	65±5N.m
12	1251100-261000	Non-standard bolt M10×1.25×127(Dacromet)	1	

## PROCEDURE:

## ● Remove engine accessories

Firstly drain the coolant. Then remove the seat cushion, fuel tank, tool box, sub-tank, surround and bracket, rectifier, pedal bracket, throttle body assembly, and left side cover. Locate and unplug the gear display and magneto, unplug the water temperature sensor on the right side, unplug the ignition coil against the spark plug side, unplug the crankcase exhaust pipe, remove the clutch cable against the engine end, and remove the rear flat fork protective rubber sleeve and nut. Remove the motor positive wire, engine hitch wire, and cooling water pipe.

Remove 2 pieces of rubber buckles(5).

After fixing 3 bolts(4) on the left side with a 12# socket, remove the nuts(1) on the right side, then take off the hanging piece(2) and 3 pieces of aluminum washers(3). Then take off the bolts(4), the hanging piece(2) and 3 pieces of aluminum washers(3) on the left side.

Remove the left rear cover(9) by removing the bolt(8) with the 8# socket. After removing the rear flat fork shaft, remove the chain from the small sprocket.

Secure the bolts (6), (7) and (12) respectively with a 14# socket, and remove the 4 nuts(1) first with a 14# socket, taking care that the bolts(6), (7) and (12) should not be removed first.

## CAUTION:

- This manual only roughly explains the disassembly steps, and replacing the engine is difficult, so it is recommended to go to a qualified aftermarket store for repairs.
- Using suitable tools to support the motorcycle, in case of accidents caused by motorcycle falling down. Single person operating is prohibited.

● The waste oil and coolant needs to be collected and returned to qualified institutions. It is forbidden to dump and pollute the environment and the source of water.

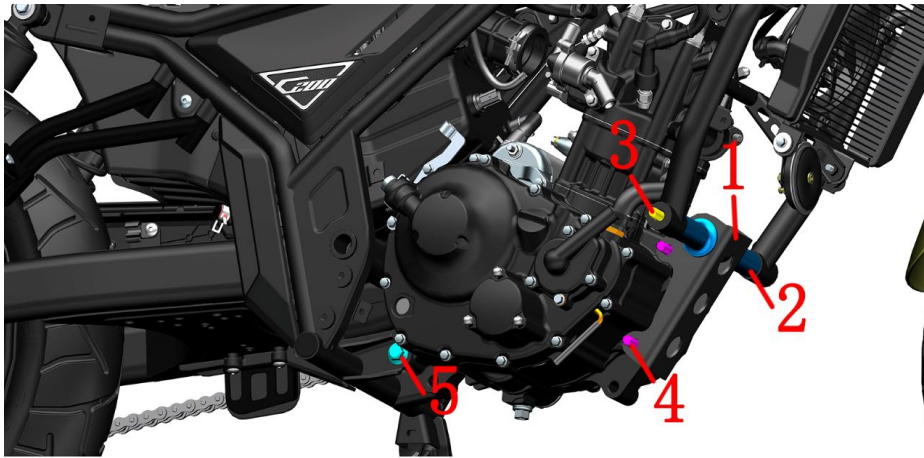



Fig.4 FRAME & ENGINE COMBINATION		Frame & engine combination 2 (200CC)	CHK	
			ADJ	
NO.	PART NO.	PART NAME	QTY	
1	4026500-002000	KD200-C bracket	1	
2	4026500-009000	KD200-C bracket left-right connecting sleeve	2	
3	1276500-021000	KD200-C bracket connecting shaft $\phi 10 \times 280$	1	
4	1251100-085093	Non-standard bolt M10 $\times$ 1.5 $\times$ 75 (Dacromet)	2	
5	1251100-261000	Non-standard bolt M10 $\times$ 1.25 $\times$ 127(Dacromet)	1	

## PROCEDURE:

## ● Remove the engine

Check again that all cables, tubes, etc., connected to the engine have been removed.

Two persons hold the left and right engine cases at the same time; one person withdraws the shaft (5) and removes the sleeve(2). Remove the bracket(1) after removing the bolt(4).

Confirm that the engine is supported and then pull out the bolt (5), and then remove the engine from the vehicle, paying attention to safety during the movement. Place the engine smoothly on a flat surface.

## CAUTION:

- Use a suitable tool to support the motorcycle to prevent accidents caused by dumping during disassembly.
- The waste oil and coolant needs to be collected and returned to qualified institutions. It is forbidden to dump and pollute the environment and the source of water.
- Use the appropriate tools to support the whole vehicle to prevent accidents caused by the dumping of the vehicle during the disassembly process; single operation is strictly prohibited.
- All standard parts must meet the standard torque value during reassembly, and re-add the oil according to the instructions."Ⓜ

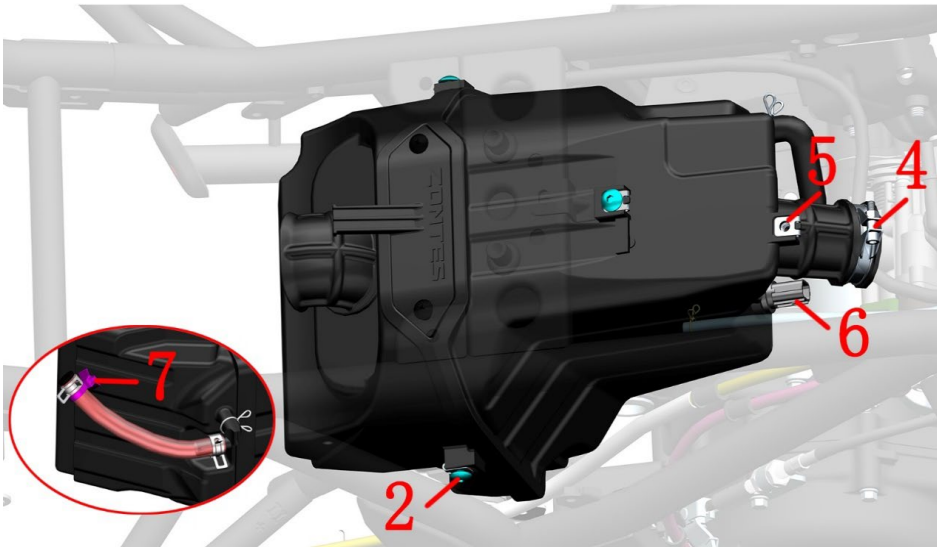
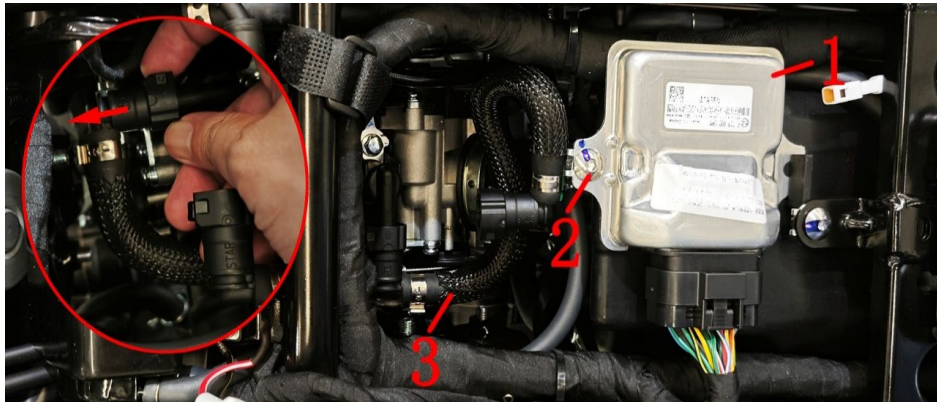
**CAUTION:**

- This manual only roughly explains the disassembly procedure, replacing the air filter requires some hands-on ability, and it is recommended to go to a qualified aftermarket shop for maintenance.
- Regularly check whether the filter element of the carbon tank and air filter is not ventilated, otherwise it may cause the oil supply to affect the driving experience.
- The 2 oil pipes of the canister solenoid valve cannot be connected wrongly.
- Pay attention to force when removing clamp.

Fig.1 INDUCTION SYSTEM COMPONENT		The air filter assembly	CHK	
NO.	PART NO.		ADJ	
1		MSE8.0 Controller (ECU)	1	
2	1251100-101000	Non-standard bolt M6×12 (304 stainless steel)	1	
3	1050957-016000	KD200-C EFI high pressure oil pipe assembly	1	
4	1051356-012000	φ42×10 pipe hoop assembly	1	
5	1251300-063093	Plywood M6×11×15(color Zinc)	4	
6	1050961-004000	Air filter intake air temperature sensor	1	
7	1224100-030000	Pin tie (Black 4.8×130)	1	

**PROCEDURE:****● High pressure oil pipe and ECU**

Remove the high-pressure oil pipe(3) by squeezing the clip on the high-pressure oil pipe with your hand while moving it in the direction of the arrow. Be careful not to damage the injector holder. Remove the plug from the ECU by pressing the plug release catch, and remove the ECU(1) by removing the bolt(2) with a 4# hexagonal socket.

**● Air filter**

Pull out the air filter inlet air temperature sensor.

Remove the fuel tank, seat cushion, side cover, rear box of electrical parts, rear flat fork, etc. The specific steps are detailed in the corresponding chapters and will not be repeated here. Carbon canister solenoid valve removal is detailed in the side cover removal section.

Remove the Air filter intake air temperature sensor(6) on the air filter. If the sealant falls off when you pull out the sensor(6), plug it back to the original position.

First use 4# inner hexagon to remove the 3 bolts (1) on the frame.

Loosen the hose clamp assembly (4) at the end of the air filter and move the clamp out toward the air filter, and pull out the air filter outlet pipe from the throttle valve body.

Use pliers to clamp the hoop on the gas separator outlet pipe, and then plug it with the rubber plug to prevent foreign matter from entering and damaging the engine.

Remove the air filter and carbon canister assembly.

Take off 4 pcs plywood (5) from the air filter.

**● Check sensor**

Check the carbon canister solenoid valve:

In case of poor engine performance; Poor idle speed; If the air-fuel ratio is incorrect, check the carbon canister solenoid valve.

Use a multimeter to measure the resistance between the two inserts of the carbon canister solenoid valve

Check whether the temperature sensor is damaged:

Remove the temperature sensor from the air filter and place it in the ambient temperature (20 ~ 30 °C), and use a multimeter to check whether the resistance of the two pins is between 2726 ~ 1770 Ω.



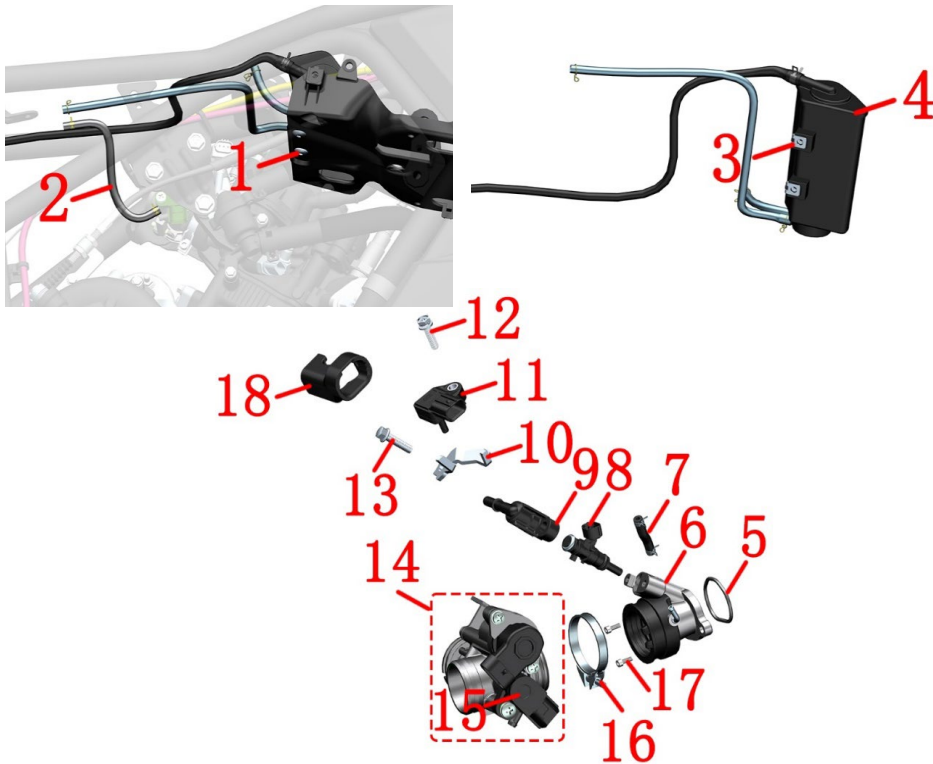

Fig.2 INDUCTION SYSTEM COMPONENT		Throttle valve body component(125CC)	CHK	CAUTION
NO.	PART NO.	PART NAME	ADJ	
1	1251100-101000	Non-standard bolt M6×12 (304 stainless steel)	2	
2	1050957-018000	KD200-C carbon canister EVAP tekmar-dohrmann	1	
3	1251300-063093	Plywood M6×11×15(color Zinc)	2	
4	1226500-003000	KD200-C carbon canister	1	
5	1051468-007000	31.8×2 fluorine rubber O-ring	1	125CC
6	1050955-008000	ZT152MI intake pipe assembly (with intake pressure sensor)	1	125CC
7	1050956-022000	intake pressure sensor connecting hose (φ3.5×φ7.5×L38.5)	1	
8	1050968-003000	EV14 injector G06	1	
9	1050968-002000	ZT1P58MJ injector holder	1	
10	1050956-025000	KD150 external intake pressure sensor fixing bracket	1	
11	1050961-003000	External intake pressure sensor MAP01(18590H7U300)	1	
12	1250106-112000	GB9074.13 combination bolt M5×20	1	
13	1251100-061093	M6×22 Hex flange bolt thread level 8.8 (color zinc)	1	
14	1050955-002000	ZT26 Throttle Body Assembly (position sensor)	1	125CC
15	1050954-043000	Left hole angle sensor bushing (RPAZ023A—5K)	1	125CC,after-sale
16		pipe clamp assembly	1	
17	1250205-036097	Gb70.1m6 ×16 (Chrome plated)	2	
18	1050957-021000	Pressure sensor fixing rubber sleeve	1	

## PROCEDURE:

## ●Carbon canister assembly

After removing the left sub-tank and right tool box, remove the carbon canister assembly from the vehicle by removing the bottom bolt(1) with a 4# hex. Remove 2 pcs plywood(3). Remove the tekmar-dohrmann(2).

## ●Throttle valve body assembly

Unplug the connector of the throttle valve body assembly, and remove the pipe clamp (16) with a 4# hexagonal socket to remove the throttle valve body assembly. Remove the throttle cable and then take off the throttle body(14). Unplug the sensor(11)and injector(8) and remove the intake manifold assembly by removing 2 bolts(17) with a 4# hexagon socket.

Remove the O-ring (5), check carefully for damage before reinstalling.

Remove the connection hose(7) at the intake pipe assembly end.

Use 8# wrench to remove the bolt (13),take off the External intake air pressure sensor component,injector holde(9)and injector(8).

## ●External intake air pressure sensor

Using screwdriver for cruciform head remove the bolt (12),take off the sensor(11)and support(10),then remove the connection hose(7).Remove the rubber sleeve(18),added from approximately Oct.24,2023.

## CAUTION:

●This is an example of how to disassemble the throttle valve body assembly for the 125 displacement model. The steps for the 155 and 200 displacement models are similar, with only some of the parts differing

in appearance, so they will not be repeated.

## ●Check whether the external intake pressure sensor is damaged

Loosen the connector and check whether the pin is skewed or broken. The vehicle is connected to the diagnostic instrument without ignition. Check the engine parameters to see whether the pressure parameters are consistent with the local atmospheric pressure.

## ●Check whether the fuel injector is damaged

Remove the manifold without loosening the plug of electrical parts. Press the ignition button to check whether the two beams of oil mist emitted by the fuel injector are uniform.

## ●Check whether the stepping motor is damaged

After turning off the power, take out the stepping motor, do not loosen the cable plug, press the flameout switch at startup without ignition, check whether the motor plug can shrink back and forth, and finally turn off the flameout switch to check whether the plug returns to its original position.

## ●Check whether the throttle position sensor (15) is damaged

Connect the diagnostic instrument to the whole vehicle, press the flameout switch (without ignition), turn the throttle handle from the initial position to fully open, and check whether the throttle position signal changes from 0 to 100.

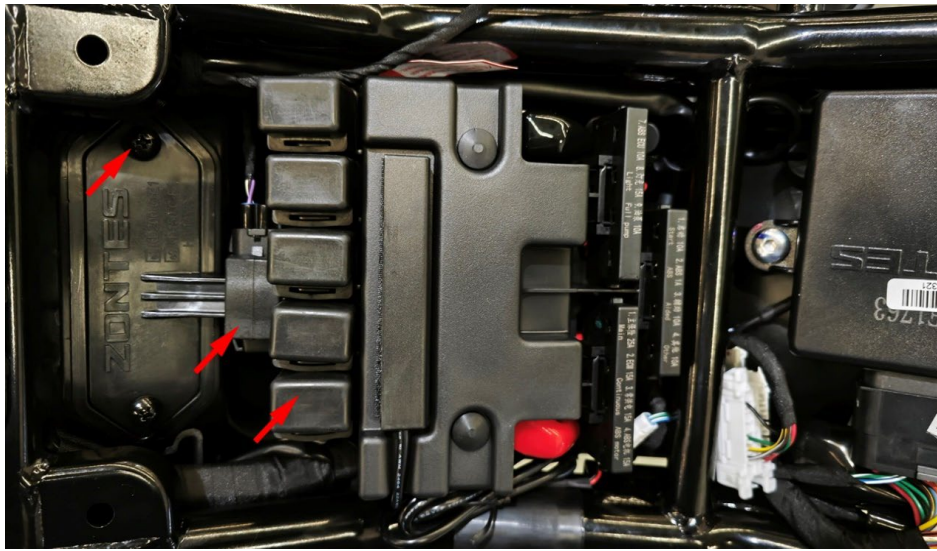

Fig.3 INDUCTION SYSTEM COMPONENT		Replace air filter element	CHK	
			ADJ	
NO.	PART NO.	PART NAME	QTY	CAUTION
1	1226400-174000	ZT310-R Air Filter Element (carton packaging)	1	

**PROCEDURE:**

● **Filter element**

If you need to maintain the filter element of the air filter, remove the seat cushion. Lift the battery cover and relay assembly up and out of the way, and pull the dump switch rubber sleeve out of the filter cartridge cover. Take the two standard screws out of air filter, dismantle the box cover. Grasp the rubber strips on the filter (both sides shown in yellow) and pull the filter element out. Blow the dust off the filter core by blowing dust gun in the filter element. If the filter paper is damaged, it should be replaced in time. If the blowback causes the dust to be unable to clean up, the engine will be damaged or the induction resistance will become larger and affect the driving experience. When assembling, apply a small amount of engine oil on the upper and lower sides of the rubber strip (shown in cyan as shown in the figure) to reduce assembly resistance.

● **Oil pipe and water pipe**

Avoid water into the air filter when washing the motorcycle. Can pulled out the oil pipe to release if into small water. keep no water inside before starting the engine. Inspect the oil pipe regularly if more oil is accumulated should be released in time.

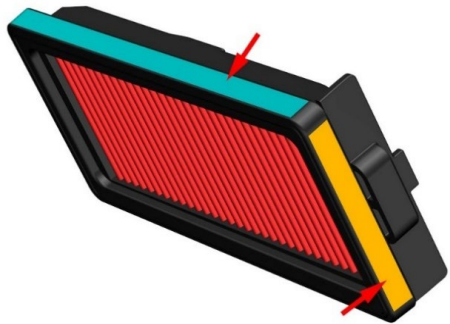

**CAUTION:**

- Regularly check whether the filter element of the carbon tank and air filter is not ventilated, otherwise it may cause the oil supply to affect the driving experience.
- When blowing dust, pay attention to maintain a certain distance to avoid excessive damage to the filter element.
- The filter element should be checked every 5000 kilometers or 15 months; it should be replaced every 10,000 kilometers or 30 months.

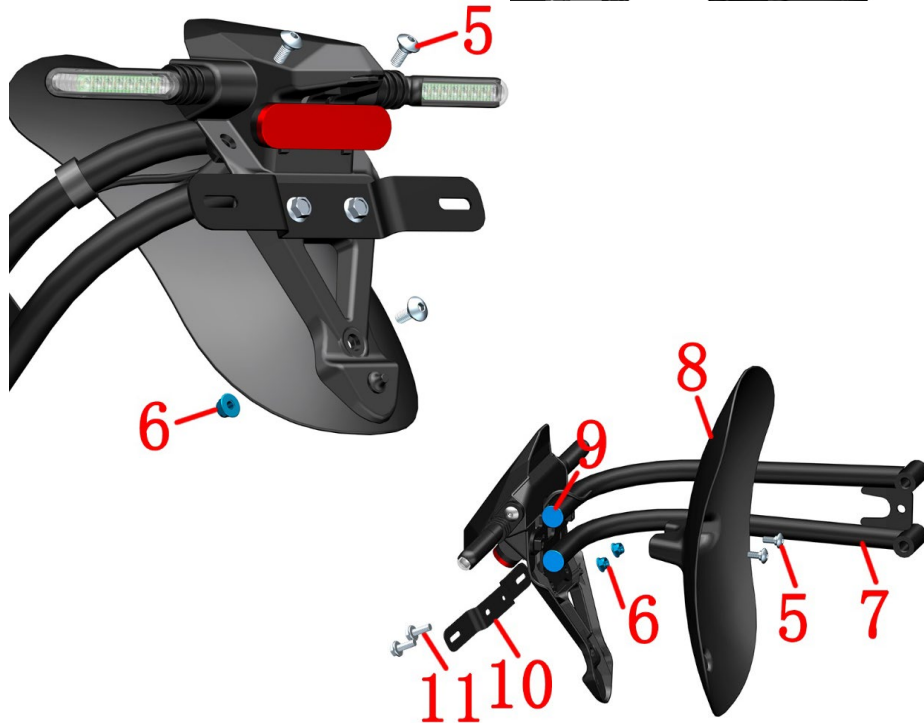
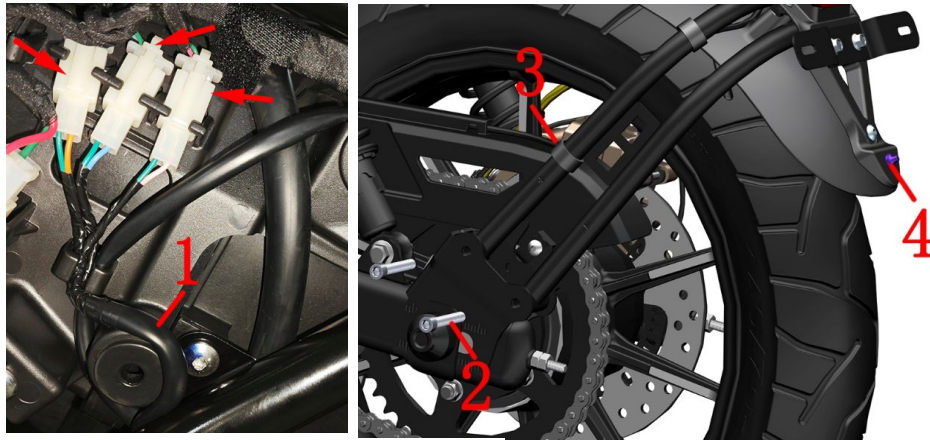

Fig.1 REAR WHEEL COMPONENT		Rear mud board-1	CHK	⚠
			ADJ	
NO.	PART NO.	PART NAME	QTY	CAUTION
1	1186500-006000	KD200-C auxiliary mud plate transfer line	1	
2	1250205-036091	GB70.1M8×50(white Zinc)	2	
3	1244300-023000	ZT310 rubber buckle (50mm)	2	
4	1244100-006000	ZT250-S rear liceness rubber buffer	1	
5	1251100-328000	Hexagon socket head screw M6×14+8.5×3 SUS302	5	
6	1250305-010093	GB6187.1M6 (environmental color)	3	
7	4026500-003000	KD200-C rear auxiliary fender bracket	1	
8	1226500-011000	KD200-C rear auxiliary fender	1	
9	1244200-052000	ZT310 univseral side box bracket waterproof rubber plug	2	
10	1270300-039000	HJ125-6 rear license plate bracket	1	stop selling
	1276500-011021	KD200-C rear license plate bracket		
11	1250105-138093	GB5789M6×20 (environmental color)	2	

## PROCEDURE:

## ●Rear auxiliary mudguard component

Remove the left side cover assembly first and unplug the 3 plugs indicated by the arrows. Pull the adapter wire out of the wire slot above the chain box.

Remove the rubber buckle(3) and the rear liceness rubber buffer(4).

Remove the 2 pieces of bolts(2) with a 6# hex and the rear sub mud board assembly.

Secure the bottom screw(5)with a 4# hex and remove the nut(6) with a 10# socket.

Remove the top 2 screws(5)with a 4# hex.

Turn over to the back and remove the rear auxiliary fender(8) by removing the two screws(5) with a 4# hex.

After securing the bolts(11)with a 10# socket remove the two nuts(6) securing the rear license plate bracket (10) with a 10# socket and remove the licence plate bracket. Remove the 2 pieces of waterproof rubber plugs (9).

Unplug the turn signal licence plate light from the adapter cable and remove the adapter cable.

## CAUTION:

●Using side support to support the motorcycle, in case of accidents caused by motorcycle falling down.

Single person operating is prohibited.

●Stay alert during the manipulation and avoid accident.

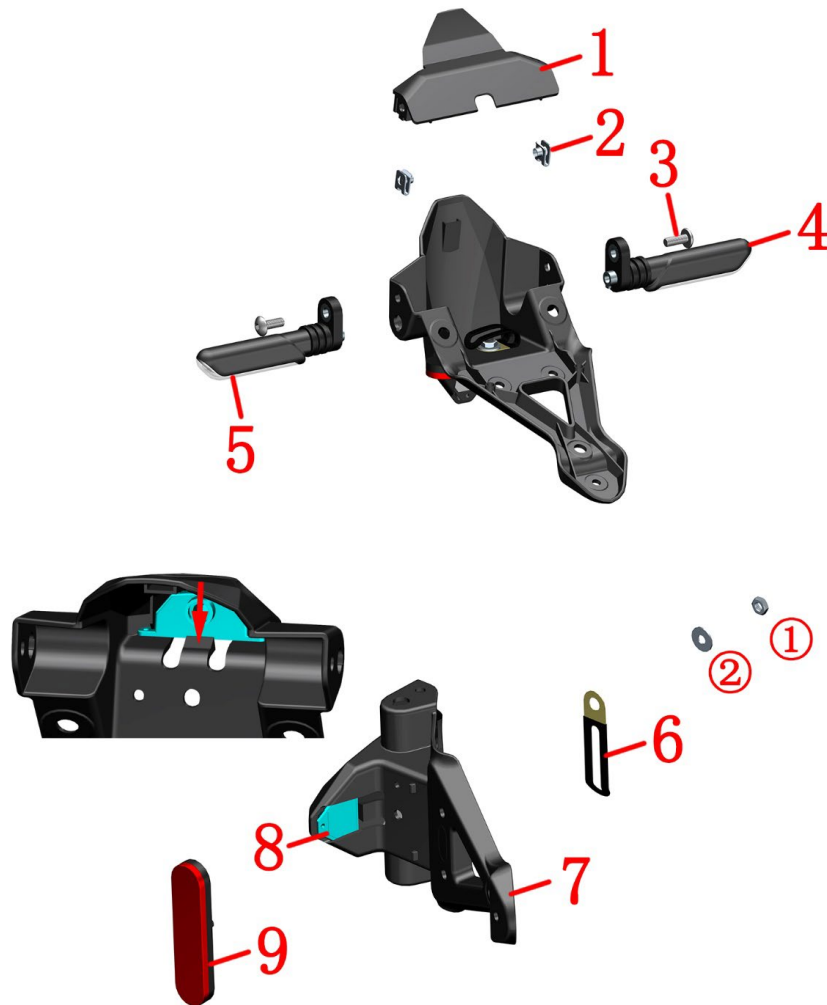

Fig.2REAR WHELL COMPONENT		Rear mud board-2	CHK	
			ADJ	
NO.	PART NO.	PART NAME	QTY	CAUTION
1	1226500-009000	KD200-C licence plate mounting plate backing	1	
2	1251300-063093	Plywood M6×11×15(color Zinc)	2	
3	1251100-102000	Non-standard bolt M6×16 (304 stainless steel)	2	
4	1176500-006000	KD200-C left turn signal (L=100mm)	1	
5	1176500-007000	KD200-C right turn signal (L=100mm)	1	
6	1270300-273000	φ8 clip(L=73)	1	
7	1226500-010000	KD200-C plate mounting plate	1	
8	1174200-021000	ZT310-X Liensed lights	1	
9	1174100-002000	ZT250-S rear reflector	1	

## PROCEDURE:

## ●Rear licence plate mounting plate

Remove the bottom liner assembly by removing each of the 2 pieces of bolts(3)with a 4# hex. Remove the plywood(2) from the backing(1). Remove the turn signal light from the plate mounting plate(7). Remove the adapter wire by breaking the wire clip straight and unplugging the turn signal and licence plate light.

Remove the nut ①and spacer② supplied with the rear reflector(9) with a 10# socket, and remove the wire clip(6). Remove the licence light(8) by pressing the snap at the arrow indication.

## CAUTION:

●When reinstalling, pay attention to differentiate the turn signal wire colours to avoid inserting them backwards.

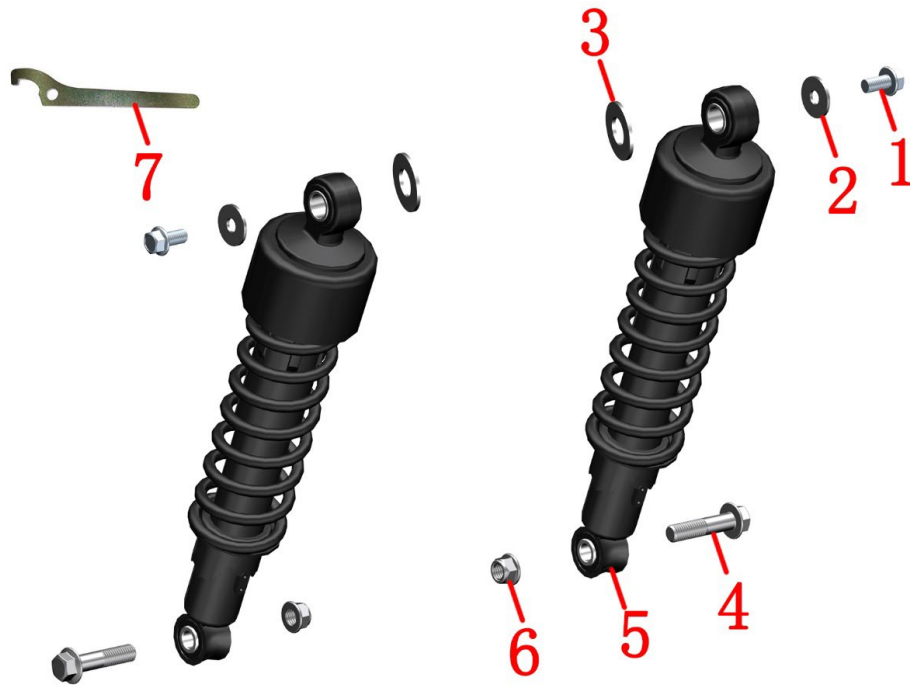



Fig.3 REAR WHEEL COMPONENT		Rear shock absorption	CHK	
			ADJ	
NO.	PART NO.	PART NAME	QTY	CAUTION
1	1250105-147093	GB5789M8×16 (environmental color)	2	
2	1250502-016093	GB96.1φ8 (environmental color)	2	
3	1276600-015097	Φ30×Φ14.5×2 gasket (chromed)	2	
4	1251100-088094	Non-standard bolt M10×1.5×43(Dacromet)	2	
5	1116500-003000	KD200-C rear shock absorber	2	
6	1251300-057093	Non-standard nut M10×1.5(dacromet)	2	
7	1276400-077000	ZT350T-K rear shock absorber adjustment wrench	1	gift of vehicle

## PROCEDURE:

## ●Rear shock absorber

Put down side stand. Person 1: Turn the handling bar to left end with left hand; hold tight the rear pedal with right hand and lean the motorcycle to left side. Another person used a wooden stool to put a soft rubber cushion on the right side muffler back pressure bag of the bike to support the whole bike and let the rear wheel slightly off the ground.

After supporting the whole bike, use a 14# wrench to fix the nut (6) at the bottom of the shock absorber. Uses a 14# sleeve on the out side to loosen the bolt (4) counterclockwise and remove the nut (6).

Remove the bolt(1) with a 12# sleeve, take off the gasket(2), and then take off the rear absorber at, last take off the gasket(3).

## ●Adjust the rear absorber

Use the supplied hook spanner to turn the adjusting nut clockwise to compress the damping spring and thus stiffen the damping, and conversely to soften it. Please adjust in a reasonable range. Riding experience would be influenced either the absorber is too soft or too hard.

## CAUTION:

●Using suitable tool to support the motorcycle. Avoid accidents caused by falling motorcycle. Single person manipulation is prohibited.

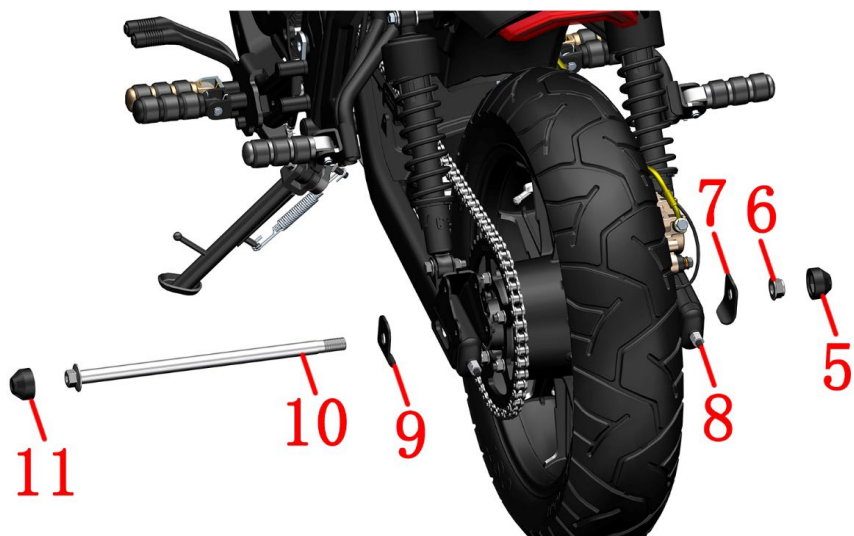
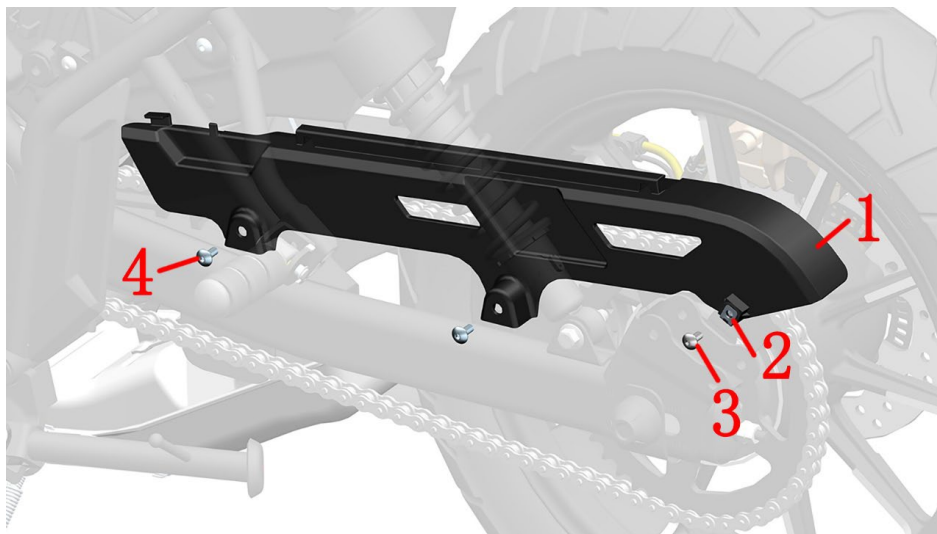

Fig.3 REAR WHELL COMPONENT		Rear wheel component 1	CHK	⚠
NO.	PART NO.	PART NAME	ADJ	
1	4046502-039000	KD200-C chain cover assembly (MES)	1	
2	1251300-063093	Plywood M6×11×15(color Zinc)	1	
3	1251100-101000	Non-standard bolt M6×12 (304 stainless steel)	1	
4	1251100-328000	Hexagon socket head screw M6×14+8.5×3 SUS302	2	
5	1246500-016000	KD200-C rear wheel shaft protection rubber sleeve	1	
6	1250305-029000	GB6187.1M16×1.5 (Dacromet)	1	80N.m
7	1276500-007000	KD200-C right chain adjuster scaleplate	1	
8		Chain adjuster	2	
9	1276500-006000	KD200-C left chain adjuster scaleplate	1	
10	1096500-004000	KD200-C rear wheel axle (φ17×344)	1	
11	1246500-021021	KD200-C rear wheel shaft head protection rubber sleeve	1	

## PROCEDURE:

## ●Chain box

To prevent damage to the chain box when removing the rear wheel assembly, remove it first. Remove the chain box assembly from the vehicle by removing the 1 bolt (3) and 2 screws(4) with a 4# hex. Remove the plywood(2).

## ●Rear wheel assembly

Remove the protection rubber sleeve(6) and(11). Loosen the nuts of the chain adjusters on both sides first with a 13# spanner. Secure the head of the rear wheel axle(10) with a 19# socket on the left side and remove the nut (6) with a 21# socket on the right side. Remove the right chain adjuster scaleplate(7).

Tie the rear disc brake caliper to the rear flat fork with a tie or rope. Push the rear wheel assembly toward the front of the motorcycle to the end and remove the chain from the chain disc. Tap the rear wheel axle(10) with a rubber mallet after holding the rear wheel assembly, and remove the right side chain adjuster(8), the rear tyre and rim assembly, and the left side chain adjuster(8)in turn.

## CAUTION:

- Use suitable tool to support the motorcycle. Avoid accidents caused by falling motorcycle. Single person manipulation is prohibited.All the standard parts need to reach standard torque while reassembling.
- Using iron hammer to punch rear wheel axle, disc brake clamp assembly is prohibitd.
- While disassembling the rear wheel assemble, avoid the rear disc brake clamp to be lifted higher than the disc brake oil cup. If not, air will get into the tubes and cause softness or failure on braking system. As disc brake tubes request extremely high vaccum degree. Make sure manipulator has maintenance ability before disassembling the disc brake assembly.
- Check the chain regularly. Increase the frequency of adjustment of the chain according to the driving conditions. Keep the tightness of chain to be in a suitable range. Too loose chain have possibility to separate from sprocket or damage the engine. Too tight chain can be worn out quickly.

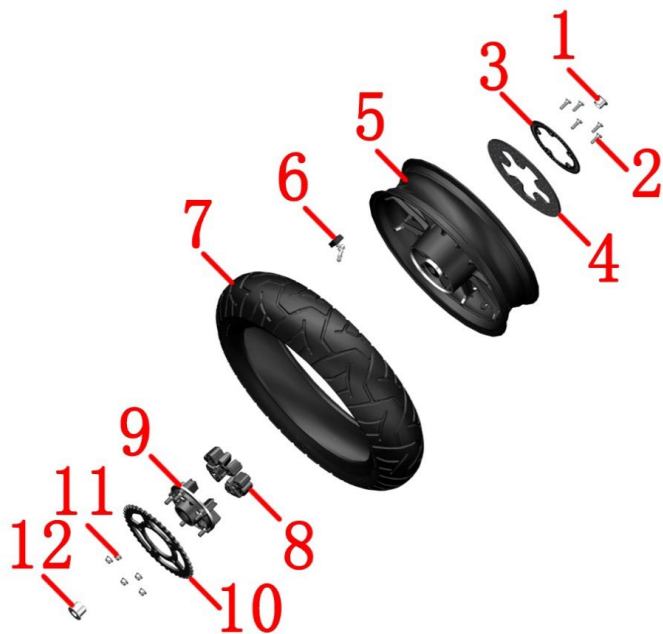

Fig.4 REAR WHELL COMPONENT		Rear wheel component 2	CHK	
			ADJ	
NO.	PART NO.	PART NAME	QTY	CAUTION
1	1276500-004000	KD200-C rear right wheel bushing (φ17×φ22×24/shoulder outer diameter φ30×3)	1	
2	1251100-117093	Non-standard inner hex bolt M8×25 (environmental color)	5	22~24N·m
3	1100100-988000	KD200-C rear wheel induction ring gear (50 teeth)	1	
4	1100100-600000	KD150-U rear brake disc (230 × 4.5/KD)	1	
5	1096500-002000	KD200-C rear aluminum wheel (MT3.75×16/black)	1	
6	1184300-056000	ZT350 Tire Pressure Sensor N (M8 Elbow/120°)	1	
7	1230100-715000	140/70 - 16 CM668 65P TL E4	1	
8	1246500-025000	KD200-C sprocket buffer rubber	5	
9	1094200-069000	KD200-C sprocket seat	1	
10		Sprocket	1	
11	1251300-057093	Non-standard nut M10×1.5(dacromet)	5	
12	1276500-003000	KD200-C rear left wheel bushing (φ17×φ30×26/shoulder outer diameter φ38×3)	1	

## PROCEDURE:

## ●Disc brake plate, ABS gear ring

Remove the right bushing(1) and the left bushing (12).

Using 6# inner hexagon socket remove bolts(2),remove ABS gear ring(3) and disc brake plate(4).

## ●Sprocket bracket assembly

Put down the rear wheel assemble horizontally. Take off nut(11) with 14# sleeve. Take off sprocket(10); sprocket bracket(9). Pull out the sprocket gum cushion(8) from the rim.

## ●Tire and wheel component

Remove the Tire pressure sensor (6) built-in valve cap use a tool to release the air, then use a professional tire puller to remove the rear tire (7). Be careful to avoid the tire pressure sensor. Use 2.5# hexagonal socket to remove the bolt that comes with the tyre pressure sensor and then remove the sensor body, use 12# socket to remove the nut and pad that comes with it and then remove the valve mouth. Be careful not to lose the O-ring that comes with the valve mouth when installing, and check if the O-ring is aging or broken before installing.

## CAUTION:

●Be careful while disassembling the tire and rim in case of damages on the components.

●After changing the tire, check air proof performance.

●Not enough tire pressure can cause abnormal wear and tare. Too high pressure in summer might have

●It needs running-in for about 300km after changing new arresters. During this period, leave enough braking distance while riging.

●The tire repair fluid should not be used because it will block the stoma of the pressure monitoring sensor,resulting in difficulty in inflating or failure of tire pressure momnitoring .

## ●Maintenance

Tire: Check regularly the tire on cracks and air pressure.If the tire is ware to the marker, change the tire with same specification. See details in user manual. Ingradient of tire include semi hot melt rubber. Area with too high temperature is not suitable. If temperature of outdoor is too low, storing the motorcycle in warm place or indoor is suggested in order to avoid frost crack. Normal temperaturestandard 215kPa.

Rim: Check if the rim has deformation or crack. Support the rim horizontally and check if it can rotate smoothly. Specification of oil seal on rear rim is TCφ22×φ47×7. Bearing type: φ17×φ47×14,6303RS.

Disc brake plate: Thickness can not be less than 4mm. If not, change it.



Fig.5 REAR WHEEL COMPONENT		Rear fork component	CHK	⚠
			ADJ	
NO.	PART NO.	PART NAME	QTY	CAUTION
1	1246500-017000	KD200-C Rear Flat Fork Axle Protection Rubber Sleeve	1	
2	1251300-067000	ZT250-R rear wheel hollow shaft nut	1	
3	1252200-084000	KD200-C rear fork axle $\phi 20 \times 320$	1	
4		Chain	1	
5	1246500-006000	KD200-C rear swingarm wear block	1	
6	1276500-009000	KD200-C Rear Flat Fork Anti-friction Block Fixing Bracket	1	
7	1251100-102000	Non-standard bolt M6×16 (304 stainless steel)	2	
8	4076500-004000	KD200-C Rear Flat Fork Press Fit Assembly (MES)	1	
9	1244200-079000	ZT310 single rocker arm $\Phi 25 \times \Phi 32 \times 4$ oil seal	4	
10	1250602-035000	HK2516 needle roller bearing	4	
11	1276500-008000	KD200-C rear fork axle bushing	2	
12	1251100-101000	Non-standard bolt M6×12 (304 stainless steel)	2	
13	1224200-003000	ZT310-R Rear disc brake pipe clamp	2	

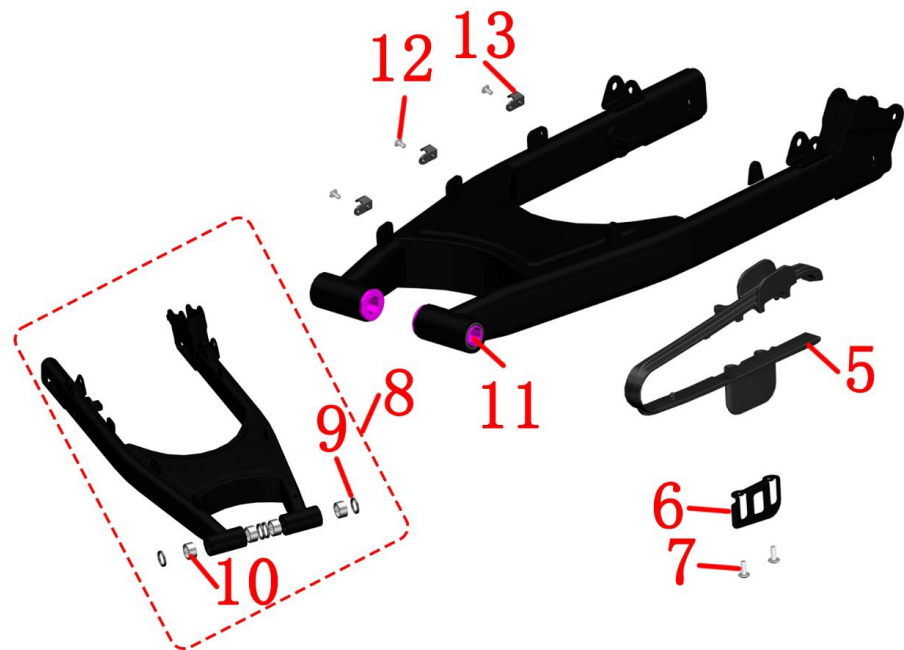

## PROCEDURE:

## ●Rear fork assembly

Remove the rubber cover(1),and take off the wheel sensor wire and the RC oil pipe from the pipe clamp(13).

Person 1 fastensthe head of the rear fork shaft(3), person 2 remove the nut(2) with a 30# sleeve.

Person 1 holds the rear fork assembly and the other person removes the rear fork shaft (3) with suitable tool and then remove the rear fork assembly.

## ●Rear fork rear-resistant block

Using 4# inner hexagon socket remove 2pcs bolts(7),take off the bracket(6),and then remove the wear-resistant block(5).

Put the rear fork bushing (11) inward and remove it.

Oil seal(9) and needle bearing(10) are used for interference compression.

Please ensure that you have the ability to disassemble and disassemble.

## CAUTION:

●Be sure to fix up the motorcycle in the process of disassembly.

●Do not use a hammer to hit the rear fork shaft thread.

●The rear disc brake caliper must not be higher than the disc brake oil cup, otherwise the brake will become soft or fail due to air entering the pipeline. Because the brake line requires extremely high vacuum, it is necessary to ensure sufficient capacity for repair and disassembly.



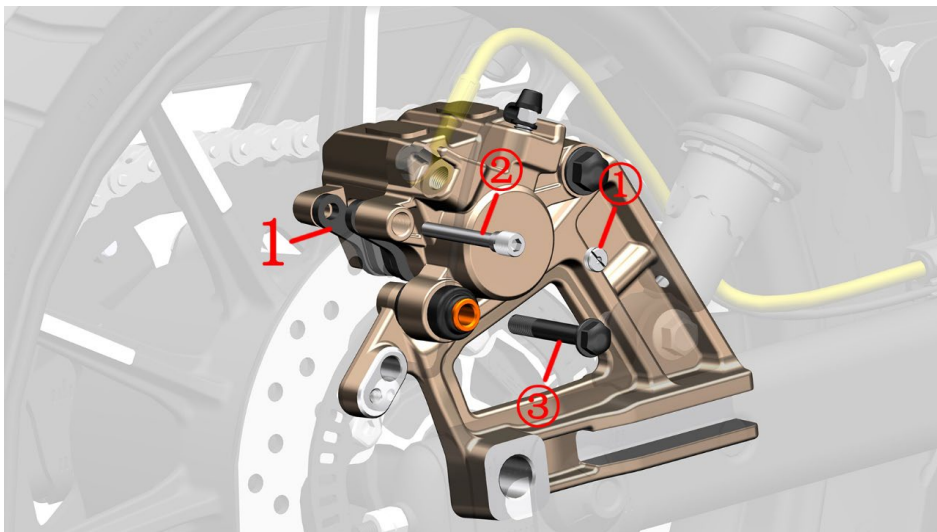

Fig.6 REAR WHEEL COMPONENT		Replace the rear brake pads	CHK	
			ADJ	
NO.	PART NO.	PART NAME	QTY	CAUTION
1	1100100-092000	ZT250—S rear disk brake piece (HS10)	1	After-sales

## PROCEDURE:

## ● Disassemble disc brake arrester

Using strait screwdriver to disassemble nut①.

Disassemble pin axle② with a 5# inner hexagon socket.

Disassemble rolling axle③ with socket sleeve.

Take off rear disc brake arrester(1).

## ● Change rear disc brake arrester

Put the piston of clamp towards the direction of arrow to the end. See photo left below. To reduce resistance, you can disassemble the cross bolt on rear disc brake main pump oil cup. Take off the top cover and sealing gasket. Remember to rebound the pister afterwards.

The new arrester must fit tightly the slot. See photo right below.

Tighten the pin axle② with 5# inner hexagon socket tool.

Tighten rolling axle③ with socket sleeve.

Tighten nut① with strait screwdriver.

Step on braking pedal several times until braking force is recovered.

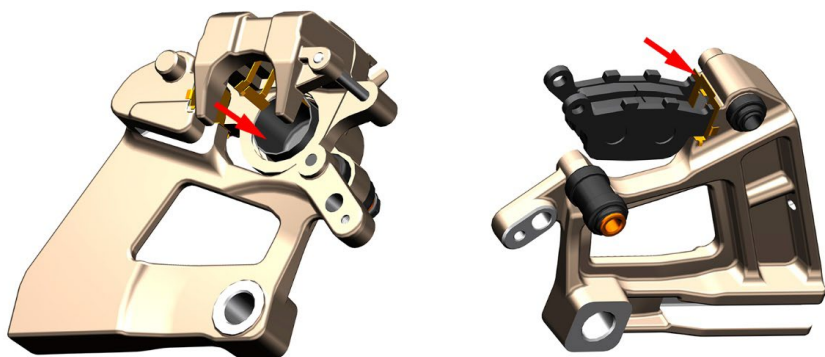

## CAUTION:

● Check regularly the arrester and disc brake plate status.

● To change arresters in qualified mainenance spot are suggested.

● After changing the arrester, adjust the height of braking pedal according to "Foot pedal, gear shift rod assembly" if necessary.

● It needs running-in for about 300km after changing new arresters. During this period, leave enough braking distance while riging.

Fig.7 REAR WHELL COMPONENT	Rear brake main pump adds brake fluid	CHK	
		ADJ	

**PROCEDURE:**

- Add disc brake liquid
- Remove the right side cover assembly.
- Cover the parts near the oil cup with a waterproof plastic bag to prevent the brake fluid from dripping onto the parts surface and causing corrosion.
- Disassemble bolt① with "L" cross screwdriver.
- Take off oil cup cap②, sealing gasket③.
- Add DOT4 braking liquid. Ensure the liquid level is between "UPPER" and "LOWER".
- While reassemble, pay attention install sealing gasket③ in correct position and direction.
- Step gently on the pedal constantly. Do not ride the motorcycle until the braking force is recovered.

**CAUTION:**

- Support the motorcycle well on flat ground before checking.
- Check regularly if the braking liquid surface is between "UPPER" and "LOWER".
- If liquid surface is below "LOWER", check the arrester status and confirm if the braking system is leaking.
- If the braking liquid is accidentally swallowed, contact intoxication center or hospital immediately. If it gets into the eye, wash it away with clean water then see the doctor.
- Keep the braking liquid far away from children and pets.
- Flush the oil cup directly with high pressure water is prohibited.
- Mixing water, dust, impurity and liquid of silicic acid or petrol series into the braking liquid is prohibited. Otherwise, the braking system would be damaged.
- It must be used in time after opening, and it is necessary to seal and prevent moisture during storage; it is recommended not to exceed one month. Inferior or damp brake oil can cause poor braking system and can cause brake failure if the impact is severe. Be sure to replace the brake fluid in a repair shop with brake fluid replacement equipment and technology to avoid air in the brake line.

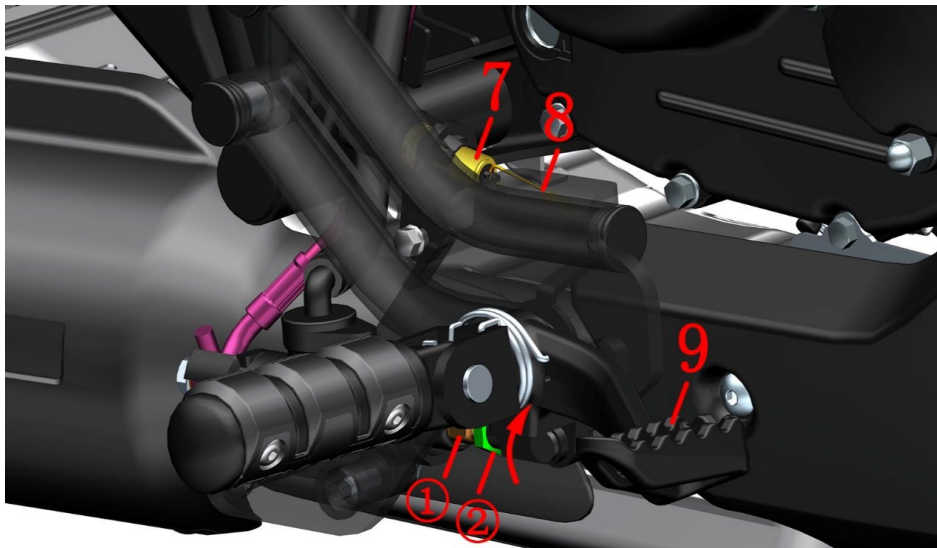
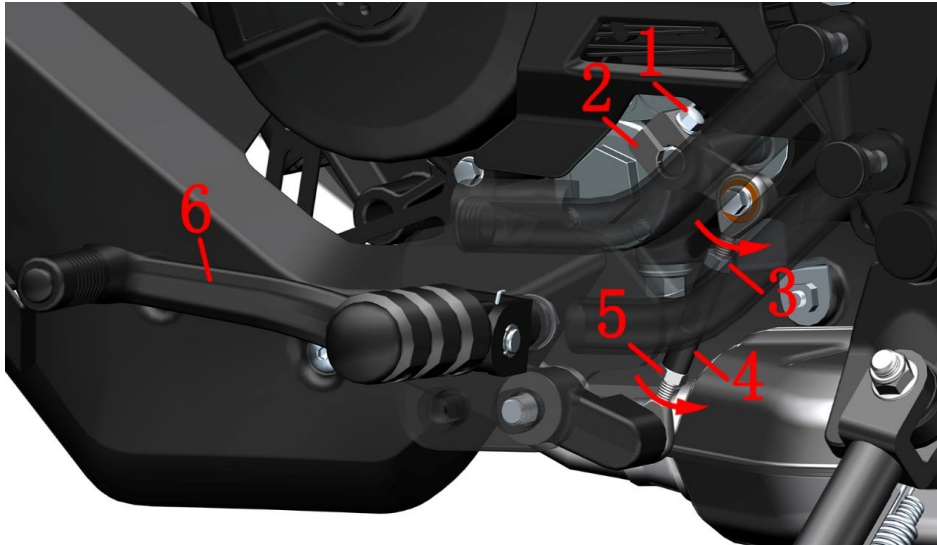

Fig.1 FOOT PEDAL COMPONENT		Adjust the hight of foot pedal	CHK	
			ADJ	
NO.	PART NO.	PART NAME	QTY	CAUTION
1	1251100-061093	M6×22 Hex flang bolt thread (8.8 garde/environmental color Zinc)	1	
2	1276500-032000	ZT250-S shift lever spline rocker arm (dumb black)	1	
3	1250301-020093	GB6170M6 (environmental color)	1	
4	1271200-233000	KD200-C adjusting screw of gear shift lever φ10×40 (Black Zinc)	1	standard
5	1250301-018093	GB6170 M6-LH(color Zinc )	1	
6	1276500-022022	KD200-C gear shift lever (dumb black)	1	
7	1186500-009000	KD20-C rear brake switch	1	
8	1100101-025000	KD20-C rear brake switch spring (A)	1	standard
9	1276500-023022	KD200-C brake pedal (dumb black)	1	

## PROCEDURE:

## ● Adjust the height of gear shift rod

Follow the direction of arrow and loosen Nut(3), Nut(5) with a 10# open spanner. Using 8# open spanner to adjust the gear shift rod adjustment bolt until the height becomes suitable. Then tighten the nuts. If the above-mentioned method can not adjust the gear shift rod to a satisfying position, take off bolt(1) and adjust gear shift rod spline of rocker arm(2) with a straight screwdriver by shoving a little bit the groove in the middle while dragging it out. Reassemble after the height is suitable. Pay attention to the aligning of the groove in the middle.

## ● Adjust the height of brake pedal

Follow the direction of arrow and loosen Nut(2) with a 14# open spanner. Spin the adjustment rod bolt(1) with a 10# open spanner and adjust the brake pedal(9) position and foot on top of the height to comfort position. Fix the adjustment rod bolt(1) and tighten Nut(2). Note that after adjusting to the position to check whether the brake light is on, if so, you need to remove the spring(8) and then rotate the brake switch(7) to the appropriate position and then re-install the spring.

## CAUTION:

- Ensure the motorcycle is well supported during manipulation. Avoid falling accident.
- The height of gear shift rod should be adjusted to a suitable range. Otherwise the riding experience would be influenced.
- The height of brake pedal should be adjusted to a suitable range. Otherwise the durance of braking shoe and plate would be influenced. In severe case, ineffective braking is possible.

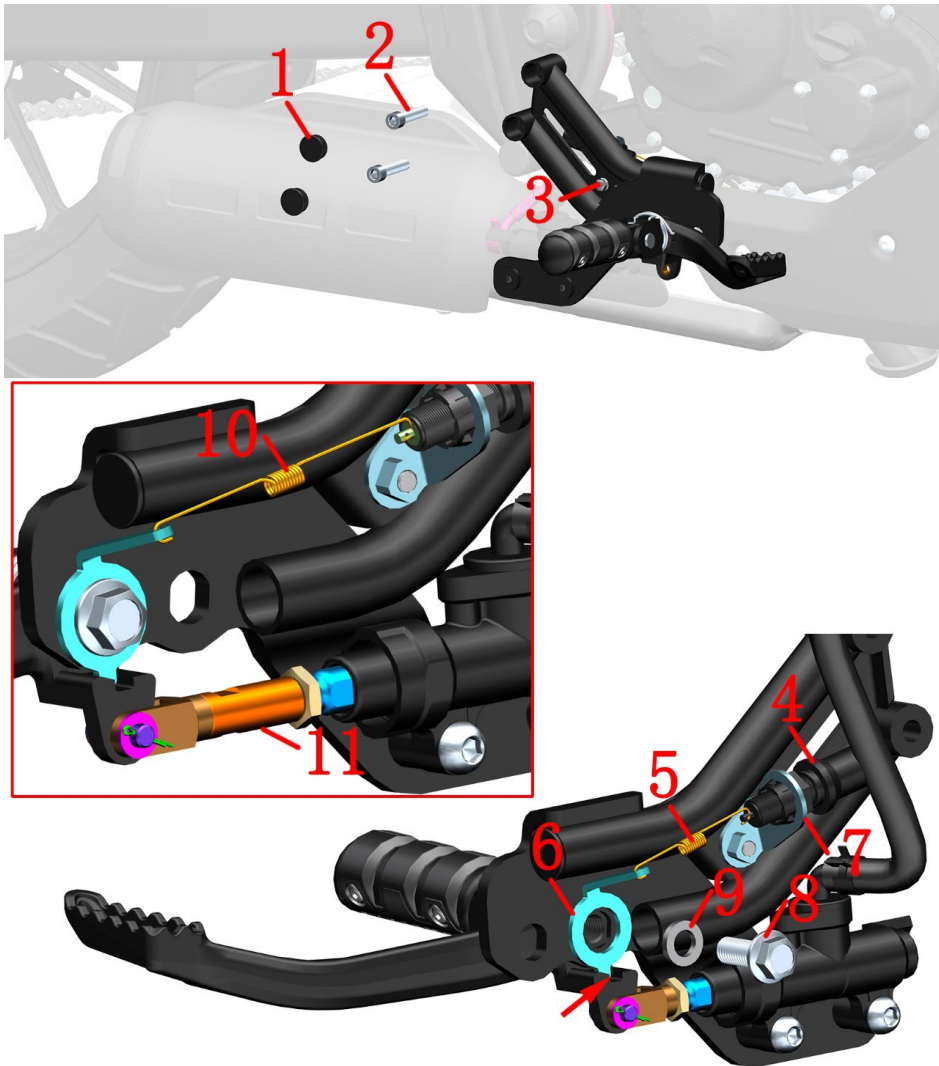
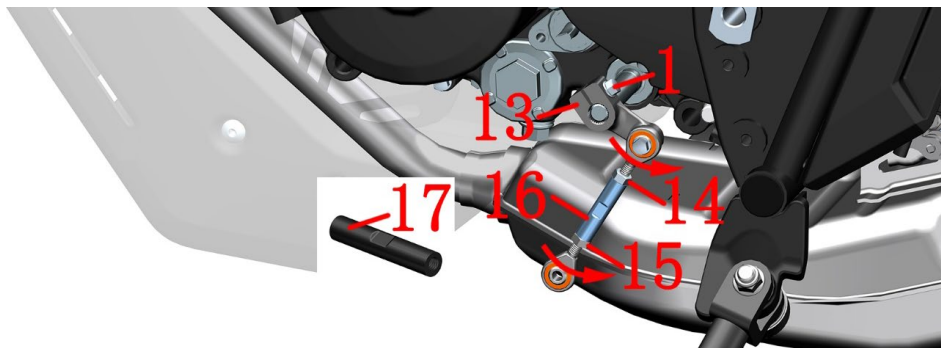
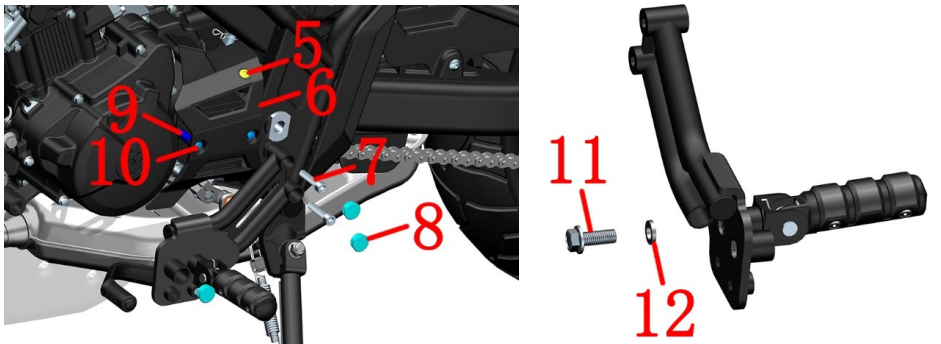
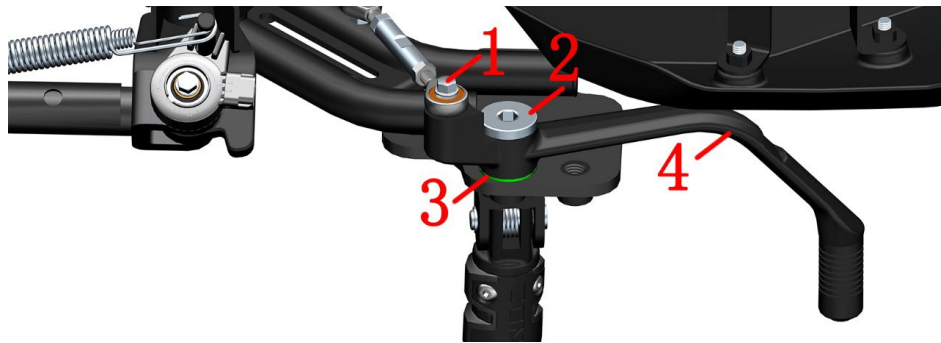

Fig.2 FOOT PEDAL COMPONENT		Front right pedal mounting position adjustment	CHK	⚠
			ADJ	
NO.	PART NO.	PART NAME	QTY	CAUTION
1	1244200-052000	ZT310 Univesral side box bracket waterproof rubber plug	2	
2	1250205-023000	GB70.1 inner hexagonal M8×35 (color Zinc)	2	
3	1250104-006097	GB16674M6×12 (chromed/HH)	1	
4	1186500-009000	KD20-C rear brake switch	1	
5	1100101-025000	KD20-C rear brake switch spring (A)	1	
6	1100101-022000	KD200-C brake switch rotation bracket	1	
7	1100101-024000	KD20-C rear brake switch bracket	1	
8	1250105-278093	GB5789 M10×1.25×25 (10.9 grade environmental protection color)	1	
9	1276500-027000	Non-standard flat pad φ10.2×φ17×2.8 (environmental color)	1	
10	1100101-026000	KD20-C rear brake switch spring (B)	1	
11	1274200-170000	ZT310-V rear brake main pump piston push rod extension rod	1	with the vehicle gift

## PROCEDURE:

- Right Foot pedal component
  - Loosen the main pump nut as described on the previous page for adjusting the brake pedal.
  - In order to facilitate the operation, here we will explain the method of removing the pedal bracket, or you can follow the steps in the manual but it will be more difficult because the operating space is narrower.
  - Remove the waterproof rubber plug(1), and remove the two bolts(2) with a 6# hexagonal socket. Grasp the rear brake switch bracket and remove the bolt(3) with an 8# socket.
  - Flip the footrest bracket assembly over to the back. Remove the rear brake switch spring(5) from the switch (4).
  - Remove the circlip, pads and pin that came with the rear brake main pump.
  - Remove the rotation bracket(6) and pad(9) after removing the bolt(8) with a 14# socket.
  - Install the complimentary extension after removing the U-joint and screw it onto the main pump adjusting screw without locking the nut first.
  - After moving the right foot pedal assembly with the brake pedal forward one hole, put back the bolt(8) and the rotation bracke(6) and pad(9). Note that the rotation bracket needs to snap into the groove of the brake pedal and the bolt(8) needs to be coated with thread tightening glue.
  - Put back the circlip, pad and pin that come with the rear brake main pump.
  - Replace the brake switch spring with an extended spring(10) and put it back on the brake switch. Install the bracket(7) back onto the footrest bracket with the bolt(3). Install the pedal bracket assembly back onto the frame and plug the rubber plug.

Adjust the brake pedal as described on the previous page, and lock the nut that comes with the main pump when it is properly adjusted.



After reinstalling all the parts in place, adjust the shift lever according to the steps and then lock the nuts (14) and (15).

Fig.3 FOOT PEDAL COMPONENT		Front left pedal mounting position adjustment	CHK	CAUTION
			ADJ	
NO.	PART NO.	PART NAME	QTY	
1	1251100-061093	M6×22 Hex flang bolt thread level 8.8 (color zinc)	2	
2	1251100-131000	Non-standard shaft position bolt M10×1.5×36	1	
3	1251500-060095	Non-standard flat padφ10.5×φ26×1(color Zinc)	1	
4	1276500-022022	KD200-C gear shift lever (dumb black)	1	
5	1224100-010000	ZT250-S swell nail	1	
6	1226500-015000	KD200-C rectifier decorative cover	1	
7	1250205-023000	GB70.1 inner hexagonal M8×35 (color Zinc)	2	
8	1244200-052000	Univseral side box bracket waterproof rubber plug	3	
9	1251700-146000	Bushing Φ12 × Φ6 × 26.5 (color Zinc)	2	
10	1251112-003093	GB16674 M6×45 Hex flange flange bolt (9.8 grade)	1	
11	1250105-278093	GB5789 M10×1.25×25 (10.9 grade/color Zinc)	1	
12	1276500-027000	Non-standard flat pad φ10.2×φ17×2.8 ( color Zinc)	1	
13	1276500-032000	ZT250-S shift lever spline rocker arm (dumb black)	1	
14	1250301-020093	GB6170M6 (environmental color)	1	
15	1250301-018093	GB6170 M6-LH(color Zinc )	1	
16	1271200-233000	Adjusting screw of gear shift lever φ10×40	1	
17	1271200-235000	Adjusting screw of gear shift lever φ10×50	1	gift of vehicle

PROCEDURE:

● Left Foot pedal component

In order to facilitate the operation, here we will explain the method of removing the pedal bracket, or you can follow the steps in the manual but it will be more difficult because the operating space is narrower.

Remove the bolt(1) with an 8# socket, remove the bolt(2) with an 8# hexagon socket, remove the pad(3), and remove the shift lever(4).

Remove the swell nail(5), remove the two bolts(10) with an 8# socket, and then remove the rectifier decorative cover(6) and the two bushings(9).

Remove the three pieces of waterproof rubber plugs(8), and remove the footrest bracket assembly by removing the two bolts(7) with a 6# socket. Remove the bolt(11)with a 14# socket, remove the pad(12) and then install the footrest assembly one hole forward. After the pad(12) and bolt(11) back, note that bolt(12) need to apply the appropriate amount of thread tightening glue to prevent loosening.

Use 8 # open-end wrench to fix the notch in the middle of the adjusting screw, and then use 10 # open-end spanner to loosen the nut (14)and nut(15) in the direction of the arrow, and then remove the adjusting bolt and replace it with the lengthening screw supplied with the vehicle. Pay attention to both ends of the screw into the same length as far as possible, do not lock the nut first.

Remove the bolt(1) at the engine gearshift shaft with the 8# plum wrench, rotate the spline rocker arm(13) clockwise by 1 to 2 teeth, do not turn more than one to avoid the subsequent difficulty in adjusting the angle of the gearshift lever, result to reassemble again.

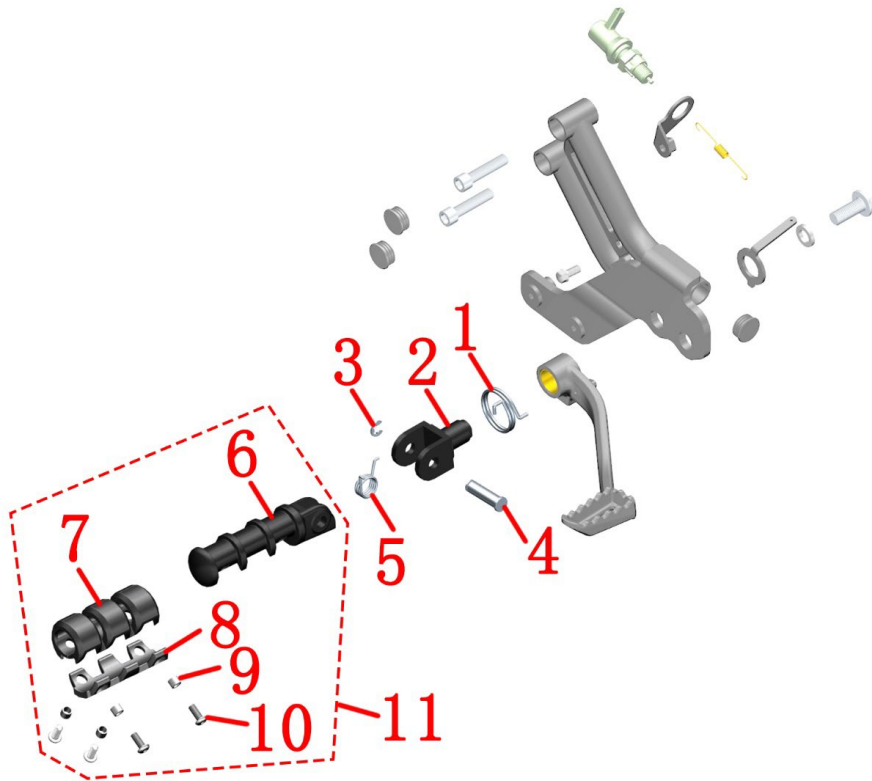

Fig.4 FOOT PEDAL COMPONENT		Right footrest component	CHK	
NO.	PART NO.	PART NAME	ADJ	
1	1271200-234000	KD200-C brake pedal spring(environmental color Zinc)	1	CAUTION
2	1274200-346021	ZT310-R Foot Support (M10/dumb black)	1	
3	1264100-006000	ZT250-S Pedal circlip	1	
4	1274100-012000	ZT250-S Pedal pin	1	
5	1264100-004000	ZT250-S front right foot pedal torsional spring	1	
6	1276500-037022	ZT310-V Rear left foot applique (dumb black)	1	
7	1244200-063000	ZT310-V front pedal rubber cover	1	
8	4066500-012022	ZT310-V front pedal press block (matte black)	1	
9	1251700-117000	Bushing $\Phi$ 7.4 x $\Phi$ 5.4 x 5.7	4	
10	1250205-038000	GB70.2M5x12 (stainless steel)	4	
11	4066500-009022	ZT310-V front right foot pedal assembly (dumb black/MES)	1	

## PROCEDURE:

## ● Right Foot pedal bracket component

The brake pedal, brake switch, etc. can be removed by following the steps in "Front Right Pedal Bracket Mounting Position Adjustment" and will not be repeated here. The rear brake main pump can be removed from the bracket by following the steps in "ABS Brake System A-3" in the Front Fork Assembly section, which will not be repeated here.

## ● Right Foot pedal component

Remove the torsion spring(1).

Remove the circlip (3),after taking off pin (4), separate the pedal bearing (2), torsion spring (5) and front right pedal assembly (11).

Remove 4 pieces bolts (10) by 3# inner hexagon, and take off 4 bushings (9).

Take off the pedal pressure block (8).

Take off the pedal rubber sleeve(7) from the pedal(6).

## CAUTION:

● Support the motorcycle properly while disassembling in case it falls down.

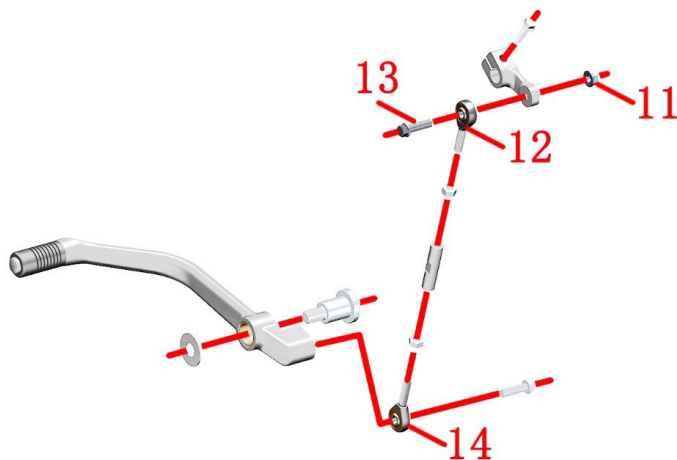
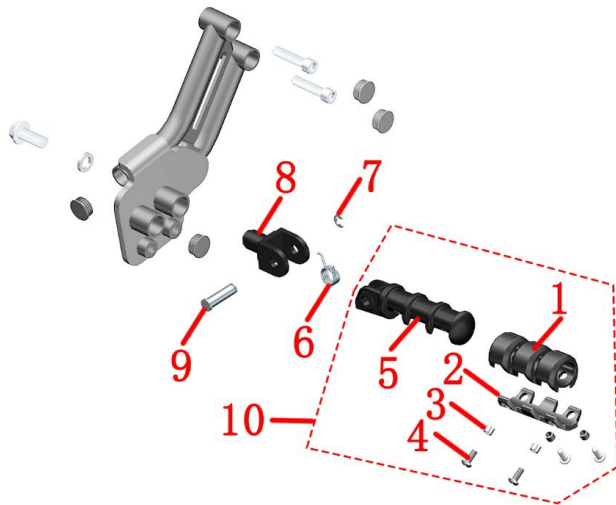



Fig.5 FOOT PEDAL COMPONENT		Left footrest component	CHK	
NO.	PART NO.	PART NAME	ADJ	
1	1244200-063000	ZT310-V front pedal rubber cover	QTY	CAUTION
2	4066500-012022	ZT310-V front pedal press block (matte black)	1	
3	1251700-117000	Bushing $\Phi$ 7.4 x $\Phi$ 5.4 x 5.7	1	
4	1250205-038000	GB70.2M5x12 (stainless steel)	4	
5	1276500-036022	ZT310-V Front left foot applique (dumb black)	1	
6	1264100-003000	ZT250-S front left foot pedal torsional spring	1	
7	1264100-006000	ZT250-S Pedal circlip	1	
8	1274200-346021	ZT310-R Foot Support (M10/dumb black)	1	
9	1274100-012000	ZT250-S Pedal pin	1	
10	4066500-008022	ZT310-V front left foot pedal assembly (dumb black/MES)	1	
11	1250303-010093	GB6177.1M6 (environmental color)	1	
12	1274100-042000	Miniature rod end ball bearing SAJK6C	1	
13	1251100-061093	M6x22 Hex flang bolt thread level 8.8 (color zinc)	1	
14	1274100-043000	Miniature rod end ball bearing SAJK6C	1	

## PROCEDURE:

## ●L, Foot pedal bracket component

The shift lever, pedal assembly, spline rocker arm and adjusting screw can be removed by following the steps in "Adjusting the Front Left Pedal Bracket Mounting Position", which will not be repeated here.

Remove the left footrest assembly by following the steps in "Removing the right footrest assembly" on the previous page, which will not be repeated here.

## ●Gear shift rod assembly

If you need to replace the Miniature rod end ball bearing SAJK6C (12), secure the bolt(13) with an 8# socket and remove the nut(11) with a 10# socket.

## CAUTION:

- Applying lubrication to the surface of cylinder of foot pedal holder can reduce resistance on gear shiftrod.
- Pay attention to distinguishing the nuts at both ends of the knuckle bearing and the adjustment screw.
- Ensure correct installation when exchanging after sales components of the pedal.

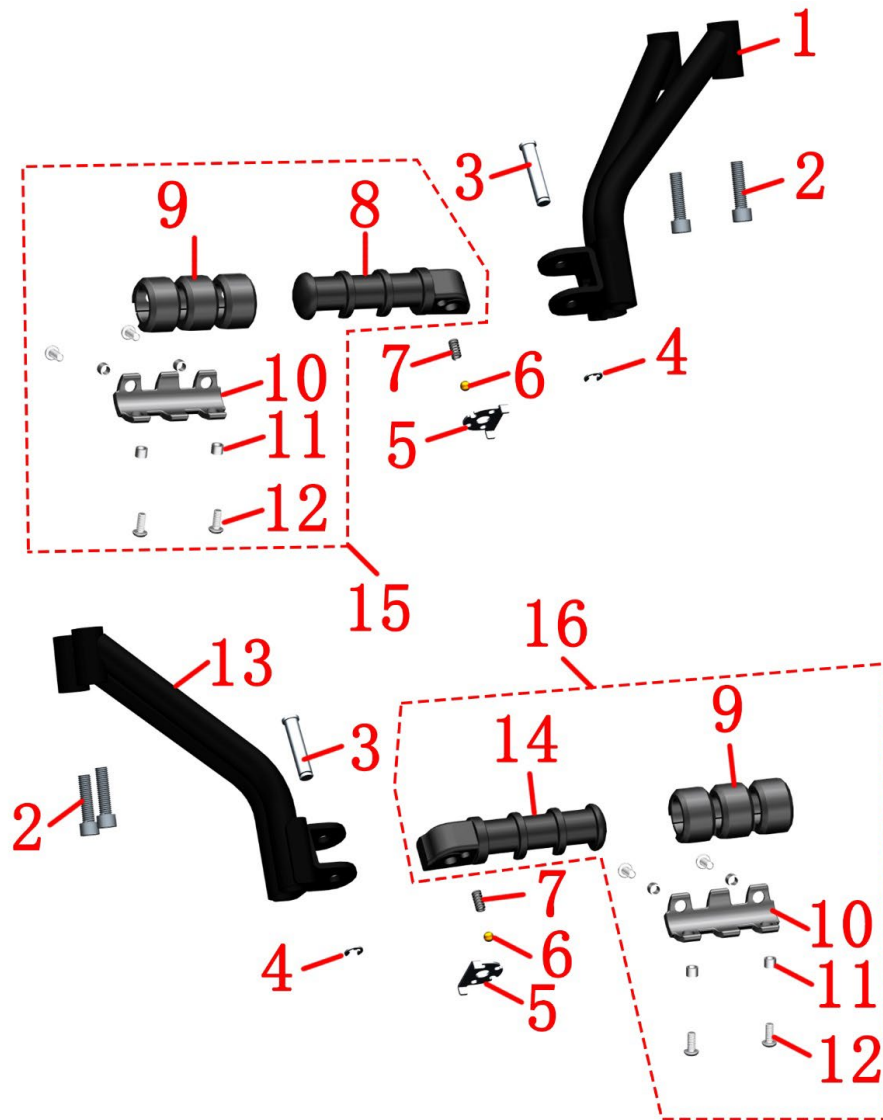

Fig.6 FOOT PEDAL COMPONENT		Rear footrest component	CHK	CAUTION
			ADJ	
NO.	PART NO.	PART NAME	QTY	
1	4066500-003000	KD200-C rear left pedal bracket	1	
2	1250205-034093	GB70.1 inner hexagonal M8×30 (color Zinc)	4	
3	1274200-335000	ZT310-R pedal pin (total length 43mm)	2	
4	1264100-006000	ZT250-S Pedal circlip	2	
5	1274300-032000	ZT350-R rear pedal locating plate	2	
6	1274300-031000	ZT350-R rear pedal steel ball(6.35)	2	
7	1260100-301000	ZT350-R foot pedal steel ball spring	2	
8	1274200-347021	ZT350-S rear left pedal (dumb black)	1	
9	1244200-063000	ZT310-V front pedal rubber cover	2	
10	4066500-012022	ZT310-V front pedal press block (matte black)	2	
11	1251700-117000	Bushing Φ 7.4 x Φ5.4 x 5.7	8	
12	1250205-038000	GB70.2M5×12 (stainless steel)	8	
13	4066500-004000	KD200-C rear right pedal bracket	1	
14	1274200-348021	ZT350-S rear right pedal (dumb black)	1	
15	4066500-013022	ZT350-S rear left foot pedal assembly (matte black)	1	
16	4066500-014022	ZT350-S rear right foot pedal assembly (matte black)	1	

## PROCEDURE:

## ●L, Foot pedal component

After removing the circlip(4), remove the pin(3) and remove the rear left foot pedal assembly(15), locating plate(5), ball(6) and spring(7). Remove the left footrest bracket assembly from the vehicle after removing the two bolts(2) with a 6# hex.

## ●Foot pedal with rubber for after sales service

Remove 4 pieces bolts (12) by 3# inner hexagon, and take off 4 bushings (11). Take off the pedal pressure block(10). Take off the pedal rubber sleeve(9) from the pedal(8).

## ●R, Foot pedal component

Refer to the steps above to disassemble the rear right footrest assembly.

## CAUTION:

- Need to apply a proper amount of thread fastening glue to the head of the bolts(12).
- Pay attention to distinguishing the nuts at both ends of the knuckle bearing and the adjustment screw.
- Ensure correct installation when exchanging after sales components of the pedal.



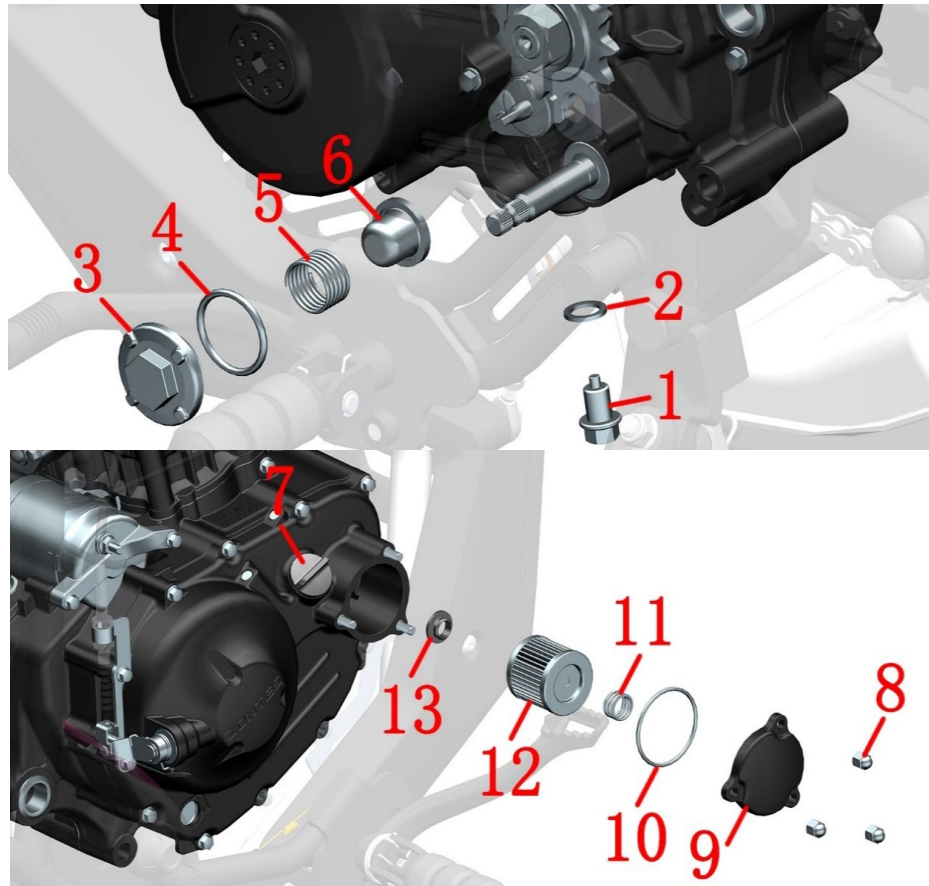



Fig.1 COOLING SYSTEM COMPONENT		Change the oil and the oil filter		CHK	
				ADJ	
NO.	PART NO.	PART NAME	QTY	CAUTION	
1	1251100-066093	M12×1.5×15 oil drain bolt (color zinc)	1	30±3N·m	
2	1244100-033000	Combined sealing gasket 12×φ20×2	1		
3	4050968-003000	ZT1P58MJ coarse filter cover (pottery)	1	32±1.5N·m	
4	1051468-003000	34.5×3.5 acrylate adhesive O—ring	1		
5	1050868-003000	Φ25.8×34.2×1.8 coarse filter spring	1		
6	1050868-004000	Outer diameter φ22×21 hat—shaped coarse filter	1		
7	1251300-054000	M20×1.5 fuel filler cap	1		
8	1251300-096000	Non-standard cover type 9 degree nut M6×13	3		
9	4050456-008051	ZT158MJ oil filter cover (dark gray)	1		
10	1051456-007000	φ49×φ2.5 Acrylic O-ring	1	after-sales	
11	1050868-002000	Φ18.5×13×1.6 fine filter spring	1		
12		Fine filter seal assembly(carton packaging)	1	<b>【1】</b>	
13	1051466-016000	ZT152QMI oil fine filter seal	1	after-sales	

## PROCEDURE:

## ● Drain the engine oil

Park the motorcycle with side stand on flat ground. Place holder to collect wasted engine oil under the oil drain bolt.

Using 14# sleeve+ratchet wrench remove the oil drain bolt(1) and the combined sealing gasket(2), Unscrew the oil filler nut (7) on the right side to speed up the oil outflow.

Using 24# sleeve+ratchet wrench remove the coarse filter cover component, take off the spring(5), and the strainer(6). Take off the O-ring(4) from the coarse filter cover(3).

Use a clean non-woven cloth to wipe off the oil stains on the surface of the coarse filter and the joint surface. After correctly assembling all the parts above except the oiler nut, proceed to the next step.

## ● Change engine oil filter

Place holder to collect wasted engine oil under right crankcase cover. Using 10# sleeve remove nuts(8), take off the oil filter cover component、fine spring(11)、oil filter(12) and filter seal(13). Take off the O-ring(10) from the oil filter cover(9). Wipe off the grease with a clean non-woven cloth and replace with a new fine filter sealing assembly (including fine filter, O-ring and sealing ring), and restore all parts.

## ● Change engine oil

Add from opening on right crankcase of engine 1.0L (If replacing the oil filter element with 125/155cc, add 1.05L, and add 1.1L with 200cc.) new engine oil of SAE 5W-40/10W-50/10W-40 with API SN degree or higher. Then reassemble the fuel filler cap(7). Start the engine and test it under different rotation speed for 2 minutes. Check if the engine oil leaks. Run the engine at idling speed for 5 minutes then shut down the engine for 3 minutes. Check the engine oil level gauge.

## CAUTION:

- Wasted engine oil should be collected and hand over to qualified facilities for further treatment. Do not pour the oil anywhere and avoid pollution of environment and water source.
- Disassembling the cooling system while the motorcycle is hot is prohibited. Wait until the engine and muffler cool down thoroughly for the manipulation.
- Engine oil filter can not be turned over when assembling. Ensure every component is well assembled.
- **【1】** The refined filter seal component already included oil filter、φ49×φ2.5 Acrylic O-ring and ZT152QMI oil fine filter seal.

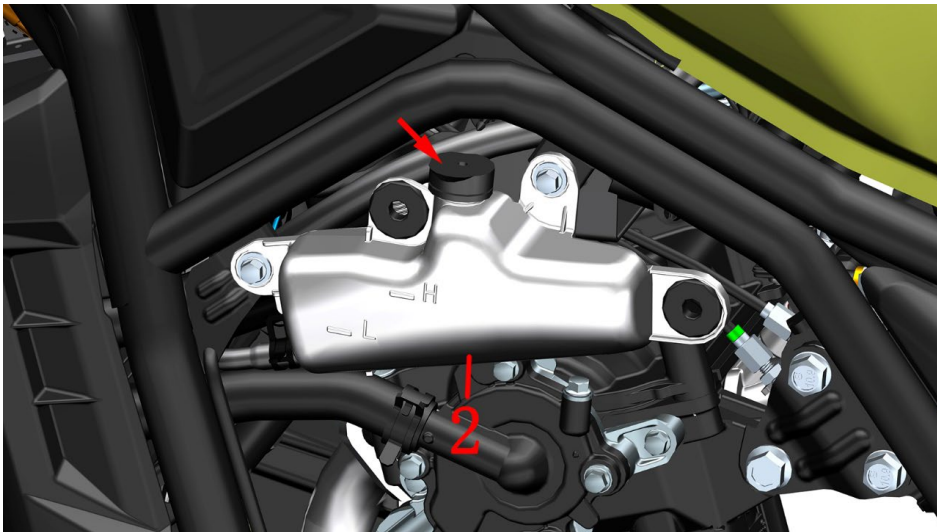
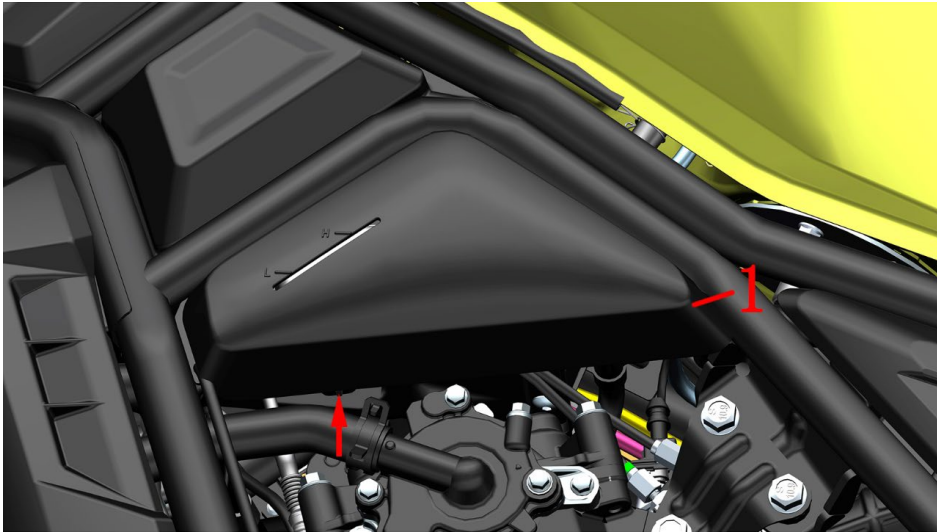

Fig.2 COOLING SYSTEM COMPONENT		Add coolant	CHK	
NO.	PART NO.		ADJ	
1	4046502-043000	KD200-C sub-tank cover part assembly (battery gasket/MES)	1	
2	1226500-002000	KD200-C auxiliary water tank	1	

**PROCEDURE:**

## ● Add coolant

When the engine is completely cooled, the vehicle can be straightened to accurately check the liquid level. If it is lower than the "L" line, the coolant should be replenished in time. If the auxiliary tank has no or only a small amount of coolant, check the cooling system first, and remove the leak before adding it.

Park the vehicle with the side brackets; turn the direction to the right and turn to the bottom.

First, break off the clips at the arrow point of the sub-tank cover, then pull out the rear part, and finally pull out the clips above the upper "H" to remove the sub-tank cover(1).

Open the lid of the auxiliary water tank(2) and add a small amount of coolant each time with a funnel. It is appropriate to reach the position between "H" line and "L" line when the liquid level of the coolant is used to support the vehicle.

**CAUTION:**

- Check regularly the cooling liquid surface. It should never be lower than "L" line.
- Change cooling liquid every two years is suggested.
- Swallowing or inhaling cooling liquid would harm human body. Clean thoroughly the hands, face or exposing skin every time after adding cooling liquid. If cooling liquid is swalled by accident, please contact toxication center or hospital. If it's inhaled, please move to open air. If it's spilt to the eye, clean it with big quantity of clean water and see doctor in time. Be sure the cooling liquid is far away from children or pets.
- Engine cooling liquid must be suitable for aluminum radiator. The basic should be glycol. Cooling liquid should be mixture of distilled water and concentrated cooling liquid under certain proportion. Be sure to choose cooling liquid which is suitable for your local extremly low temperature. The freezing point should be lower than the local lowest temperature. Distilled water is the only kind of water acceptable. Other kind of water might cause corrosion to engine cooling system or other more severe problems.
- 200CC total volume of cooling liquid is 940ml,125/155CC are 860ml.
- Cooling liquid might damage the coating of motorcycle. Be careful while adding. If it is spilt in small quantity, please clean it immediately with soft cloth.

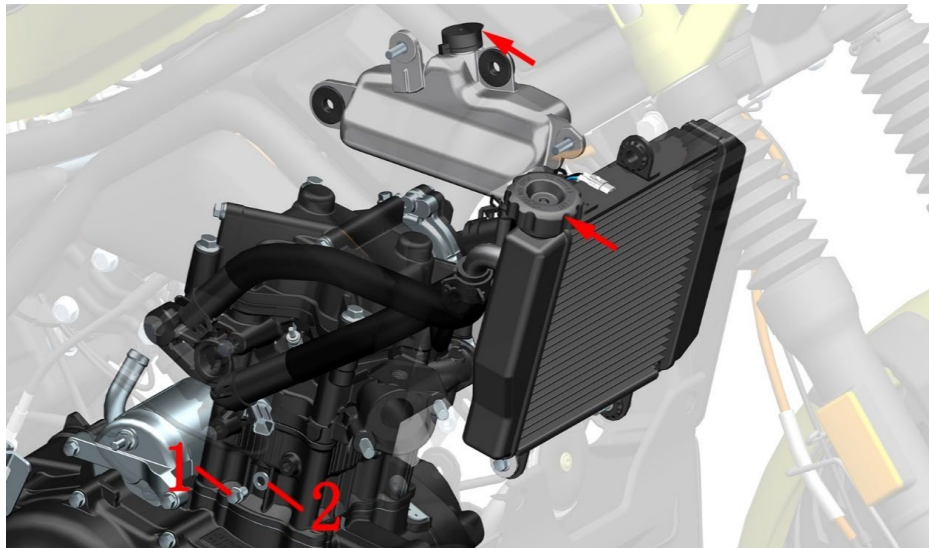

150

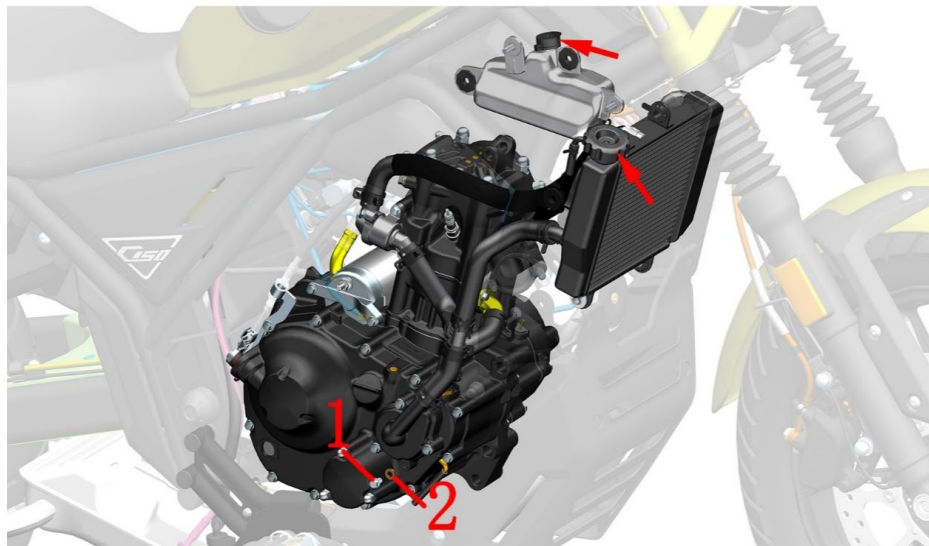

200

Fig.3 COOLING SYSTEM COMPONENT		Change coolant	CHK	
NO.	PART NO.		ADJ	
1	1251100-067093	M6×10 top pin bolt (color zinc)	1	12±1.5N·m
2	1251513-001019	6.3×12×1.6 copper gasket	1	

**PROCEDURE:**● **Drain the cooling liquid**

Cover the right crankcase cover and cylinder block of the engine with a waterproof cloth to prevent the coolant from dripping onto the cover and the engine. Wear waterproof gloves with both hands and use an 8# sleeve to remove the drain bolt (1) and remove the copper pad (2); place the container at the drain port and then open the cover of the water tank the coolant begins to drain into the container, and the body is turned to the right tilt to drain the coolant. Wipe the remaining coolant on the surface of all parts with a clean cloth, and then replace the drain bolts and copper pads. It is recommended to replace them with new bolts and copper pads.

● **Add cooling liquid**

Slowly pour new coolant into the water tank, and do not cover the cover after filling. Start the bike at idle for a few minutes and observe the liquid level. If it drops, continue to add. Repeat the operation until it is full before closing the cover. Unscrew the cover of the auxiliary water tank, add an appropriate amount of coolant to it to keep the liquid level between "H" and "L".

**CAUTION:**

- Motorcycle should be well supported.
- Manipulation should start after the engine is completely cooled down.
- Cooling liquid is toxic. Avoid strictly eye or skin contact. For more details, see "Attention" of previous page.

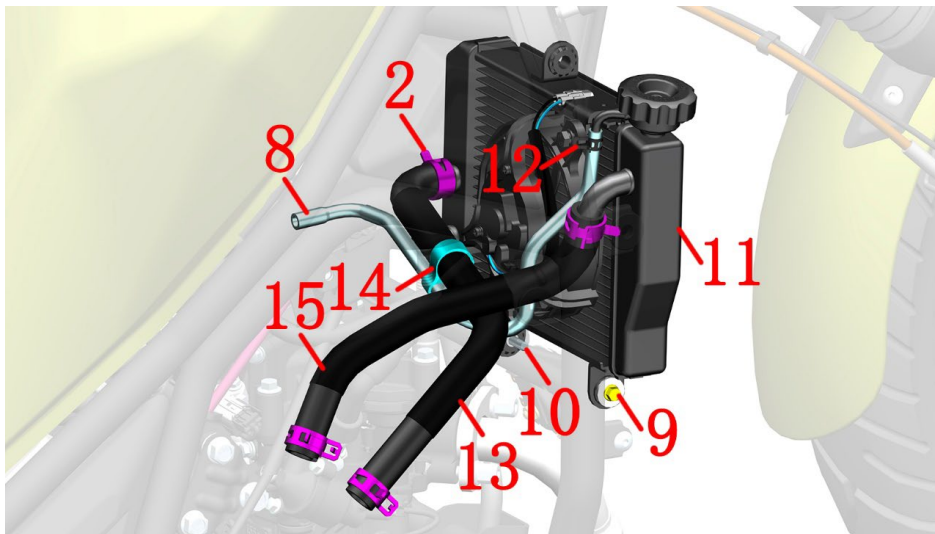
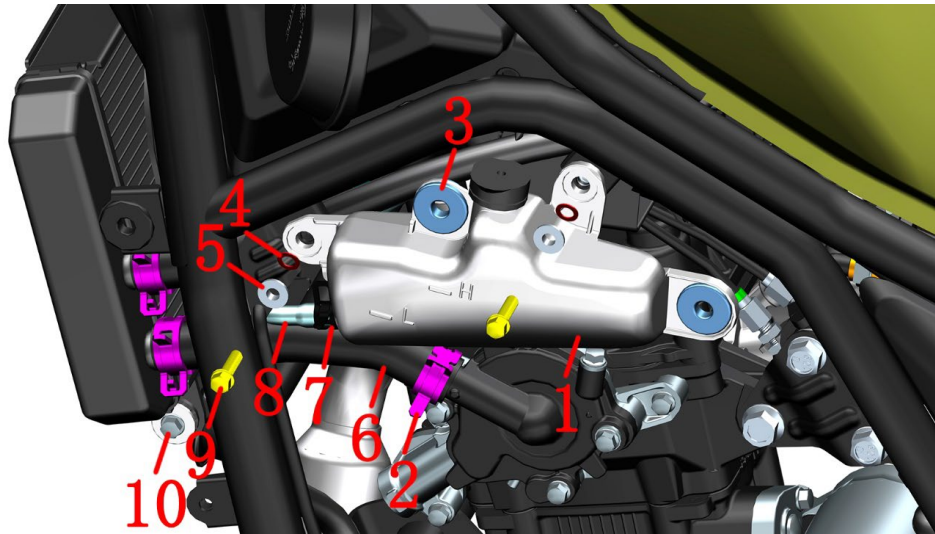



Fig.4 COOLING SYSTEM COMPONENT		Water tank component ( 125/155CC )	CHK	
			ADJ	
NO.	PART NO.	PART NAME	QTY	CAUTION
1	1226500-002000	KD200-C auxiliary water tank	1	
2	1274200-089000	ZT310 water pipe clamp ( φ22 )	6	
3	1244100-002000	ZT250-S Side cover round rubber	2	
4	1244100-052000	Buffer rubber of flanging bushing (φ8.5×φ14×1)	2	
5	1274100-057095	Flanging bushing φ6.2×φ8.4×3.5 + φ14×1.5	2	
6	1246500-023000	KD150-C engine water inlet pipe	1	
7	1274200-088000	ZT310 water pipe clamp(φ10.5)	1	
8	1246500-005000	KD200-C auxiliary water tank connecting water pipe	1	
9	1251100-061093	M6×22 Hex flang bolt thread level 8.8 (color zinc)	3	
10	1251112-002093	GB16674 M6×30 Hexagon flange bolts (color Zinc)	1	
11	1276500-017000	KD150-C main water tank	1	
12	1274200-079000	ZT310 water pipe clamp(φ9)	1	
13	1246500-024000	KD150-C small circulating water pipe	1	
14	1224300-050000	Auxiliary water tank connecting water pipe clamp	1	
15	1246500-022000	KD150-C engine outlet pipe	1	

## PROCEDURE:

## ●Auxiliary water tank

First remove the auxiliary water tank and the surround and drain the cooling liquid.

Take off the pipe clamp(14).After wearing waterproof gloves, use the hoop clamp to clamp the hoop (7) front of the auxiliary water tank and move it toward the inside of the water pipe at the same time, unplug the water pipe (8), and remove the hoop (7). Remove the hoop (12) at the water tank cover of the right water tank, and then remove the water pipe(8).

Use an 8# sleeve to remove the 2 bolts (9), take off the bushing(5) and rubber(4) that fix the auxiliary water tank(1) and then remove the auxiliary water pipe from the bike.Take off 2 pcs side cover round rubber(3).

## ●Water pipe

Remove the hoop (2) at both ends of the water inlet pipe (6) at the bottom left of the water tank and pull it out; remove the two hoop(2).

Move the bolts of the hoop (2) on the small circulating water pipe (13) on the upper left side of the water tank out of the raised part of the water pipe joint, pull out the water pipe (13) from the water tank and remove the hoop. Refer to the previous steps to remove the outlet pipe (15), as well as the 2 pieces of hoops(2).

## ●Water tank component

Use an 8# sleeve to remove the bolts (9) and (10) on the bottom of the water tank.

Locate and unplug the water tank fan and then remove the water tank assembly.

## CAUTION:

●Manipulation should start after the engine is completely cooled down.

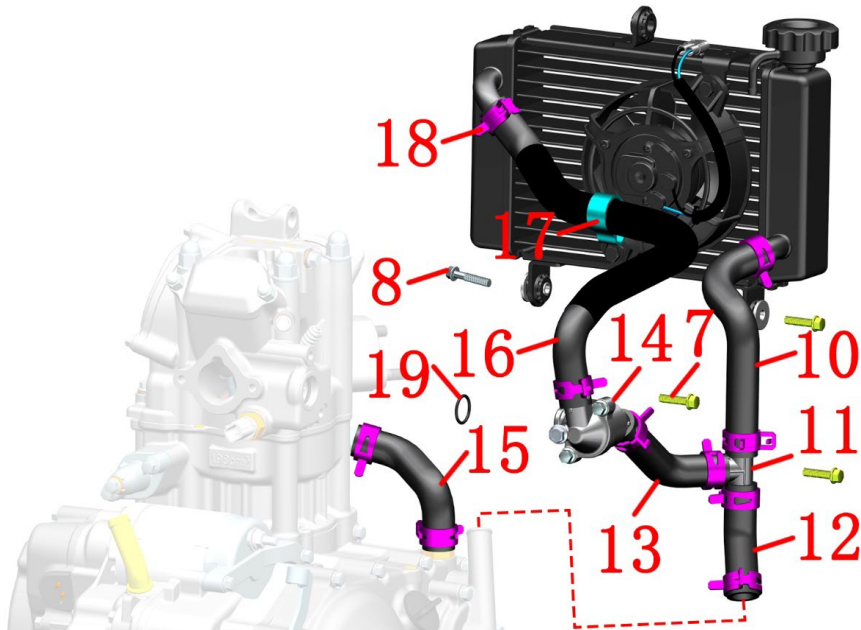
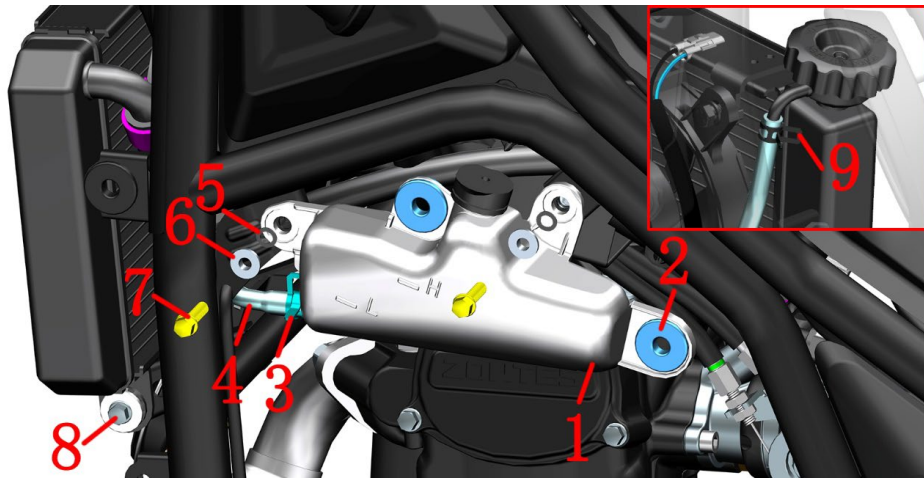

Fig.5 COOLING SYSTEM COMPONENT		Water tank component (200CC)		CHK	CAUTION
				ADJ	
NO.	PART NO.	PART NAME		QTY	
1	1226500-002000	KD200-C auxiliary water tank		1	
2	1244100-002000	ZT250-S Side cover round rubber		2	
3	1274200-088000	ZT310 water pipe clamp(φ10.5)		1	
4	1246500-005000	KD200-C auxiliary water tank connecting water pipe		1	
5	1244100-052000	Buffer rubber of flanging bushing (φ8.5×φ14×1)		2	
6	1274100-057095	Flanging bushing φ6.2×φ8.4×3.5 + φ14×1.5		2	
7	1251100-061093	M6×22 Hex flange bolt thread (8.8 color Zinc)		5	
8	1251112-002093	GB16674 M6×30 Hexagon flange bolts (color Zinc)		1	
9	1274200-079000	ZT310 water pipe clamp(φ9)		1	
10	1246500-002000	KD200-C main water tank outlet pipe		1	
11	1051968-018000	ZT1P58MJ tee		1	
12	1246500-004000	KD200-C engine water inlet pipe		1	
13	1246500-003000	KD200-C small circulating water pipe		1	
14	1271200-237000	KD200-U thermostat (matte black)		1	
15	1241200-072000	KD200-U engine water pipe		1	
16	1246500-003000	KD200-C small circulating water pipe		1	
17	1224300-050000	Auxiliary water tank connecting water pipe clamp		1	
18	1274200-089000	ZT310 water pipe clamp (φ22)		10	
19	1051468-010000	16.5×1.95 EPDM		1	

## PROCEDURE.

## ● Water tank component

First remove the auxiliary water tank and the surround and drain the cooling liquid. After wearing waterproof gloves, use the hoop clamp (3) under the auxiliary water pipe to move towards the inside of the water pipe, unplug the water pipe (4), and remove the hoop (3). Remove the hoop (9) at the water outlet of the right tank and remove the water pipe (4).

Use an 8# sleeve to remove the 2 bolts (7), take off the bushing (6) and rubber (5) that fix the auxiliary water tank (1) and then remove the auxiliary water tank. Take off 2 pcs side cover round rubber (2).

Remove the bolts (7) and (8) from the bottom of the water tank using an 8# socket.

Locate and unplug the tank fan and remove the water tank.

Move the clamp (18) of the outlet pipe (10) on the bottom right side of the water tank out of the anti-dislodgement tab and then unplug the water pipe. In the same way, pull out the small circulation water pipe (16) against the end of the main water tank and remove the clamp.

Remove the other water pipe from the tee, thermostat and engine as described above. Remove the pipe clamp (17).

If the thermostat needs to be removed then use 8# socket remove the 2 bolts (7) and pull outwards. It is recommended that the O-ring be replaced with a new one each time it is removed.

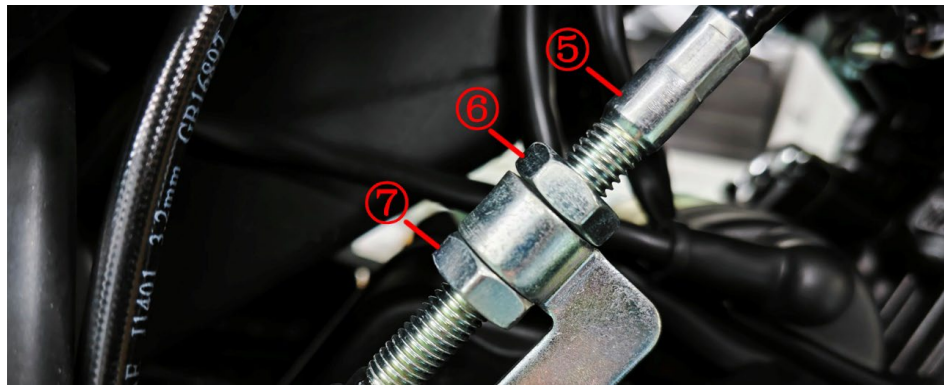

Fig.1 FRONT FORK COMPONENT		Throttle/clutch cable clearance adjustment, light height adjustment	CHK	⚠
			ADJ	
NO.	PART NO.	PART NAME	QTY	CAUTION
1	1156500-003000	KD200-C throttle return cable	1	
2	1156500-002000	KD200-C throttle refueling cable	1	
3	1156500-001000	KD200-C clutch cable	1	
4	1244200-046000	ZT310—V clutch cable sheath	1	

#### PROCEDURE:

##### ● Throttle cable

Use an 10# open-end wrench to loosen the lock nut ① on the throttle accelerating cable (2) or the return cable(1), and turn the adjustment screw ② to adjust the clearance to 0.5 to 1 mm. After the adjustment, lock the nut ① again.

##### ● Clutch cable

##### Fine adjustment:

Lift the protective rubber sleeve(4) on the clutch rocker arm to the elbow of the clutch cable(3), loosen the nut ③ with pliers, rotate the adjustment screw ④, finally lock the nut ③, and then reset the dust jacket. After adjusting, pay attention to the nut ③, the adjustment screw ④ and the groove of the rocker seat should be staggered to prevent the cable from coming out.

##### Big adjustment:

If fine adjustment cannot be achieved, using 14# open spanner loosen the nuts⑥ and ⑦, adjust the adjustment screw ⑤ location, and finally tighten the nuts⑥ and ⑦.

##### ● Light height adjustment

The rider sits in the bike and straightens the bike. Another person using 13# sleeve loosen the bolt fixed the head light,adjust the light height.

#### CAUTION:

##### ● Throttle line adjustment should be noted as follows:

After adjustment, ensure that the throttle can be reset automatically. It is forbidden to increase the idle speed of the engine due to adjustment of the cable.

The engine idle speed rise cannot occur in the direction of rotation.

Checking the engine idle speed should be performed under the condition of a heat engine.

##### ● The clutch adjustment should be noted as follows:

Excessive free travel can cause wear and malfunction of the clutch and gearshift mechanism.

After adjustment, be sure to stagger the nut, adjusting screw, and slot on the rocker arm to a certain position to prevent the cable from coming out of the slot.

##### ● Light height adjustment should be noted as follows:

Too low or too high light levels can affect safe driving. The height of the lights should be properly adjusted according to whether there are changes in the weight of the occupants and the driver.

It is forbidden to adjust the light height during riding. It is advisable to adjust the road with a smooth road surface and a straight line distance of about 150 meters without affecting traffic safety at night.

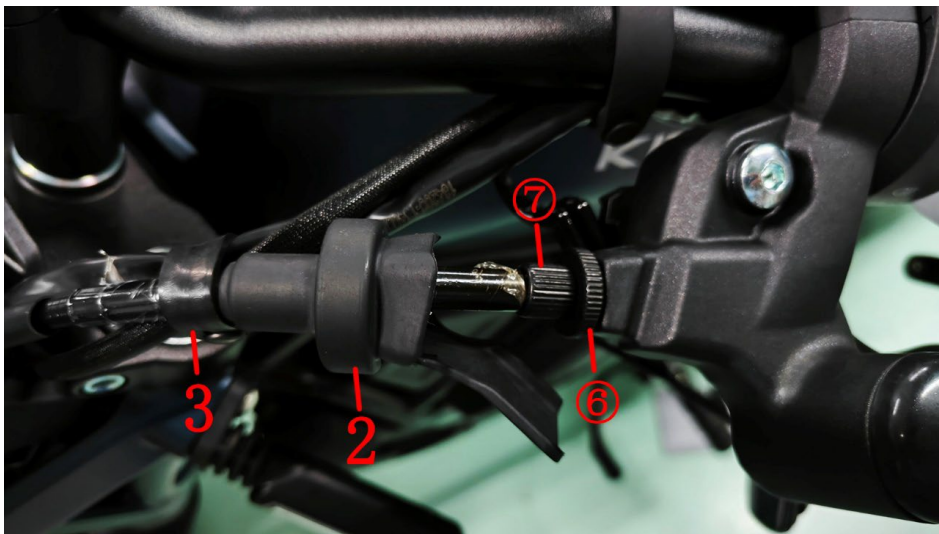
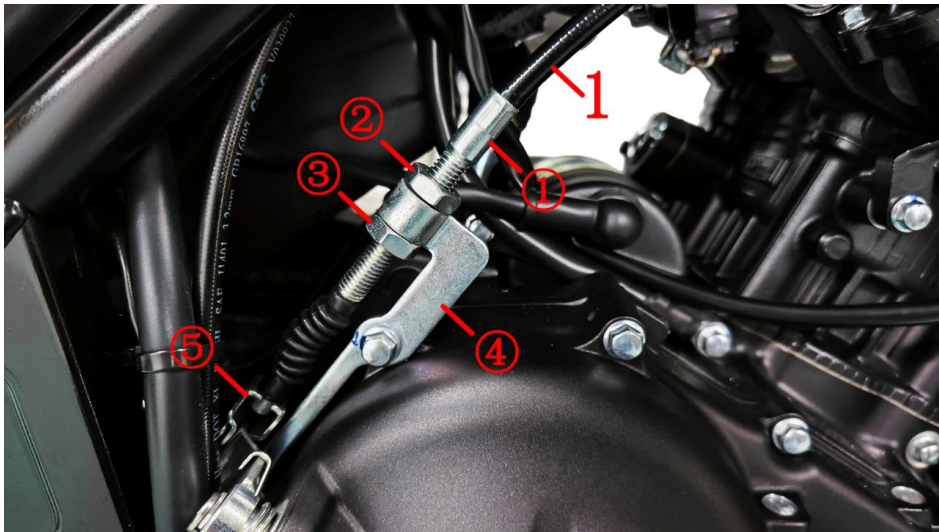



Fig.2 FRONT FORK COMPONENT		Replacement clutch cable	CHK	
NO.	PART NO.		PART NAME	
1	1156500-001000	KD200-C clutch cable	1	
2	1244200-046000	ZT310—V clutch cable sheath	1	
3	1244300-023000	ZT310 rubber buckle (50mm)	2	

#### PROCEDURE:

##### ● Remove the clutch cable

Use an open-end wrench to loosen the nuts ② and ③; fix the adjusting screw ①, rotate the nut ② up to the top of the thread of the adjusting screw, and screw the nut ③ to the bottom to completely separate from the thread. Separate the clutch wire core connector from the bracket ⑤, close the nut ③ to the black sheath with one hand, and remove the adjustment screw ① from the bracket ④ with one hand.

Remove the rubber buckle(3).

First, the protective rubber sleeve (2) is retracted to the elbow and the nut ⑥ is loosened with the pliers; the nut ⑥ and the adjusting screw ⑦ are rotated to the same position as the groove on the rocker arm, and remove the cable from the rocker arm seat.

Remove the clutch cable.

Remove the protective sleeve (2) from the clutch cable(1).

##### ● Install the clutch line

Put protective rubber sleeve (2) into clutch elbow.

After inserting the clutch line joint into the rocker arm, screw the nut ⑥ and the adjusting screw ⑦ to the groove on the rocker arm.

Assemble the clutch cable into place according to the original alignment.

Rotate the nut ② up to the top of the thread of the adjusting screw, and screw the nut ③ to the bottom to completely separate from the thread.

Take the nut ③ close to the black sheath with one hand and insert the adjustment screw ① into the bracket ④ with one hand.

Insert the clutch core connector into the hole of the bracket ⑤.

Initially position the nut ② first, adjust the free stroke adjustment in the clutch cable adjustment, and then lock the nut ③.

Finally, reset the protective rubber sleeve (2).

#### CAUTION:

● The motorcycle support should be fixed during disassembly to prevent accidents caused by incline.

● Before replacing the clutch line, it is necessary to disassemble the seat cushion, fuel tank, liner, side cover, etc.

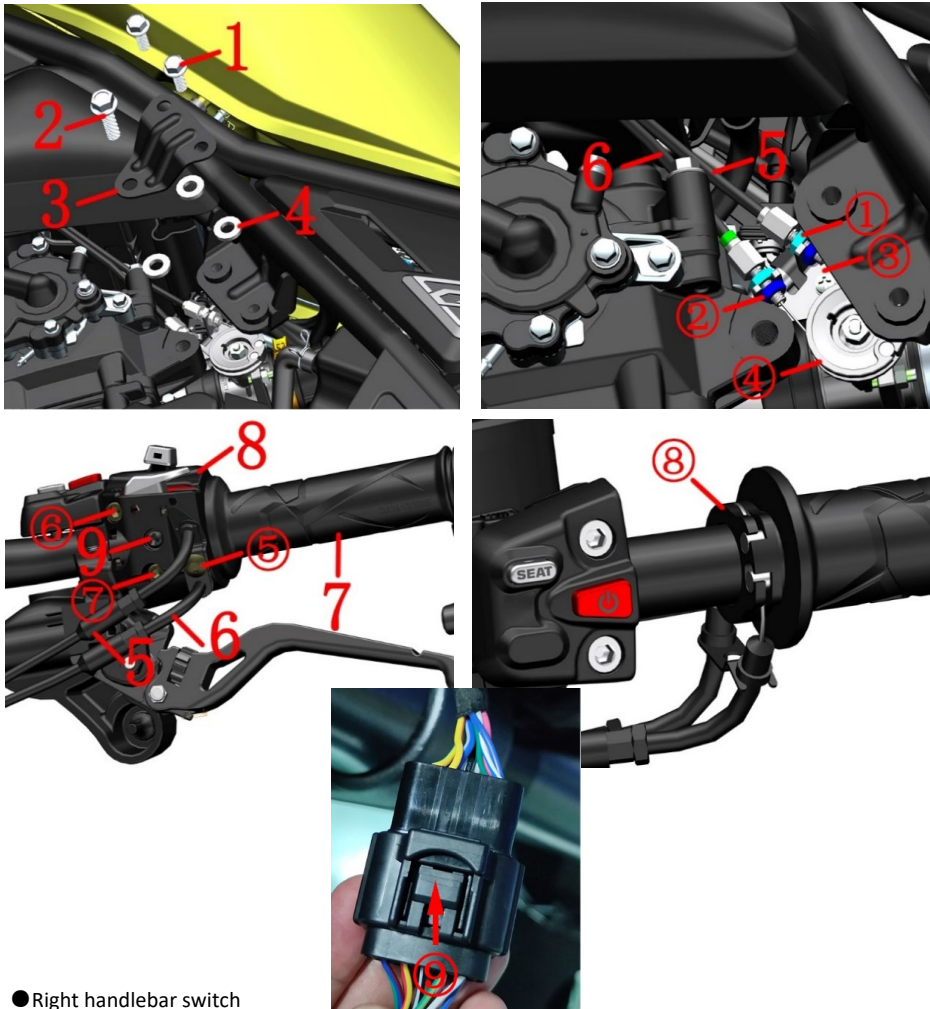

● Right handlebar switch

Press the arrow⑨ pointing to the buckle and pull out the plug of the right handlebar switch(8).

CAUTION:

- The motorcycle support should be fixed during disassembly to prevent accidents caused by incline.
- Before replacing the clutch line, it is necessary to disassemble the seat cushion, fuel tank, liner, side cover, etc.

Fig.3 FRONT FORK COMPONENT		Replace the throttle cable	CHK	⚠
			ADJ	
NO.	PART NO.	PART NAME	QTY	CAUTION
1	1251100-123093	Non-standard bolt M8×25 (color Zinc)	2	
2	1250105-144093	GB5789M10×1.25×30 (environmental color)	1	
3	4026500-012000	KD150-C hanging piece	1	
4	1251500-116000	Non-standard aluminum washer φ20×φ10×3	3	
5	1156500-003000	KD200-C throttle return cable	1	
6	1156500-002000	KD200-C throttle refueling cable	1	after-sales
7	1244100-042000	ZT250-R right handle bar rubber sleeve	1	
8	1186300-009000	ZT125T-K right handle switch (no ECO button)	1	
9	1251100-219000	Cross ball screw M5×30	1	after-sales

PROCEDURE:

● Disassemble the throttle cable

After removing the 2 bolts(1) and bolts(2) holding the hanging piece(3) on the left side with a 12# socket, remove the hanging piece and 3 pieces of aluminum washers(4).

Use 10# an open-ended wrench to screw the nut ① of the accelerator oil line (6) up to the bottom, and screw the nut ② down out of the adjusting pipe ; Remove the cylindrical joint of the oil filling line from the rotary table ④; Referring to the previous steps, first completely loosen the nuts ① and ② of the oil return line (5), remove the cylindrical joint from the rotary table, and then move the adjusting pipe of the oil return line(5) upward, over the bracket ③ on the throttle valve, and then pull it out.

Hold the right hand switch(8) with your hand and using 5# inner hexagon socket remove the bolts ⑥、⑦ and ⑤, then use a cross-signment remove the bolt(9) . Switch the upper and lower parts of the switch. Pay attention to the wiring when re-installing and can not press on any cables.

Remove the throttle cable from the right hand and remove the rubber sleeve (7) from the core turntable ⑧, and then remove it from the cable hole in the lower part of the switch.

● Install the throttle cable

First pass the throttle cable into the cable hole in the lower part of the switch. Fit the cylindrical connector of the throttle cable into the turntable ⑧ on the right hand gripper(7). Return the oil return line card to the limit slot provided on the fuel line. Use a 5#inner hexagon socket lock the bolt ⑤ to a torque of 8 to 10 Nm. The switch mounting hole is slightly twisted a few times for the rear bolt ⑥ and the bolt ⑦/(9) is locked after observing the positioning hole and the direction of the lower part of the switch (8). Finally, tighten the bolt ⑥. Reset the sub switch and rocker assembly and note the symbol on the alignment switch. Use an open hand to turn the nut ② of the throttle refueling cable (6) or the return cable (5) up to the end, and turn the nut ④ downwards to the adjustment pipe . Put the oil return line into the bracket ③, and fit the connector into the turntable . Put the oil line into the bracket ③, then turn the turntable ④ to a certain angle, and then insert the connector. Refer to the method of adjusting the gap to adjust the throttle line clearance; after adjusting the left and right direction of rotation, there should be no change in idle speed and flexible reset. Lock nuts ① and ②.



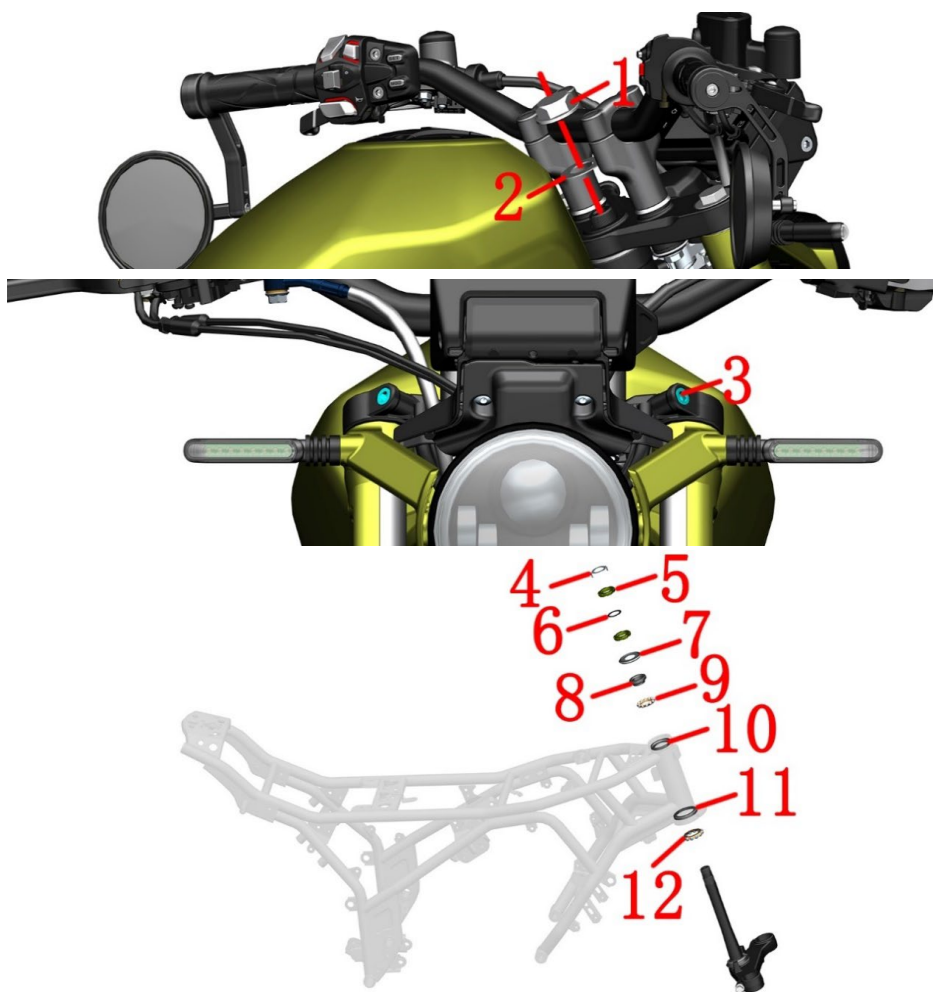

Fig.4 FRONT FORK COMPONENT		Steering adjustment	CHK	🔧 CAUTION
NO.	PART NO.	PART NAME	ADJ	
1	1251300-088000	Upper connecting plate decorative nut M22×1	QTY	100N·m
2	1251500-100000	φ22.5×φ39×1 gasket (chrome plated)	1	
3	1250205-034093	GB70.1 inner hexagonal M8×30 (color Zinc)	2	
4	1134100-007000	ZT250-S Adjusting nut locking washer	1	
5	1251300-046093	Direction column adjusting screw nut M24×1	2	
6	1244100-015000	ZT250-S Adjusting nut rubber pad	1	
7	1244300-014000	ZT350-R upper dust cover	1	
8	1130900-024000	ZT250-S shaft ring	1	
9	1130900-022000	ZT250-S conjoined steel ball	1	
10	1130900-026000	ZT250-S upper steel bowl	1	
11	1134300-001000	ZT350-R lower seat ring	1	
12	1134300-002000	ZT350-R conjoined steel ball	1	

## PROCEDURE:

●When the front fork is slightly swaying or when the direction handle is swung

Check if the pressure of the front tire is the recommended air pressure at room temperature: 215 kPa. If it is lower than the recommended air pressure, the front tire pressure should be inflated to 300 kPa first, and then deflated to 215kPa. If it is otherwise set the front wheel and turn to inspect the tire tread, if it is worn or deformed, the front tire needs to be replaced. If no, continue to operate.

●Check steering device

Set up the front wheel and shake the lower part of the fork by hand to check if the steering shaft is loose or if the left and right rotations are not flexible.

Adjust the adjustment nut:

Remove the trim nut <sup>(1)</sup> with a 30# ring spanner, remove the spacer <sup>(2)</sup>, and remove the bolt <sup>(3)</sup> with 6# inner hexagon socket. The direction of the upper board assembly wrapped with a clean cloth and then placed to prevent scratches. Remove the lock washer <sup>(4)</sup>; remove the upper adjustment nut <sup>(5)</sup> with a hook wrench and remove the pad <sup>(6)</sup>.

If the steering resistance is too large, turn the lower adjustment nut <sup>(5)</sup> counterclockwise. If the brake is slightly swaying or swings, rotate clockwise. The torque is about 14N.m. It is appropriate.

When reassembling, the top adjusting nut only needs to be screwed to align with the bottom nut groove, so as not to over-tighten to avoid excessive deformation of the pad <sup>(6)</sup>; the torque requirement of the decorative nut <sup>(1)</sup> is 100 N·m

●Steering bearing

If the above operation still can not rule out excessive steering resistance or stuck as follows:

Remove the adjusting nut <sup>(5)</sup>, remove the upper dust cover <sup>(7)</sup>, shaft ring <sup>(8)</sup>, and connecting ball <sup>(9)</sup> and <sup>(12)</sup>, remove the directional column & front shock absorber & front wheel assembly, and check the shaft ring and the connecting steel ball for abnormal wear or rust . At the same time. inspect the seat ring <sup>(10)</sup> and <sup>(11)</sup> in the

should be evenly greased, pay attention to the amount of grease.

## CAUTION:

●If the steering is adjusted too tightly, the steering force will be greater. If the steering is too loose, the front of the motorcycle will be slightly shaken during braking, and adjustments must be made according to the actual needs of the driver.

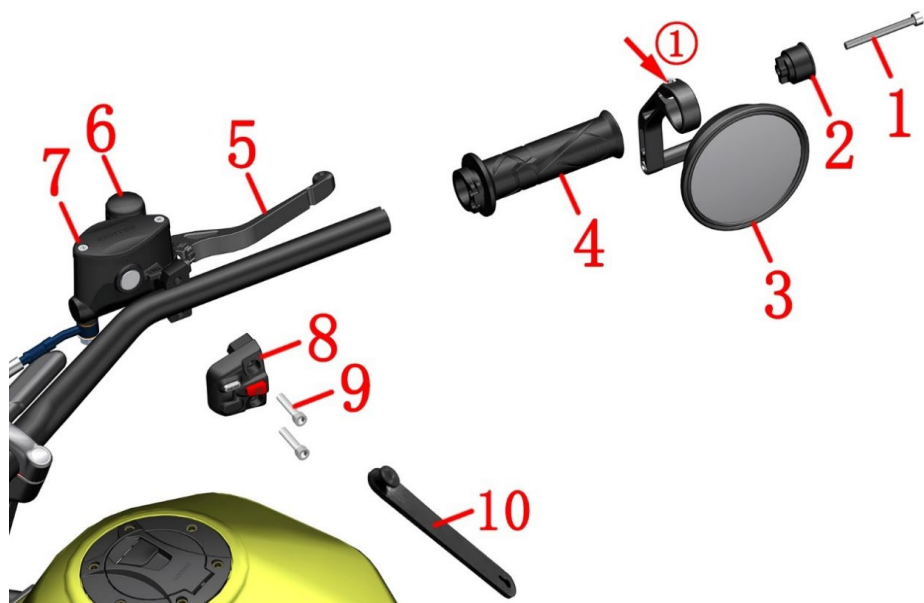

Fig.5 FRONT FORK COMPONENT		Right hand component	CHK	CAUTION
NO.	PART NO.	PART NAME	ADJ	
1	1250205-128000	GB70.1M6×60 (stainless steel)	QTY	
2	1276500-020022	KD200-C Rearview mirror mounting head	1	
3	1190100-518000	KD200-C right rearview mirror	1	
4	1244100-042000	ZT250-R right handle bar rubber sleeve	1	
5	1100101-037000	Front Brake Handle(Machining/dumb black)	1	
6	1244100-098000	ZT250-S Rearview mirror mounting hole rubber plug (matte)	1	
7	1100101-007022	KD200-C front disc brake main pump assembly (φ 12.7/without handle/matte black)	1	
8	1184300-066000	ZT350 right handlebar switch (matte black-500/without "FUEL" button)	1	
9	1250205-031091	GB70.1M6×30(stainless steel)	2	
10	1244200-138000	ZT310 rubber buckle (80mm)	1	

## PROCEDURE:

## ● Hand guard

Using 5# inner hexagon socket remove bolt(1),take off the rear view mirror holder(2).

## ● Rearview mirror,right handlebar to put rubber sleeve

Using 5# inner hexagon socket remove bolt①,take off the rearview mirror(3),then take off the rubber sleeve (4).

## ● Generation right hand switch

Find and press the snap indicated by arrow①,then take off the plug of the generation right hand switch(8).

Hold the front disc brake main pump (7) with one hand, and remove the bolt (9) with a 5# inner hexagon socket. remove the generation right hand switch (8).

Remove the rubber buckle(10).

## CAUTION:

● Remove the head part component first.

● The motorcycle should be fixed after horizontal support.

● Periodically check that the fluid level of the brake fluid is between 3/4 of the observation window.

● Do not flush the cup directly with high pressure water.

● The small spacer of the rear view mirror anti-rotation limit slot needs to be aligned with the slot on the mirror bar bolt.

● The right handlebar refers to the switch to replace the throttle line.

● The joint between the front disc brake main pump and the half cover should be aligned with the right hand to match the triangle on the switch.

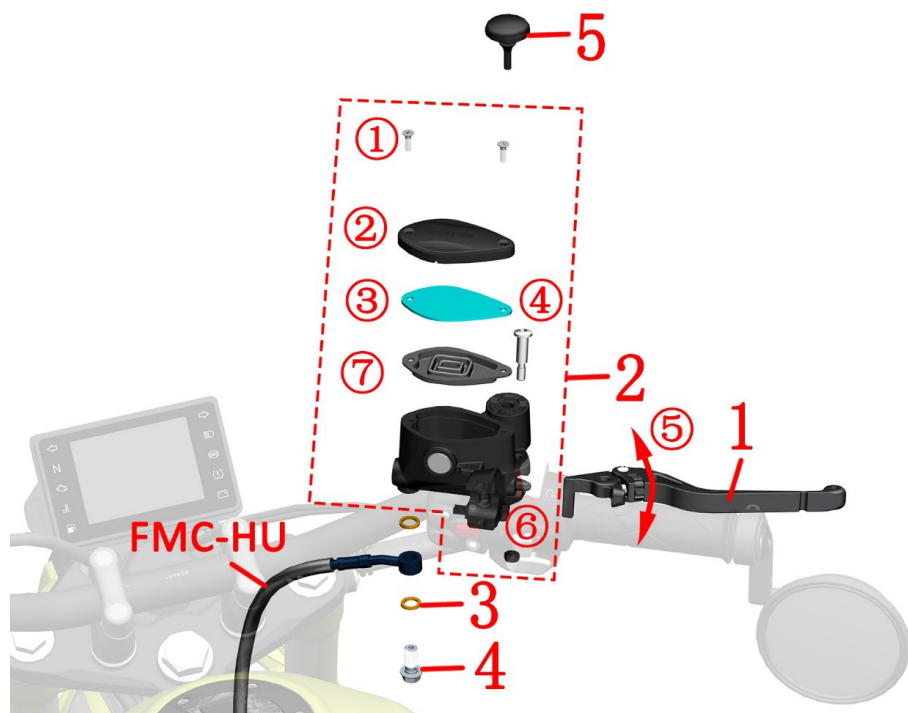
**CAUTION:**

- Periodically check that the fluid level of the brake fluid is at 3/4 of the observation window.
- If the liquid level is under "LOWER", check the brake disc wear and brake system for leaks.
- If you swallow the brake fluid, contact poison control center or hospital immediately; if you get into your eyes, seek medical attention immediately after flushing with clean water.
- Keep brake fluid away from children and pets.
- Do not flush the cup directly with high-pressure water.
- Do not mix water, dust, impurities, and silicic acid or petroleum-based liquids, as this may cause serious damage to the brake system.

Fig.6 FRONT FORK COMPONENT		Add brake fluid, rocker adjustment	CHK	
			ADJ	
NO.	PART NO.	PART NAME	QTY	CAUTION
1	1100101-037000	ZT350-GK Front Brake Handle (Machining/dumb black)	1	
2	1100101-007022	KD200-C front disc brake main pump assembly (φ 12.7/without handle/matte black)	1	
3	1251513-013000	Disc brake pipe copper washer φ 15× φ 10.2 × 1.5	2	
4	1251100-112000	Disc brake pipe bolt M10×1—22	1	32N·m
5	1244100-098000	ZT250-S Rearview mirror mounting hole rubber plug (matte)	1	

**PROCEDURE:**

## ● Front disc brake main pump

Fix the front disc brake main pump, remove the bolt (4) and copper pad (3) with a 12# sleeve, and do not disassemble if it does not need to be replaced. Always replace the tubing connector (8) at a high level to prevent air from entering the tubing and cause brake failure. Also clean oil should be removed to prevent dripping onto parts such as covers or mufflers. After replacement, be sure to continuously hold the swing arm (1) and tap the disc brake main pump (2) to remove a small amount of gas entering the brake oil circuit, and confirm that the brake is returned to normal.

● Rocker Rotating the adjusting nut (5) can adjust the distance between the rocker arm and the handle rubber sleeve to adapt to different driver's feel.

If you need to replace the rocker arm, use a 5# inner hexagon socket to fix the bolt (4). Then use a 10# sleeve or ring spanner to remove the nut (6). Remove the bolt (4) and remove the rocker arm (1).

## ● Add brake fluid

Before driving the motorcycle, check whether the brake fluid level is above the "LOWER" marking. If not, check the brake disc or brake disc for wear and whether there is any oil leakage or oil leakage in the brake system. Abnormal needs to add brake fluid.

The brake fluid can only be added after the motorcycle is fixed horizontally.

Remove the bolt (1) with a Phillips screwdriver and remove the upper cover (2), the cover plate (3), and the seal gasket (7).

Add DOT4 brake fluid to 3/4 of the transparent observation window of the front disc brake master pump. Be sure to clean the foreign body before reassembling it.

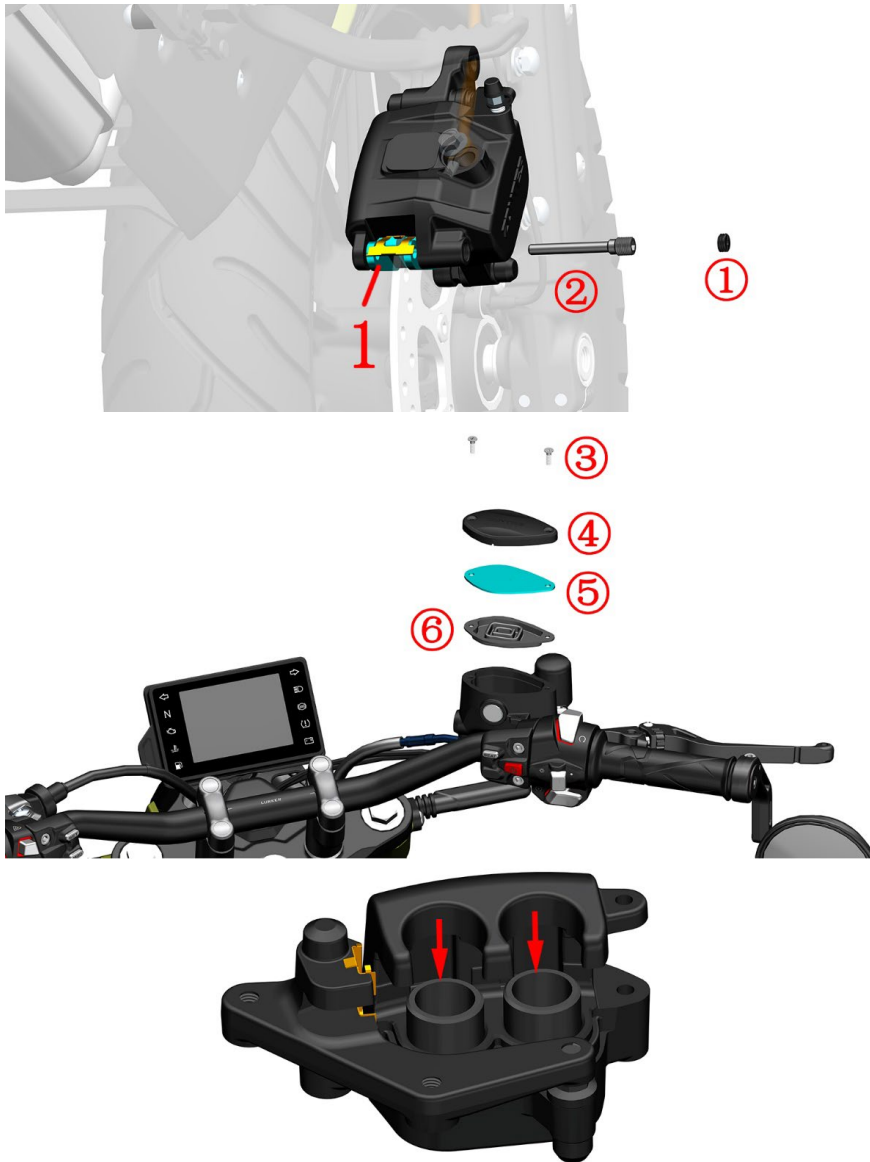

Fig.7 FRONT FORK COMPONENT		Replace the front brake pads	CHK	
			ADJ	
NO.	PART NO.	PART NAME	QTY	CAUTION
1	1100100-704000	KD150—U front disk brake piece(SF627)	1	after-sales

## PROCEDURE:

- Replace the front brake pad
  - Use a screwdriver to remove the nut ①.
  - Remove pin ② with a 5# inner hexagon socket.
  - Remove the brake pad (1).
  - Clean out foreign matter such as dust on the outer edge of the piston.
  - Use a Phillips screwdriver to remove the bolt ③ on the front brake main pump assembly, remove the top cover ④, cover plate ⑤, and seal gasket ⑥.
  - Push the piston in the direction of the arrow.
  - Restore the front disc brake main pump assembly, it must be accurately assembled in place.
  - Put a new brake pad, be sure to place the brake pad close to the card slot, as shown on the left.
  - Lock the pin ② with a 5# inner hexagon socket.
  - Use a flathead screwdriver to lock the nut ①.
  - Repeatedly holding the brake handle until braking force is restored.

## CAUTION:

- The motorcycle support should be fixed before operation.
- Check the brake discs and brake discs regularly for wear. Regularly check if the brake fluid level in the observation window of the front disc brake master pump is 3/4.
- It is strictly prohibited to disassemble the oil pipe bolts and gas discharge nozzle bolts when replacing the brake pads to prevent air from entering the pipeline and causing brake failure.
- Do not shake the front after disassembling the front brake oil cup cover to prevent the brake fluid from overflowing.
- After replacing the brake pads, the new brake pads should be operated for about 300 km to fully run in order to achieve the best braking effect. Take care to leave enough braking distance during running-in.
- It is recommended to replace brake pads in pairs with qualified maintenance units.



## PROCEDURE:

## ●Tire and wheel component

Remove the 2 bolts (1) on the left front shock absorber bottom with a 6# inner hexagon socket. Hold the front wheel first stand then remove the hollow shaft (2) with a 12# inner hexagon socket, remove the left sleeve (3), and move the front wheel component downward to remove the front wheel component. Finally, use the hexagonal tool to remove the 2 bolts (1) of the right front shock absorber, remove the right fixing sleeve (9).

## ●Brake disc, ABS ring gear

Using 6# inner hexagon socket remove 5pcs bolts(8), then take off the disc assembly(7).

## ●Tire and wheel component

Remove the Tire pressure sensor (4) built-in valve cap. Use a tool to release the air, Then use a professional tire puller to remove the rear tire (5). Be careful to avoid the tire pressure sensor. Finally, use a 2.5# inner hexagon sock to remove the bolt, then take off the pressure sensor body. Use 12# torx wrench to remove the nut and the flat washer come with the pressure sensor, and then remove the valve.

Fig.8 FRONT FORK COMPONENT		Front wheel component	CHK	⚠
			ADJ	
NO.	PART NO.	PART NAME	QTY	CAUTION
1	1250205-023000	GB70.1 inner hexagonal M8×35 (color Zinc)	4	20N·m
2	1096500-005000	KD200-C front wheel shaft Φ15×199.5	1	55N·m
3	1276500-002000	KD200-C front wheel bushing (Φ15×Φ20×18.5/ shoulder outer diameter Φ26×3)	2	
4	1184300-056000	ZT350 Tire Pressure Sensor N (M8 Elbow/120°)	1	
5	1096500-001000	KD200-C front aluminum wheel (MT2.75×16/black)	1	
6	1230100-714000	120/80-16 CM668X 60P TL E4	1	
7	1100101-021000	KD200-C front brake disc plate (300×4.5) component	1	
8	1251100-117093	Non-standard inner hex bolt M8×25 (environmental color)	5	22~24N·m
9	1096500-003000	KD200-C front wheel right fixed bushing	1	

## CAUTION:

- Use a suitable tool to support the motorcycle to prevent accidents caused by dumping during disassembly.
- Take care when disassembling tires and rims to prevent damage to the material.
- After replacing the tire, check for leaks and balance.
- Insufficient tire pressure may cause steering vibration, abnormal wear, etc.; summer tire pressure is too high there is a risk of puncture.
- Maintenance items

**Tires:** The tires should be regularly inspected for cracks, cracks, air pressure, etc. If the tread wear indicator has been worn out, the tire of the same specification type must be replaced. Refer to the relevant content of the manual for details.

**Rim:** Check the rim for any deformation, cracks, etc. Rotate the rim horizontally to check for sticking, swinging, etc. Rim seal  $\phi 20 \times \phi 42 \times 7$ ; bearing model: 6302RS.

**Axle:** Use a dial indicator to check for deformation and bending.

**Brake disc:** After replacing the brake disc, the new brake disc should be operated for about 300 kilometers to fully run in order to achieve the best braking effect. Be careful to leave enough braking distance during running-in.

- The tire repair fluid should not be used because it will block the air vent of the pressure monitoring sensor, resulting in difficulty in inflating or failure of tire pressure monitoring.

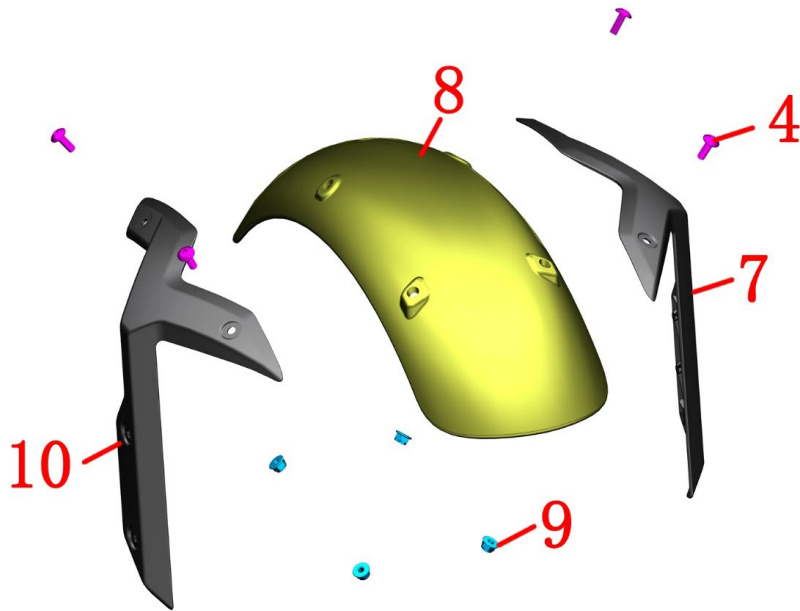
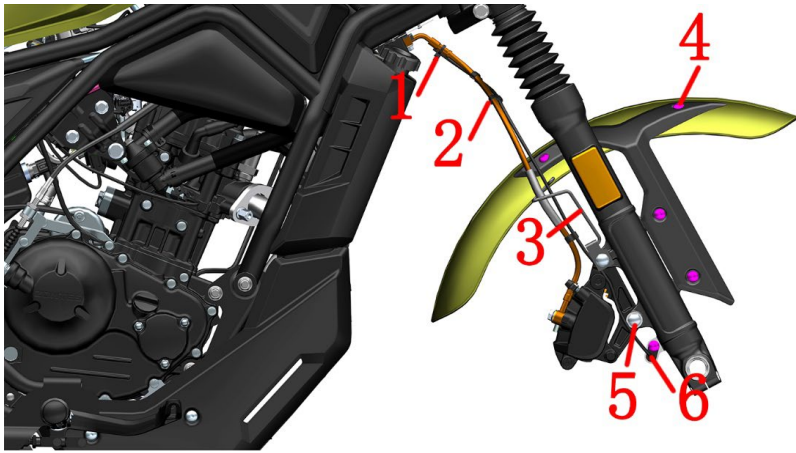



Fig.9 FRONT FORK COMPONENT		Front mud board & wheel speed sensor component	CHK	
			ADJ	
NO.	PART NO.	PART NAME	QTY	CAUTION
1	1224100-051000	0 level fire-retardant belting (black2.5×100)	1	
2	1224100-044000	Wheel speed sensor clamp	3	
3	1100100-996000	KD200-C Disc Brake Front Outlet Hose Clamps	1	
4	1251100-102000	Non-standard bolt M6×16 (304 stainless steel)	7	
5	1251100-080094	Non-standard bolt M8×37	2	25N.m
6	1181200-118000	Wheel speed sensor(A)	1	
7		KD200-C Front mud board left bracket part assembly	1	
8		KD200-C front mud board centre	1	
9	1250305-010093	GB6187.1M6 (environmental color)	4	
10		KD200-C Front mud board right bracket part assembly	1	

## PROCEDURE:

## ● Wheel speed sensor

Pull out the plug of the wheel speed sensor (6); then remove 3 pcs clamp(2). Cut off the belting(1).Using 4# inner hexagon socket remove bolt(4),take off the wheel speed sensor.

## ● Front disc brake caliper

Using 14# sleeve remove bolt(5),so that the caliper will hang down naturally. It is forbidden to invert the caliper to prevent the air from entering and causing the brake to fail.

## ● Front mud board component

Hold the front mud board component with your hand and then remove the 4 bolts(4) with a 4# inner hexagon socket and remove the front mud board component.

Using 4# inner hexagon socket fix the bolt (4),then using 10# sleeve remove the nut (9),take off the left bracket (7),middle part (8),and the right bracket(10).

## CAUTION:

● The motorcycle support should be fixed during the disassembly process to prevent accidents caused by incline.

● Disassemble the oil pipe clamp and the sensor wire clamp should pay attention to the strength.



Fig.10 FRONT FORK COMPONENT		Left hand component	CHK	CAUTION
NO.	PART NO.	PART NAME	ADJ	
1	1250205-031091	GB70.1M6×30(stainless steel)	2	
2	1184300-065000	ZT350 left auxiliary handle switch (matte black -500/no WD)	1	
3	1244100-098000	Rearview mirror mounting hole rubber plug(matte)	1	
4	1184200-184000	ZT310-V1 Left handle switch	1	
5	1244100-041000	ZT250-R left hand rubber sleeve	1	
6	1190100-517000	KD200-C left rearview mirror	1	
7	1276500-020022	KD200-C rearview mirror mounting head	1	
8	1250205-128000	GB70.1M6×60 (stainless steel)	1	
9	1251100-198000	Non-standard hexagon socket bolt M6×13-φ8×20 (env	1	
10	1134200-055021	ZT310-V clutch rocker seat assembly(matte black)	1	
11	1184200-170000	ZT310-V clutch switch	1	
12	1250201-039000	GB818 cross recessed pan head screw M4×12(color Zir	1	
13	1251300-073000	GB/T6185 hexagonal nylon lock nut M6 (environmenta	1	
14	1136500-003051	KD200-C left handle rocker arm	1	

## PROCEDURE:

## ● Left rear view mirror, left switch, hand guard

Remove the clutch line by referring to the "Replace Clutch Line" procedure. Remove the ,part(7), left rear view mirror(6),left switch(4)by referring to the steps in "Right Handle Assembly" and "Add Brake Fluid, Adjusting Rocker Arm".

Using 5# inner hexagon socket remover 2pcs bolts(1) take off the generation Left handlebar switch(2) and the left hand arm assembly(10). Press the snap indicated by arrow④,then take off the plug of the generation left handlebar switch(2),press the snap indicated by arrow⑤,then take off the plug of the left handlebar switch(4).

## ● Left hand rubber sleeve

Use a blow gun to blow the left hand grip② and the direction between the tubes.at the same time,move the left hand rubber sleeve out and remove it.Pull out the rubber plug (3).

## ● Replace the left hand rocker arm and clutch switch

Fix the bolt(9) with a 5# inner hexagon socket then remove the nut(13). Remove the bolt and remove the left-hand rocker arm(14) and the rocker arm assembly(10).

Rotate the adjusting nut③ to adjust the distance between the rocker arm and the left handle to adjust the rubber sleeve to adapt to different driver's hand feeling.

First remove the clutch switch plug, then use a cross screwdriver to remove the bolt (12), remove the clutch switch(11).

## CAUTION:

● Note the triangle symbol on the rocker arm assembly and the half cover seam alignment switch.



Fig.11 FRONT FORK COMPONENT		Directional lever component	CHK	CAUTION
NO.	PART NO.	PART NAME	ADJ	
1	4046502-016022	ZT250-S M8 bolt decorative buckle (matte black )	4	
2	1250205-034093	GB70.1 inner hexagonal M8×30 (color Zinc)	4	
3	1136500-006022	KD200-C direction clamp	1	
4	1136500-004000	KD200-C Prince direction bar	1	

**PROCEDURE:**

● Directional components

Using a blade to pick up the decorative buckles(1), hold the direction handle(4) in one hand, and remove the bolt(2) with a hexagonal tool in one hand; remove the clamp(3) and finally remove the direction handle(4).

**CAUTION:**

- Protect protective measures to prevent scratching the appearance of the instrument case and the decorative cover.
- When assembling the clamping block, first tighten the 2 bolts at the front, and then tighten the bolts at the rear (close to the fuel tank side). Wrong sequence or diagonal locking may break the lock block.



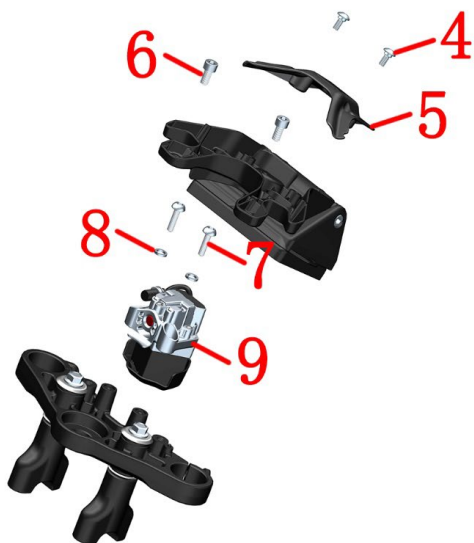

Fig.12FRONT FORK COMPONENT		Upper plate component	CHK	⚠
NO.	PART NO.	PART NAME	ADJ	
1	1251300-088000	ZT350-R Upper connecting plate decorative nut M22 × 1	1	100N·m
2	1251500-100000	φ22.5×φ39×1 gasket (chrome plated)	1	
3	1250205-034093	GB70.1 inner hexagonal M8×30 (color Zinc)	2	25N·m
4	1251100-328000	Hexagon socket head screw M6×14+8.5×3 SUS302	2	
5	1226500-016000	KD200-C Meter Bracket Baseplate	1	
6	1250205-040095	GB70.1 inner hex bolt M8×16(color Zinc)	2	
7	1251100-364000	Non-standard bolt M6×25 (environmental color/10.9 grade)	2	
8	1250501-007093	GB93 φ8 (environmental color)	2	
9	1184200-139000	ZT310 main lock (electromagnetic drive / wire length 450) assembly	1	

## PROCEDURE:

## ● Uplink board assembly

Locate the faucet lock plug and remove it; remove the nut(1) with 30# sleeve and remove the gasket(2).

Remove the upper plate bolt(3) with 6# inner hexagon socket, Insert a slotted screwdriver into the slot of the upper plates to slightly enlarge the slot clearance at both sides, and disassemble the upper plate assembly.

Flip the uplink board instrument assembly over to the backside. Remove the Meter Bracket Baseplate (5) after removing the two bolts (4) with a 4# hex. Unplug the instrument cable connector. Separate the instrument assembly from the uplink board assembly after removing the bolts (6) with a 6# hex.

Using 6# inner hexagon socket remove the faucet lock(9) and gasket(8).

## CAUTION:

● Use a flat-blade screwdriver to enlarge the gap between the upper joint plates without applying excessive force to avoid damage.

● The motorcycle support should be fixed during the disassembly process to prevent accidents caused by inline.

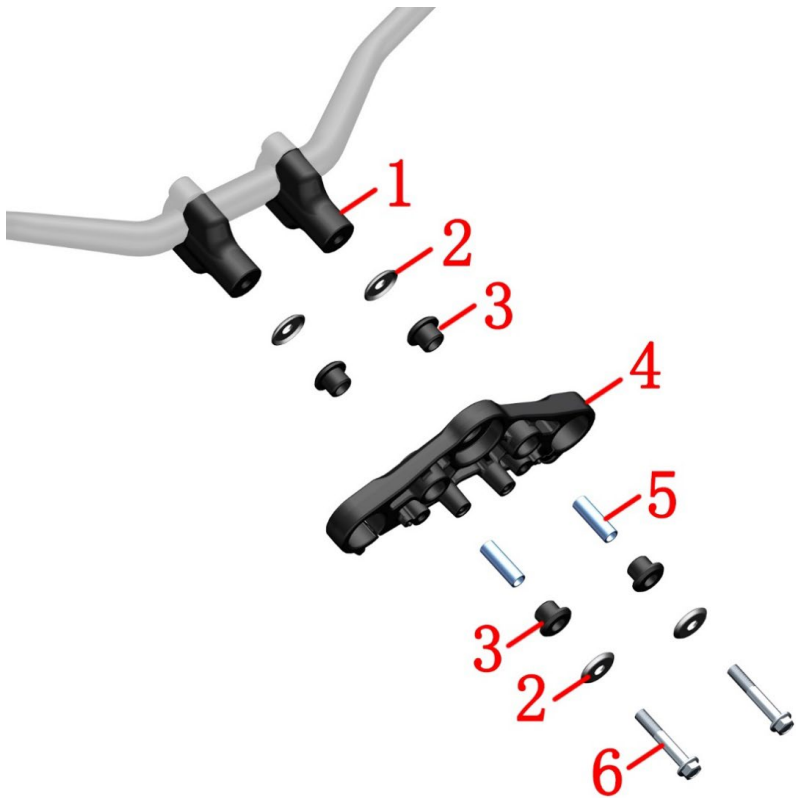

Fig.13 FRONT FORK COMPONENT		Uplink plate, direction handle block component	CHK	
NO.	PART NO.	PART NAME	ADJ	
			QTY	CAUTION
1	1136500-007022	KD200-C direction handlebar pad M10×1.25 (dumb black)	2	
2	1274200-018000	ZT310-R gasket of upper connecting board	4	
3	1246400-049000	ZT350T-D upper plate buffer glue	4	
4	1136500-001022	KD200-C upper board	1	
5	1251700-168000	ZT350T-D bushing φ10×φ13×41	2	
6	1250105-280000	GB5789 M10×1.25×60 (level 10.9 dacromet)	2	40N·m

## PROCEDURE:

## ● Uplink plate and spacer assembly

In order to facilitate the direction of the block, the direction and the upper block should be assembled first to prevent the block from rotating during the disassembly process. The direction should be wrapped with cotton or other soft materials to prevent scratching the paint surface.

Remove the bolt(6) with a 14# sleeve and remove the gasket(2), cushion rubber(3), and bushing(5).

Remove the upper plate(4).

The spacer(1), the upper clamp and the direction handle are disassembled.

## CAUTION:

● Protect protective measures to prevent scratching the appearance of parts.

● When reassembling, it is necessary to use the direction to ensure that the center and direction of the spacers on both sides are coaxial with the center. First install 4 pieces of cushioning rubber into the upper plate and then install the bushing separately. Make sure that the bushing is flush with the cushioning rubber, otherwise it should be reassembled. When tightening the nut, ensure that the torque is 40N·m. Check the buffer for spillage and reassemble if necessary.

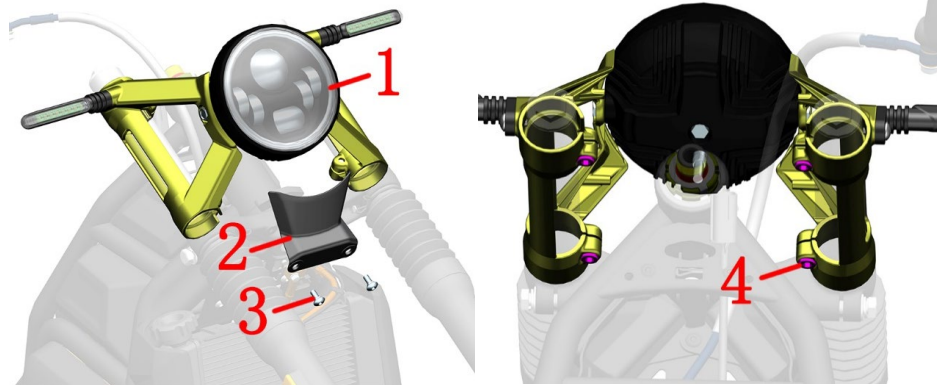
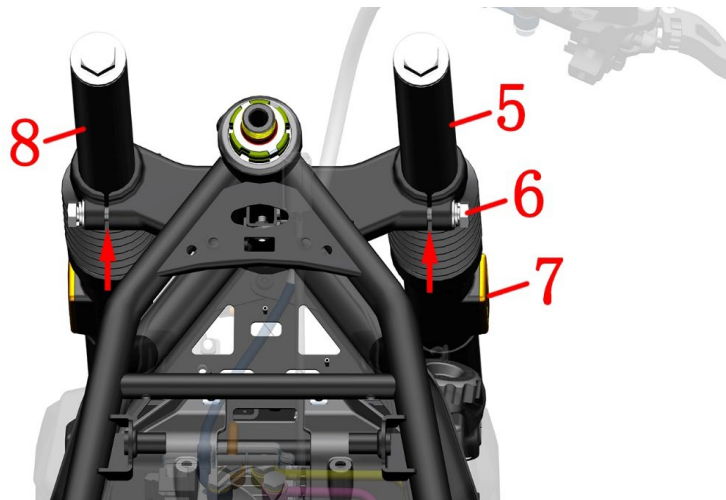

Fig.14 FRONT FORK COMPONENT		Head and headlights component 1	CHK	CAUTION
			ADJ	
NO.	PART NO.	PART NAME	QTY	
1	1176500-004000	KD200-C headlight	6	
2	1226500-017000	KD200-C headlight lower decorative cover	2	
3	1251100-328000	Hexagon socket head screw M6×14+8.5×3 SUS302	2	
4	1250205-040095	GB70.1 inner hex bolt M8×16(color Zinc)	1	
5	1116500-002000	KD200-C front right shock absorber	2	
6	1250106-071093	GB9074.17 M10×1.25×40 (environmental color)	6	
7	1174100-001000	Reflection light(KM115)	2	
8	1116500-001000	KD200-C front Left Shock Absorber	1	



## PROCEDURE:

## ● Headlight assembly

Find and pull out the plugs of the headlight and turn singanl lights .

Remove the 2 bolts (3) with 4# inner hexagon, then take off the headlight lower cover(2).

Using 6# inner hexagon remove 4 pcs bolts(4),then take off the headlight assembly.

## ● Front left and right shock absorption

Remove the bolts(6) of the lower plate with 16# sleeve , and hold the shock absorber in the middle with one hand,Insert aslottedscrewdriver into the slot of the lower plates to slightly enlarge the slot clearance, and disassemble the left shockabsorber (8) and the right shock absorber(5).Reflective sheets are sold separately for sale (no replacement shock absorption). The heat-reflecting sheet can be movedback and forth by a hot air blower to reduce the viscosity of the double-sided adhesive after being heated, and the residualglue should be cleaned after removing the reflector.

## CAUTION:

●The head unit should be supported during the disassembly process and protective measures should be taken toprevent scratching the lamp cover or paint surface.

●When assembling self-tapping screws must be perpendicular to mounting surface, otherwise it will bedamaged,and the torque should not be too large.

●When removing the shock absorption, move it in the direction of axis, do not rotate or swing to prevent scratches on thesurface.

●For the disassembly of the lower link board assembly, see the previous "steering adjustment", which will not be repeated here.

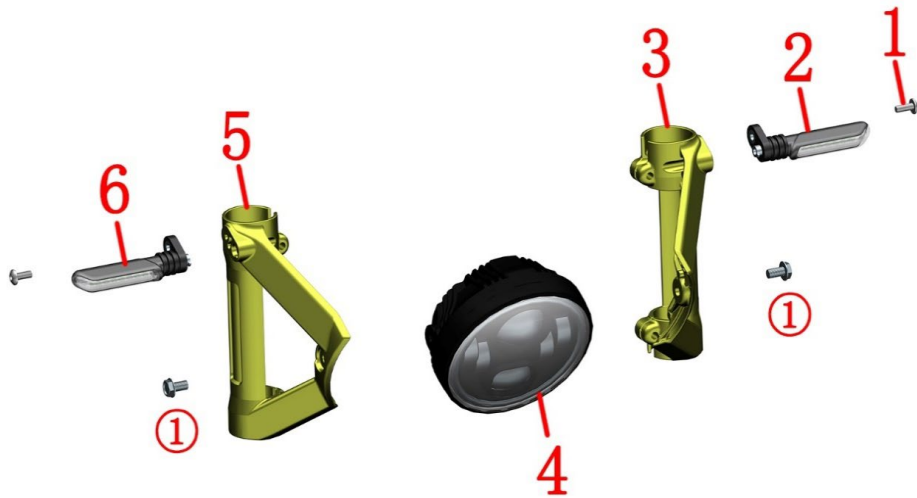



Fig.15 FRONT FORK COMPONENT		Head and headlights component 2	CHK	
			ADJ	
NO.	PART NO.	PART NAME	QTY	CAUTION
1	1251100-102000	Non-standard bolt M6×16 (304 stainless steel)	2	
2	1176500-002000	KD200-C left turn signal	1	
3		KD200-C headlight left bracket	1	
4	1176500-004000	KD200-C headlight	1	
5		KD200-C headlight right bracket	1	
6	1176500-001000	KD200-C right turn signal	1	

## PROCEDURE:

## ● Left and right turn signal components

Grasp the left (right) turn signal and use a 4# inner hexagon to remove the bolts(1), and then remove the turn signal.

## ● Left and right turn signal bracket assembly

Remove the bolts ① with the headlight with 13# sleeve, and disassemble the left turn signal bracket (3), right turn signal bracket (5).

## CAUTION:

● The head unit should be supported during the disassembly process and protective measures should be taken to prevent scratching the lamp cover or paint surface.

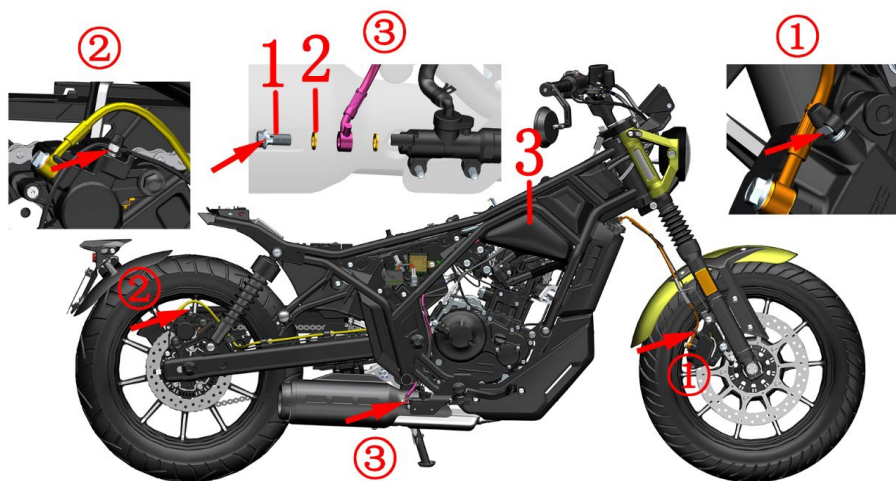

Fig.16 FRONT FORK COMPONENT		ABS brake system-A 1	CHK	⚠
			ADJ	
NO.	PART NO.	PART NAME	QTY	CAUTION
1	1251100-112000	Disc brake pipe bolt M10×1-22	1	30~32N·m
2	1251513-013000	Disc brake pipe copper washer φ 15× φ 10.2 × 1.5	2	
3	1226500-023000	KD200-C tool box	1	
4	1251100-328000	Hexagon socket head screw M6×14+8.5×3 SUS302	2	
5	1274100-053000	ZT250-S driver's tool	1	
6	1224300-110000	Reverse buckle Velcro strap (20×200mm)	1	
7	1244100-002000	ZT250-S Side cover round rubber	2	
8	1226500-025000	KD200-C tool box backing	1	
9	1186400-009000	ZT350 Dual Port Universal USB Charging Cable (A+C)	1	
10	1251100-061093	M6×22 Hex flang bolt thread level 8.8 (color zinc)	1	
11	1274100-057095	Flanging bushing φ6.2×φ8.4×3.5 + φ14×1.5	1	
12	1244100-052000	Buffer rubber of flanging bushing (φ8.5×φ14×1)	1	



## PROCEDURE:

## ● Hydraulic control unit components

Wear waterproof gloves and lift the bleeder nipple protection caps on the front and rear calipers and put on the hoses to collect the brake fluid. After placing the catch pan, remove the front brake main pump cover as described in Adding Brake Fluid to Front Brake Msin Pump. Loosen the bleeder nozzle with a 10# open-end spanner to drain the brake fluid. Do the same to drain the brake fluid from the rear calipers. Loosen the bolt at the rear brake main cylinder with a 12# socket, remove the rear brake msin cylinder oil cup cover and drain the brake fluid. Tighten the bleeder nipple after draining the brake fluid.

Remove the tool box cover(3) and then remove the 2 bolts(4) with 4# hex, remove the bolts(10) with 8# socket, remove the bushing(11) and Buffer rubber(12), and remove the tool box underlay assembly. If it is necessary to remove the driver's tool (6) then simply undo the strap(5). If the tool box backing(8) needs to be replaced, remove the side cover round rubber(7) and the USB charging cable(9) and install them on the new part.

## CAUTION:

- This description only roughly explains the disassembly steps, need to have some hands-on ability, it is recommended to qualified after-sales shop for maintenance.
- The seat cushion, fuel tank component, right side cover must be removed in advance.
- Be sure to disassemble the muffler and engine after they have cooled down completely. The horizontal support of the vehicle should be fixed before disassembly and assembly work.
- The precautions for brake fluid are described in the previous section.

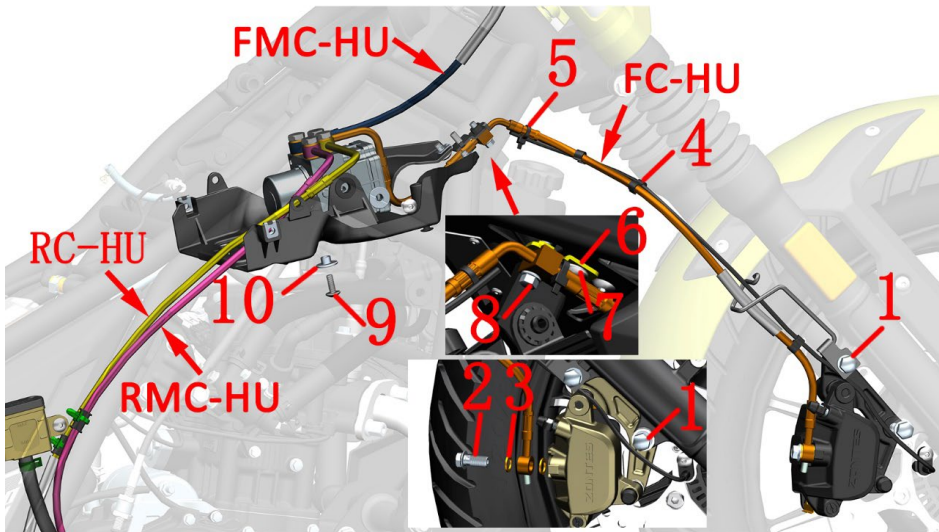

Fig.17 FRONT FORK COMPONENT		ABS brake system-A 2	CHK	🔧
			ADJ	
NO.	PART NO.	PART NAME	QTY	CAUTION
1	1251100-080094	Non-standard bolt M8×37	2	25N.m
2	1251100-112000	Disc brake pipe bolt M10×1-22	1	30~32N.m
3	1251513-013000	Disc brake pipe copper washer φ 15× φ 10.2 × 1.5	12	
4	1224100-044000	Wheel speed sensor clamp	3	
5	1224100-051000	0 level fire-retardant belting (black2.5×100)	2	
6	1100100-993000	KD200-C front oil inlet and outlet pipe limit bracket	1	
7	1251100-101000	Non-standard bolt M6×12 (304 stainless steel)	1	
8	1251100-061093	M6×22 Hex flang bolt thread level 8.8 (color Zinc)	1	
9	1251100-102000	Non-standard bolt M6×16 (304 stainless steel)	2	
10	1244100-004000	ZT250-S Flanging bushing buffer	2	
11	1251100-248000	Disc brake oil pipe hexagon head bolt M10 × 1 × 20	4	18~20N.m
12	1180300-101000	HJ150-3 square flasher (LED)	1	

## PROCEDURE:

## ● Hydraulic control unit components

First remove 3 pieces of clamps(4) and cut 2 beltings(5). Remove the bolts(8) with an 8# socket, or if you need to replace the limit bracket(6), remove the bolts(7) with a 4# hex.

Remove the 2 bolts(1) holding the front disc brake caliper with a 14# socket and let the caliper sag naturally. Wear waterproof gloves and use a 12# socket to remove the bolts(2), remove the copper washers (3), and remove the FC fluid line, being careful not to let the brake fluid flow onto the brake pads or discs.

Use a 14# sleeve to loosen the bolts of the 4 disc brake oil pipes and then tighten them slightly to prevent oil leakage.

Remove the flasher(12) from the electrical device box and unplug it if it needs to be replaced.

Remove the bolts(9) on the bottom of the front electrical box and on the right side of the hydraulic control unit with a 4# hex and remove the bushing buffer(10). Lift up the fluid control unit assembly and unplug it, then put a waterproof film under the fluid control unit assembly after wearing waterproof gloves to prevent brake fluid from dripping onto the motorcycle. Then remove the 4 bolts(11) and 8 pieces of copper washers(3) and the fluid control unit.

RC-HU is connected to the hydraulic control unit and rear brake caliper; RMC-HU is the rear disc brake main pump; FC-HU is the front disc brake caliper; FMC-HU is the front disc brake main pump.

## ● FMC-HU

The oil pipe, front disc brake main pump, rocker arm assembly and disassembly refer to the previous steps in "Adding brake fluid and rocker arm adjustment".

## CAUTION:

● It is recommended to replace the copper washers (3) at the same time when replacing the tubing or hydraulic control unit. The bolts (2) and (11) needn't to be replaced if they are not damaged.

● Be sure to disassemble the muffler and engine after they have cooled down completely. The horizontal support of the vehicle should be fixed before disassembly and assembly work.

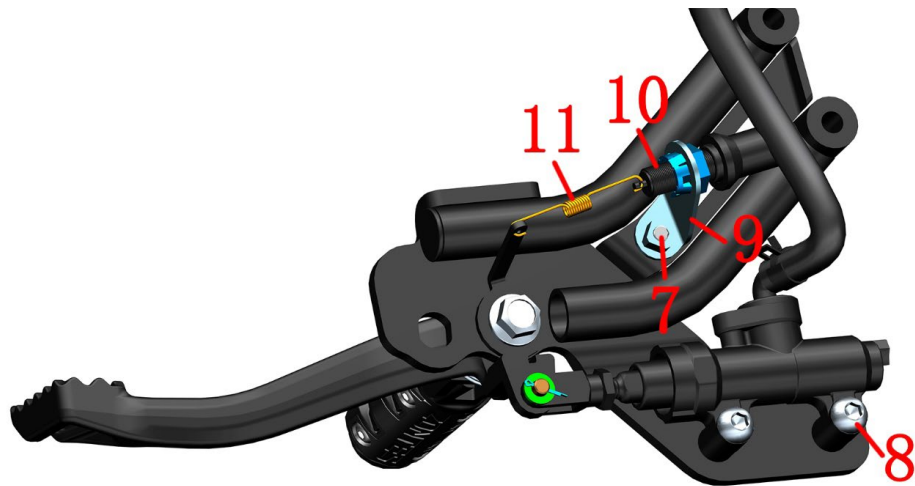
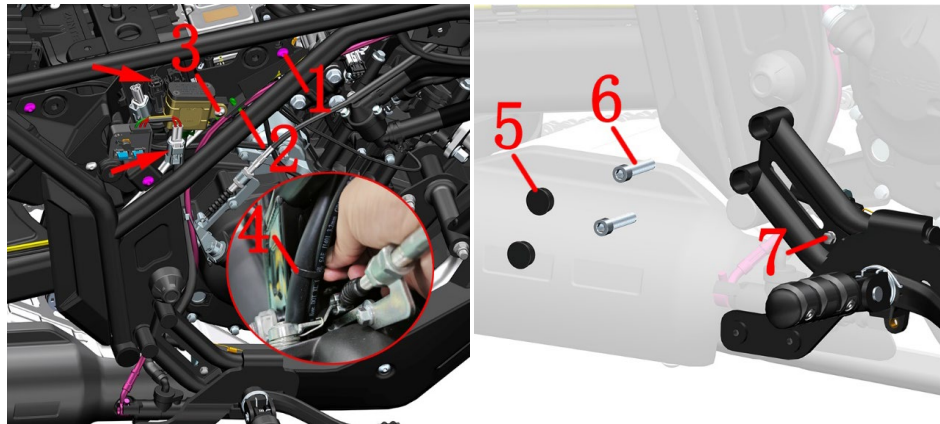

Fig.18 FRONT FORK COMPONENT		ABS brake system-A 3	CHK	
NO.	PART NO.	PART NAME	ADJ	
1	1251100-328000	Hexagon socket head screw M6×14+8.5×3 SUS302	3	CAUTION
2	1274100-017000	ZT250-S cable buckle	2	
3	1251100-101000	Non-standard bolt M6×12 (304 stainless steel)	1	
4	1224100-030000	Pin tie (Black 4.8×130)	1	
5	1244200-052000	ZT310 univرسال side box bracket waterproof rubber plug	2	
6	1250205-023000	GB70.1 inner hexagonal M8×35 (color Zinc)	2	
7	1250104-006097	GB16674M6×12 (chromed/HH)	1	
8	1251100-364000	Non-standard bolt M6×25 (environmental color/10.9 grade)	2	
9	1100101-024000	KD20-C rear brake switch bracket	1	
10	1186500-009000	KD20-C rear brake switch	1	
11		KD20-C rear brake switch spring	1	

**PROCEDURE:**

## ●RMC-HU

Remove the right side cover and right side cover bottom liner by referring to the method for removing the right side cover in the Side Cover Assembly section. Reach in from the back of the clutch cable and pinch the head of the tie wrap and push it outward to remove the tie wrap from the frame before cutting or undoing it. Remove the RMC and RC fuel lines from the wire fasteners on the side cover bottom liner and then remove the RMC-HU fuel line.

## ●Rear brake main pump

Remove the waterproof rubber plug(5) and remove the two bolts(6) with a 6# socket. Grasp the rear brake switch bracket(9) and then remove the bolt(7) with an 8# socket. Flip the footrest bracket assembly to the back. Remove the brake switch spring(11) from the switch(10) and remove the brake switch(10) from the bracket after pressing the catch on the brake switch nut.

Remove the rear brake main pump after removing its own circlip, pad and pin. Remove the rear brake main pump after removing the two bolts(8) with a 6# hex.

**CAUTION:**

- This description only roughly explains the disassembly steps, need to have some hands-on ability, it is recommended to qualified after-sales shop for maintenance.
- Be sure to disassemble the muffler and engine after they have cooled down completely. The horizontal support of the vehicle should be fixed before disassembly and assembly work.
- The precautions for brake fluid are described in the previous section.

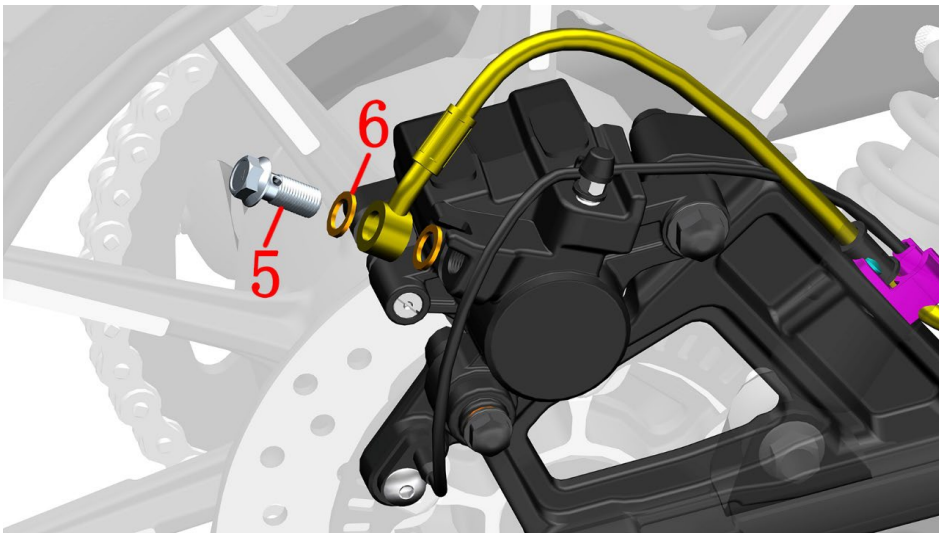
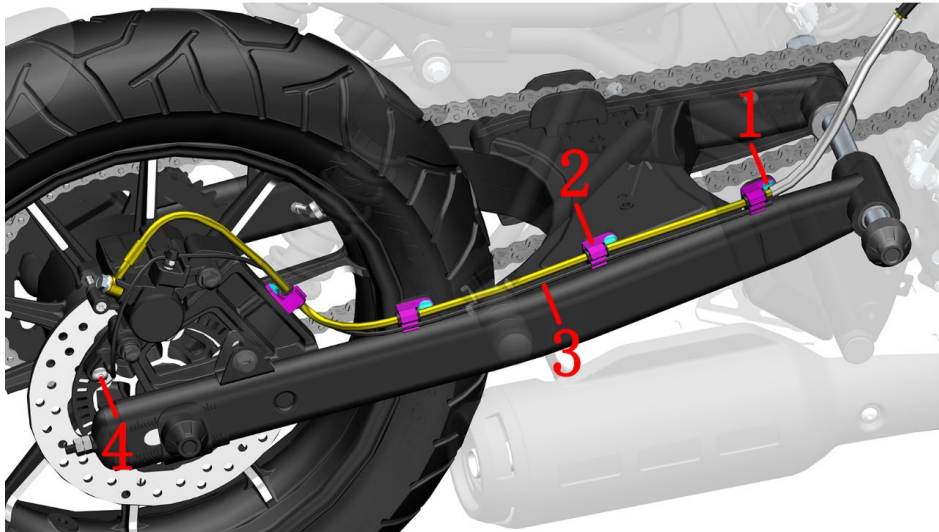

Fig.19 FRONT FORK COMPONENT		ABS brake system-A 4	CHK	
		ADJ		
NO.	PART NO.	PART NAME	QTY	CAUTION
1	1251100-101000	Non-standard bolt M6×12 (304 stainless steel)	4	
2	1224200-003000	ZT310-R Rear disc brake pipe clamp	4	
3	1181200-118000	Wheel speed sensor(A)	1	
4	1251100-102000	Non-standard bolt M6×16 (304 stainless steel)	1	
5	1251100-112000	Disc brake pipe bolt M10×1-22	1	30~32N·m
6	1251513-013000	Disc brake pipe copper washer φ 15× φ 10.2 × 1.5	2	

#### PROCEDURE:

##### ● Wheel speed sensor

Remove the wheel speed sensor cable(3) connector and pull it out.

Remove the sensor wire after removing the 4 pcs disc brake tubing clamps(2).

Using 4# inner hexagon socket remove the bolt(4), remove the exhaust rubber cap then take off the wheel speed sensor cable.

##### ● Rear disc brake caliper

Refer to the steps of removing the rear wheel assembly in the front, remove the rear axle nut and the right chain adjuster, and then retract the rear axle to the left to remove the rear disc brake caliper assembly. Put the rear axle, right chain adjuster and rear axle nut back into the rear fork.

##### ● RC-HU

Place the oil pan under the rear disc brake caliper.

After wearing the waterproof gloves, remove the bolts (5) with a 12# sleeve; remove the copper washers(6). If you need to replace the RC-HU tubing, it is recommended to replace the two copper washers(6) at the same time; the bolts(5) can be replaced if they are not damaged.

#### CAUTION:

● This description only roughly explains the disassembly steps, need to have some hands-on ability, it is recommended to qualified after-sales shop for maintenance.

● Be sure to disassemble the muffler and engine after they have cooled down completely. The horizontal support of the vehicle should be fixed before disassembly and assembly work.

● The precautions for brake fluid are described in the previous section.



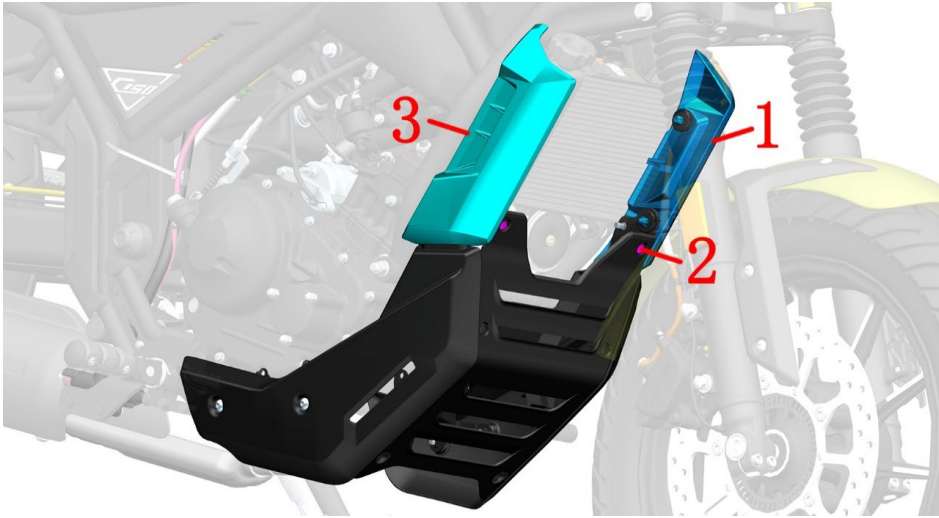

Fig.1 SURROUNDING COMPONENT		Decorative cover s the upper part component	CHK	
			ADJ	
NO.	PART NO.	PART NAME	QTY	CAUTION
1		KD200-C left surrounding upper part assembly	1	
2	1224100-010000	ZT250-S swell nail	5	
3		KD200-C right surrounding upper part assembly	1	
4	1251100-328000	Hexagon socket head screw M6×14+8.5×3 SUS302	6	

## PROCEDURE:

## ● Upper surrounding assembly:

Remove the two swell nails(2)above the centre of the surrounding. Firmly pull the left and right surrounding upper assemblies outward.

Use 4# inner hexagon to remove 6 bolts (4), take off the surrounding assembly.



## CAUTION:

- The parts should be protected during the disassembly process to prevent damage to the surface.
- When removing the buckle, pay attention to the strength to prevent damage to the buckle.

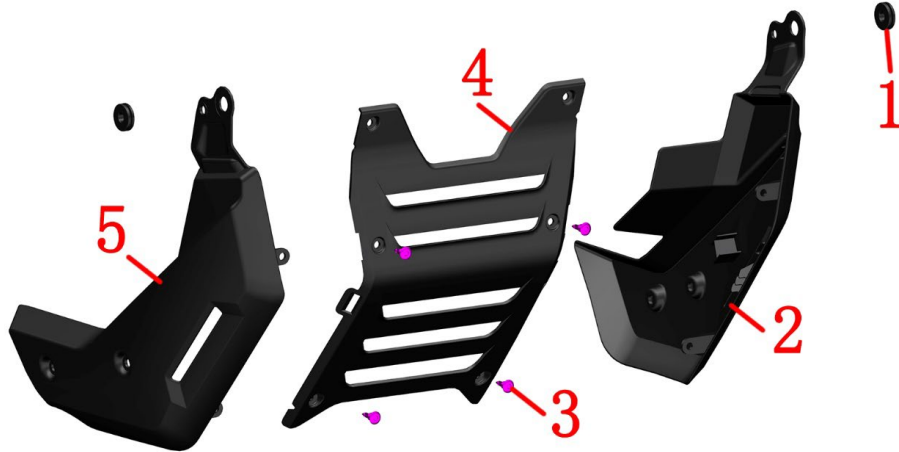
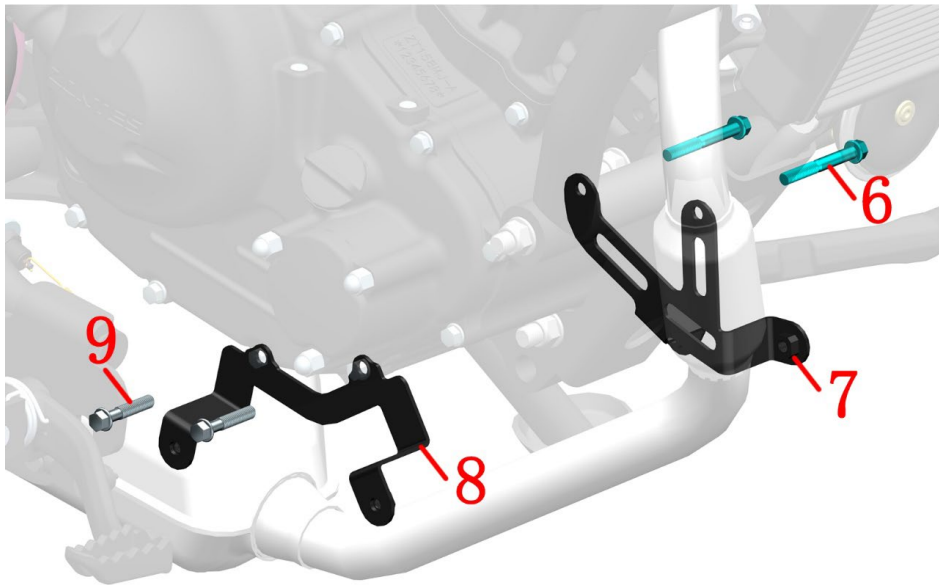

Fig.3 SURROUNDING COMPONENT		Lower part component	CHK	
NO.	PART NO.	PART NAME	ADJ	
1	1244100-002000	ZT250-S Side cover round rubber	2	
2		KD200-C left surrounding lower part assembly	1	
3	1224100-010000	ZT250-S swell nail	4	
4	1226500-012000	KD200-C surrounding middle cover	1	
5		KD200-C right surrounding lower part assembly	1	
6	1251112-003093	M6×45 Hexagon flange bolts (9.8 grade/ color Zinc)	2	
7	1276500-013021	KD200-C surrounding left lower bracket	1	
8	1276500-018000	KD150-C surrounding righttt lower bracket	1	125/155CC
	1276500-012021	KD200-C surrounding right lower bracket	1	200CC,[1]
9	1251112-002093	M6×30 Hexagon flange bolts (9.8 grade/ color Zinc)	2	[1]

**PROCEDURE:**

## ● Surrounding components

After removing the 4 swell nails(3), separate the surrounding left part, right part and centre part. Remove the round rubber(1) from the top of the left and right sections.

If the surrounding bracket needs to be replaced it can be removed by removing the bolt using an 8# socket. The bolts need to be put back on the engine promptly after removing the bracket.

**CAUTION:**

● The parts should be protected during the disassembly process.

● [1] The lower right bracket of the 200CC's surrounding uses different bolts than the 125/155CC's. The 200CC uses 2 x M6 x 45 and the 125/155 uses 2 x M6 x 30.

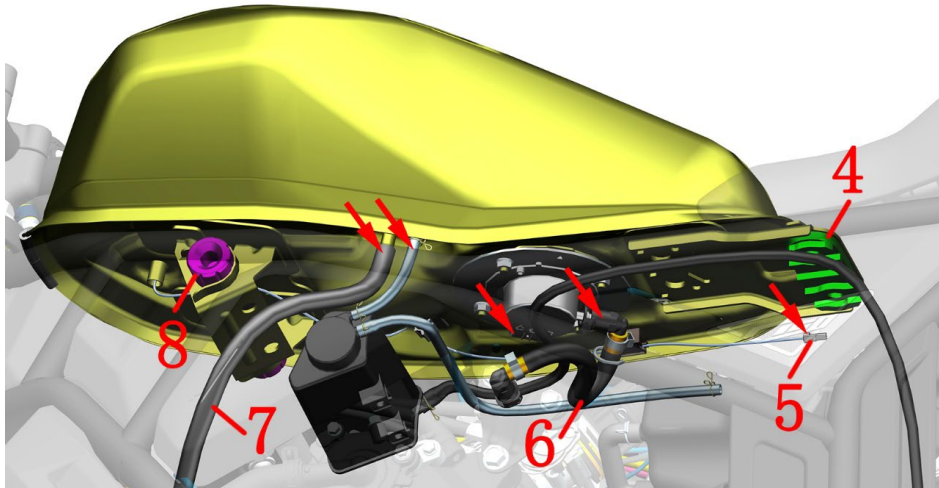
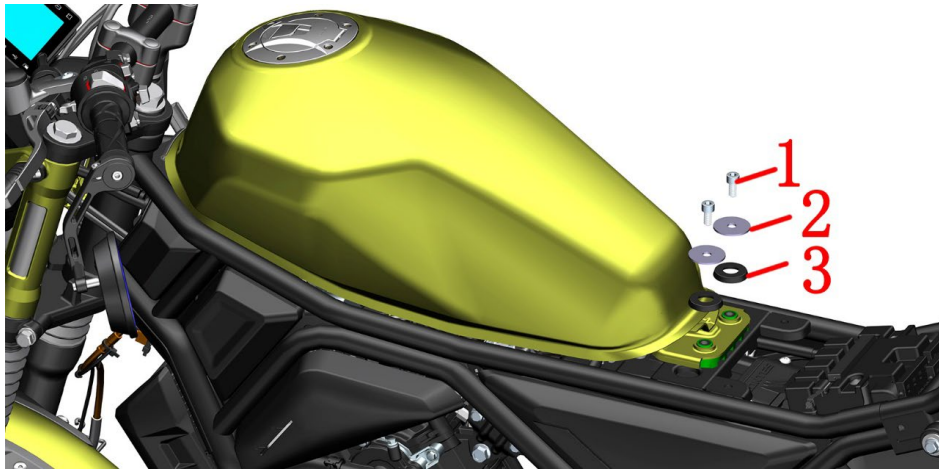

Fig.1 FUEL TANK COMPONENT		Fuel tank component	CHK	
NO.	PART NO.	PART NAME	ADJ	
1	1250205-040095	GB70.1 inner hex bolt M8×16(color Zinc)	2	CAUTION
2	1251900-028093	ZT250-R fuel tank flat pad φ9×φ37.5×2 (Zinc)	2	
3	1240300-076000	KD150-F oil tank press rubber	2	
4	1246500-011021	KD200-C fuel tank gasket	1	
5	1186500-011000	KD200-C electronic fuel tank lock base plate	1	
6	1050957-016000	KD200-C EFI high pressure oil pipe assembly	1	
7	1246500-026000	Fuel tank water leakage pipe Φ9×Φ14×730	1	
8	1241200-044000	KD150-U fuel tank liner limit glue	2	

## PROCEDURE:

## ● Fuel tank component

Press the "SEAT" button briefly to open the electronic cushion lock, unplug the tail light at the bottom of the right side of the seat cushion before taking off the seat cushion.

Use 6# inner hexagon to remove 2 bolts(1), take off the fuel tank flat pad(2) and remove the rubber(3).

Unplug the fuel tank lock base plate(4).

Grab the head of the fuel tank assembly with one hand and pull it back, while grabbing the tail with the other hand and lifting it up and wiggling it slightly left and right. Remove the fuel tank assembly from the fuel tank liner limit glue(8) of the frame. Unplug the fuel pump plug and high pressure oil pipe assembly(6) from the bottom of the right side after lifting the fuel tank up; use pliers to hold the clamps on the carbon canister adsorption pipe and fuel tank water leakage pipe(7) on the left side and pull them out. Remove the fuel tank assembly.

Remove the fuel tank gasket (4) and fuel tank liner limit glue(8).

## CAUTION:

- The parts should be protected during the disassembly process to prevent damage to the paint surface.
- When removing the buckle, pay attention to the strength to prevent damage to the buckle.
- When removing the high-pressure oil pipe, be sure to wait until the engine and muffler are completely cooled before operating to prevent accidental ignition of the fuel and cause fire.
- Fireworks, answering or dialing should be strictly prohibited near the car-breaking site to prevent accidents.
- A small amount of fuel leakage is required when the high-pressure oil pipe sub-assembly is pulled out, and the fuel should be prevented from dripping to the outside of the engine or the muffler.
- It is recommended to use the oil pump to pump out the fuel or consume the fuel before disassembling the tank assembly.

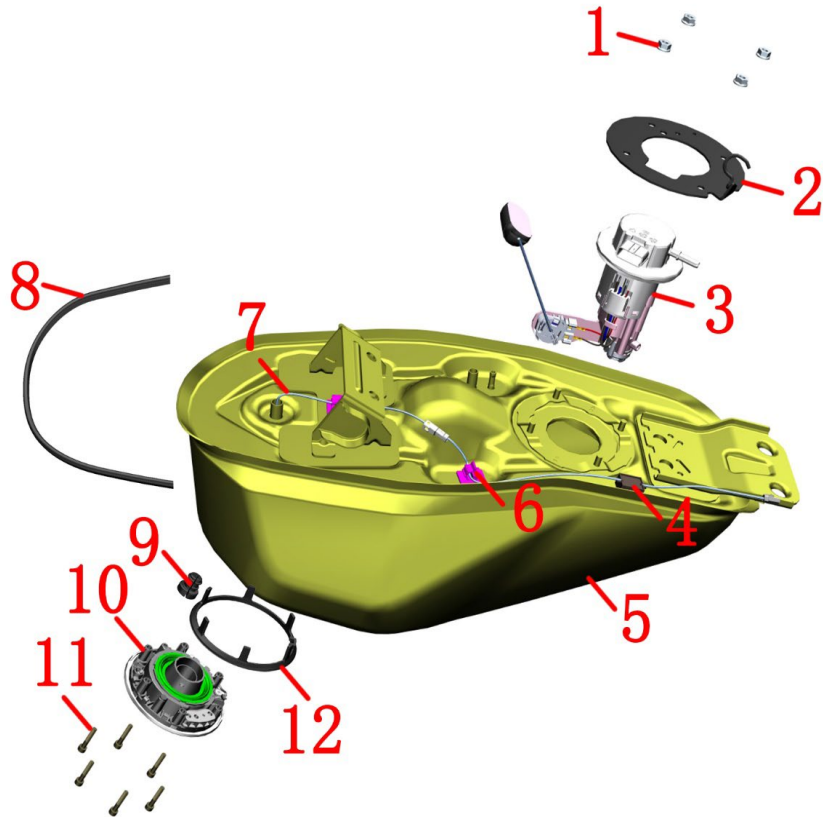

Fig.2 FUEL TANK COMPONENT		Fuel tank cover component	CHK	
NO.	PART NO.	PART NAME	ADJ	
1	1250303-010093	GB6177.1M6 (environmental color)	4	
2	1276500-015000	KD200-C oil pump end bracket	1	
3	1050956-035000	T04 built-in fuel pump (C/300KPa)	1	125/155CC
	1050957-017000	T04 built-in fuel pump (C/250KPa)	1	200CC
4	1186500-011000	KD200-C electronic fuel tank lock base plate	1	
5		FUEl tank	1	
6	1224200-066000	ZT310PKE External antenna mount	2	
7	1186500-004000	KD200-C electronic fuel tank lock adapter cable (cable length 470mm)	1	
8	1240300-021000	HJ125-6 pod glass strip (1.5m)	1	about 80cm
9	1246500-020000	KD200-C electronic fuel tank lock adapter waterproof rubber plugs	1	
10	1186800-021000	ZT200-C electronic fuel tank lock (matte black)	1	
11	1250205-135000	GB70.1M5×30 (304 stainless steel)	6	
12	1246800-003000	ZT703 electronic fuel tank lock dust proof rubber sleeve	1	

## PROCEDURE:

## ●Fuel tank assembly

It is recommended to use the oil pump to pump out the fuel or consume the fuel before disassembling the tank assembly.

Turn the tank assembly over so that the bottom is facing up and break off the clips to open the two antenna mounts<sup>(6)</sup>. Unplug the adapter cable<sup>(7)</sup> and the base plate<sup>(4)</sup>. Heat the fixing seat with a hot air gun and remove it when the double-sided adhesive of the fixing seat is softened. Remove the base plate<sup>(4)</sup> in the same way.

Use 10# socket to remove 4 nuts<sup>(1)</sup>, then remove the bracket<sup>(2)</sup>, remove the fuel pump<sup>(3)</sup>, pay attention to protect the cover of the fuel pump float linkage and fuel outlet.

Turn the fuel tank over and remove 6 bolts<sup>(11)</sup> with a 5# hex, pick up the fuel tank locking cover, and remove the fuel tank cover<sup>(10)</sup> after unplugging the adapter cable<sup>(7)</sup> from the fuel tank cover. Remove the waterproof rubber plug<sup>(9)</sup>. When assembling, take care not to omit the waterproof rubber plug<sup>(9)</sup> and the sealing ring that comes with the fuel tank cover (the sealing ring shown in green in the diagram).The rubber sleeve<sup>(12)</sup> increased since late March 2024, early production vehicles can be increased.

Remove the adapter cable<sup>(7)</sup> from the fuel tank.

## CAUTION:

●The parts should be protected during the disassembly process to prevent damage to the paint surface.

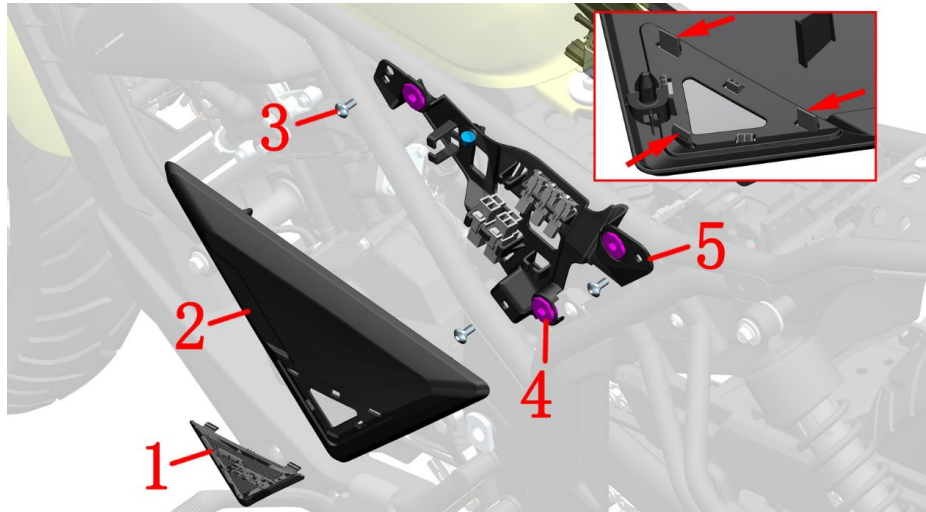

cover assembly, open the rubber plug and insert the charger DC plug. Then plug the AC socket into the 110-220V power supply. If the battery is damaged due to the use of inferior chargers, it is not within the scope of the Three Guarantees.

Fig.1 SIDE COVER COMPONENT		Side cover component	CHK	CAUTION
			ADJ	
NO.	PART NO.	PART NAME	QTY	
1		Left side cover decorative sticker	1	
2	4046502-010022	KD200-C left side cover (matte black)	1	
3	1251100-328000	Hexagon socket head screw M6×14+8.5×3 SUS302	6	
4	1244100-002000	ZT250-S Side cover round rubber	6	
5	1226500-014000	KD200-C left side cover underlay	1	
6	1251200-050094	Non-standard cross tapping screws ST3.9×12	1	
7	1226500-013000	KD200-C right side cover underlay	1	
8	1251300-063093	Plywood M6×11×15(color Zinc)	1	
9	1184300-003000	ZT350 charging port holder	1	
10	1184200-128000	ZT310 univ ersal fuse (15A small)	2	after-sale
11	4046502-011022	KD200-C right side cover (matte black)	1	
12		Right side cover decorative sticker	1	
13	1050954-009000	YH canister solenoid valve	1	
14	1250303-010093	GB6177.1M6 (environmental color)	1	
15	1274100-017000	ZT250-S cable buckle	1	
16	1251100-101000	Non-standard bolt M6×12 (304 stainless steel)	1	

#### PROCEDURE:

##### ● Left side cover assembly

Grasp the left side cover assembly and pulling it outwards, and remove the left side cover assembly by pulling out the mushroom clips at 3 places. Separate the side cover decorative sticker(1) from the left side cover(2) by prying off the 3 snaps indicated by the arrows.

Remove the side cover underlay assembly after removing all cable plugs and removing the 3 screws(3) with a 4# hex.

Remove the 3 pieces of side cover round rubber(4) from the side cover underlay(5).

##### ● Right side cover assembly

Remove the right side cover(11) and the right side cover decorative sticker(12), and separate them by referring to the previous steps.

Remove the bolt(16) securing the disc brake oil cup with a 4# hex, and remove the disc brake oil cup, taking care not to invert it to prevent air bubbles from entering the brake oil pipe.

Remove all other plugs and pull out the right side cover assembly after removing the 3 screws(3) with a 4# hex. Remove the 2 pieces of cable buckles(15).

Remove the nut(14) with a 10# open-end wrench and remove the carbon canister solenoid(13).

Turn over to the back and remove the charging port holder (9) after removing the cross tapping screw(6) with a Phillips screwdriver. Remove the 3-piece side cover round rubbers(4) and the plywood(8).

##### ● Charging

When the vehicle is not ridden for a long time or the battery feed cannot be started, remove the right side

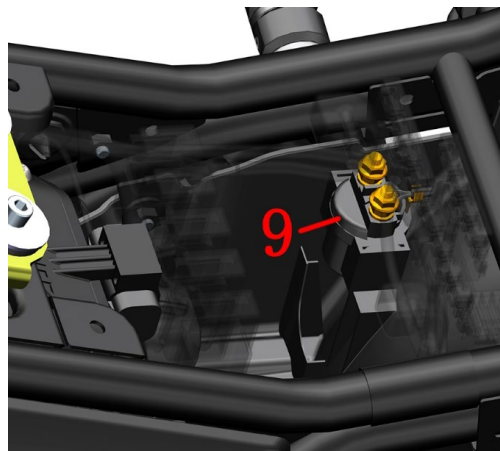
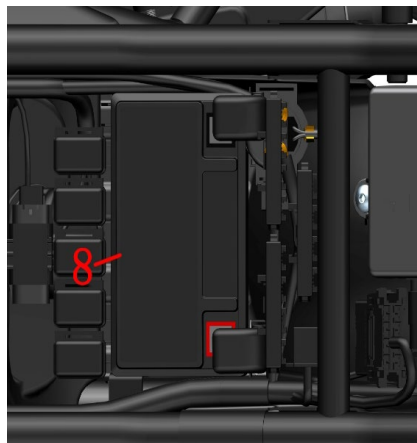
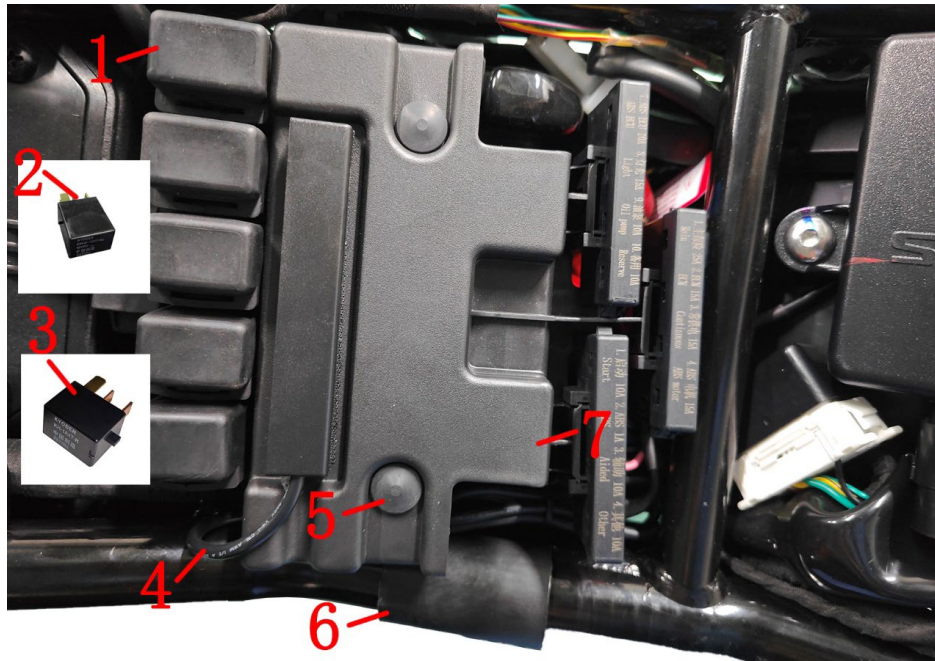

Fig.1 Rear Electrical device box component		Battery pack	CHK	
NO.	PART NO.		ADJ	
1	1244200-103000	ZT310 relay rubber sleeve	5	
2	1184200-024000	ZT310-R relay of side support	1	
3	1184100-017000	ZT250-S fuel-injection relay	4	
4	1184200-053000	ZT310PKE external single antenna	1	
5	1246300-001000	ZT125T-M main bracket buffer glue(19.5mm/HS55)	2	125/155CC
6	1240100-023000	Battery anode protection glue	1	
7	1226500-005000	KD200-C battery cover	1	
8	1186500-010000	KD125-C battery (9Ah)	1	125/155CC
	1186500-005000	KD200-C battery (12Ah)		200CC
9	1184300-002000	ZT350 starting relay	1	

**PROCEDURE:**

● The battery cover

Electrical Cover

Pull up the battery cover assembly and remove the 5 relay rubber sleeves(1) and 3 fuse boxes. If you need to replace the relays, remove the relay covers and pull out the corresponding relays.

Locate and unplug the PKE antenna and remove the battery cover. Remove the PKE antenna(4) and 2 pieces of buffer glue(5) from the battery cover. The buffer glue(5) is only for 125/155 displacement, and is not required for 200 displacement.

● Battery

Remove the negative terminal by disconnecting the black protective cap; then remove the positive terminal by disconnecting the red protective cap; remove the battery. For reinstallation, connect the positive terminal first, then the negative terminal.

Remove the fuse box and pull the starter relay(9) from the electrical device box without removing it. If replacing use a 10# socket to remove the nut after lifting the protective cover, locate the plug and pull it out.

**CAUTION:**

● Protect protective measures to prevent scratching the appearance of parts.

● When reassembling, check whether there is any pressure on the wire to prevent short circuit when tightening the bolt.

● If you need to replace the battery cover, it is recommended to purchase a piece of "1226400-188000 Velcro (external single antenna )" for pasting PKE antenna.

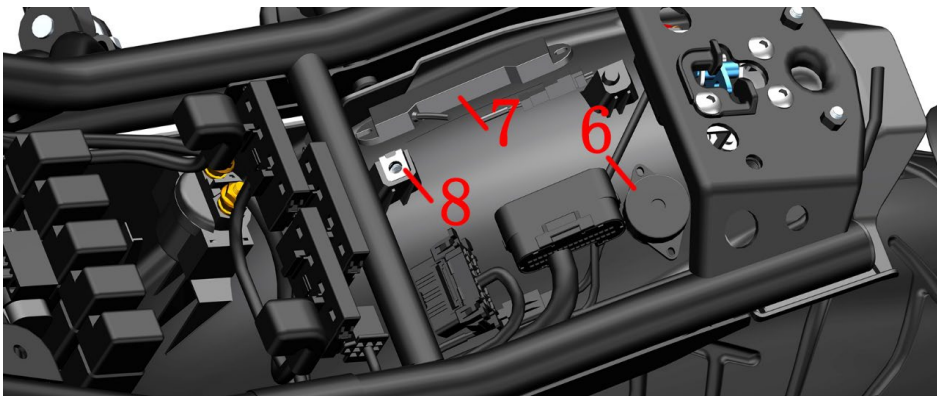
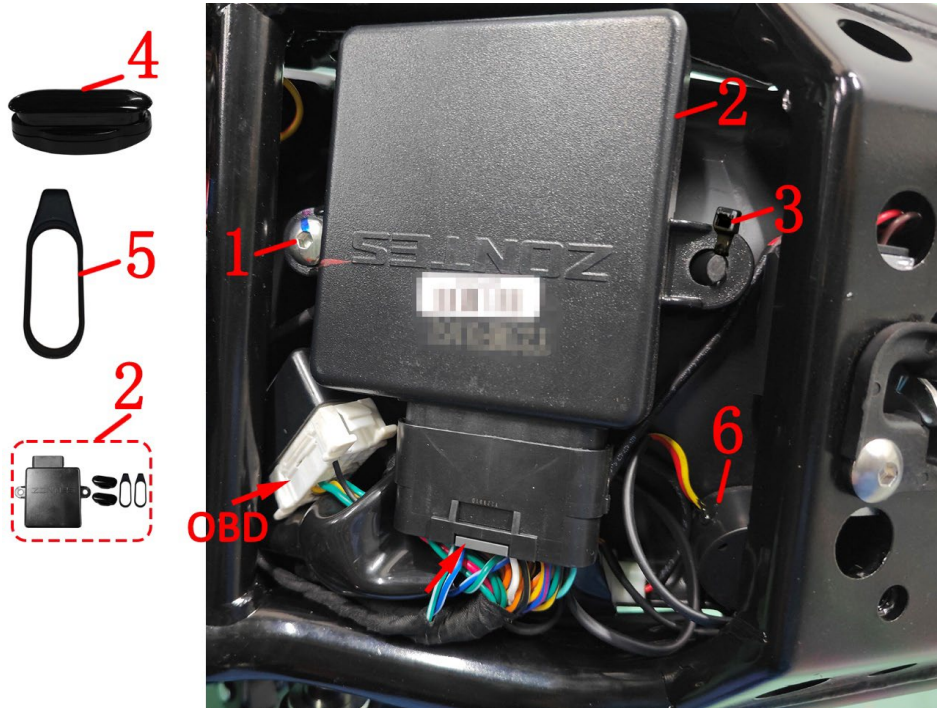

Fig.2 Rear Electrical device box component		Rear electrical device box component 1	CHK	⚠
			ADJ	
NO.	PART NO.	PART NAME	QTY	CAUTION
1	1251100-328000	Hexagon socket head screw M6×14+8.5×3 SUS302	1	
2	1184300-076000	2.5 Generation PKE Assembly (enlarge battery induction key)	1	
3	1224100-037000	Grade 0 flame retardant tie (black 3.6×295)	1	
4	1184200-210000	ZT310 Induction Key (Bracelet Edition-Big battery)	1	after-sale
5	1244200-100000	ZT310 induction key rubber ring	1	after-sale
6	1184200-016000	ZT310 PKE Buzzer	1	
7	1184300-005000	ZT350 antenna	1	
8	1251300-063093	Plywood M6×11×15(color Zinc)	1	

**PROCEDURE:**

● PKE

Remove the screw(1) with a 4# hexagonal socket, lift the PKE and then unplug the PKE by pressing the catch at the arrow. Cut the tie(3).

Locate and unplug the cushion lock and buzzer on the left side. Remove the buzzer(6).

Locate and unplug the powerless induction antenna(7)on the right side. The powerless induction antenna may not be removed.

Remove the OBD protective cap and connect the tester to read the fault code of EFI or ABS.

Remove the Plywood(8) from the electrical device box.

**CAUTION:**

● The cushion,side cover, rear armrest ,part of the rear cover,taillight, rear fender assemblyneed to be removed in advance.

● Protect protective measures to prevent scratching the appearance of parts.

● When reassembling, check whether there is any pressure on the wire to prevent short circuit when tightening the bolt.

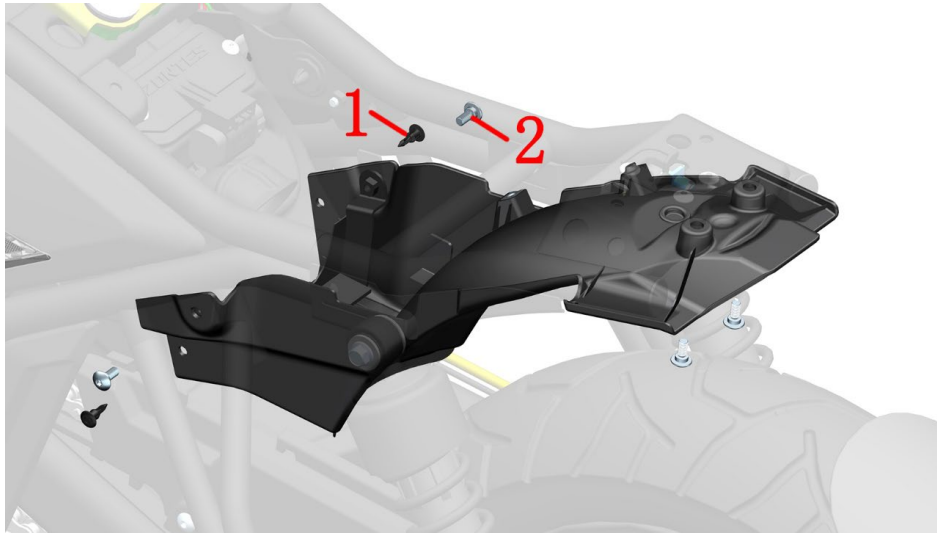



Fig.3 Rear Electrical device box component		Rear electrical device box component 2	CHK	
			ADJ	
NO.	PART NO.	PART NAME	QTY	CAUTION
1	1224100-010000	ZT250-S swell nail	2	
2	1240300-007000	Hexagon socket head screw M6×14+8.5×3 SUS302	4	
3	1276500-016000	KD200-C battery bracket	1	
4	1240300-007000	HJ125-6 Battery rubber gasket	2	
5	1226500-006000	KD200-C rear electrical device box	1	
6	1246500-015000	KD200-C rear electrical device box rubber stopper	1	

## PROCEDURE:

## ● Electrical device box assembly

Remove the 2 swell nails(1) under the head, and remove the 4 head screws(2) with a 4# hexagonal socket. Remove the electrical device box assembly.

If necessary, use a hot air gun to heat the double-sided adhesive back and forth until it softens, and then tear off the battery rubber gasket(4) from the battery bracket(3).

Remove the rubber stopper(6) from the electrical device box(5).

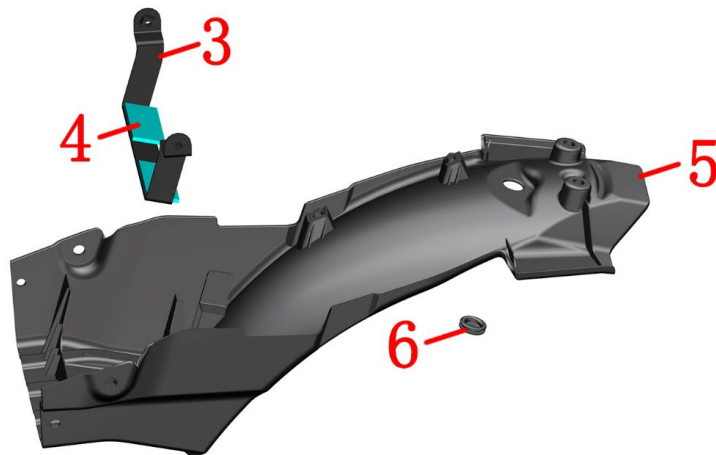

## CAUTION:

● The cushion, side cover, rear armrest, part of the rear cover, taillight, rear fender assembly need to be removed in advance.

● Protect protective measures to prevent scratching the appearance of parts.

● When reassembling, check whether there is any pressure on the wire to prevent short circuit when tightening the bolt.





Fig.1 CUSHION COMPONENT		Cushion component	CHK	REMARKS
NO.	PART NO.	PART NAME	ADJ	
1	4120100-026021	KD200-C cushion	1	Cushion included
2	1010502-045000	KD200-C seat cushion belt	1	
3	1244100-025000	ZT250-S round cushion rubber	3	
4	1244300-033000	ZT350 cushion rubber	2	
5	1251100-102000	Non-standard bolt M6×16 (304 stainless steel)	2	
6	1176500-003000	KD200-C-B1 tail light	1	
7	1251100-328000	Hexagon socket head screw M6×14+8.5×3 SUS302	2	
8	1246400-089021	ZT350T-D round cushion rubber	2	after-sale



## PROCEDURE:

## ● Remove the cushion

Press the unlock button shortly. After the power-on self test is completed, press the "SEAT" button briefly to open the electronic cushion lock.

Grasp the seat cushion(1) and pull it diagonally upwards. At the same time, remove the cushion by moving the rear part of the cushion from side to side. After lifting the cushion tail skirt be sure to unplug the tail light on the right side of the cushion before removing the cushion assembly.

## ● Assembly cushion

When assembling the cushion, check whether all the cushion rubbers are complete. Insert the front part of the cushion first. After the assembly is in place, shoot the rear part of the cushion firmly. When you hear the "click" sound, it indicates that the cushion lock has been assembled.

## ● Tail light

Using 4# allen key remove 2 pcs bolts (7), then take off the tail light (6).

## CAUTION:

- The motorcycle should be fixed before operation.
- Cushion can cause accidents if it is not installed properly.
- The rear 2 pcs cushion rubbers changed after January 19, 2024.

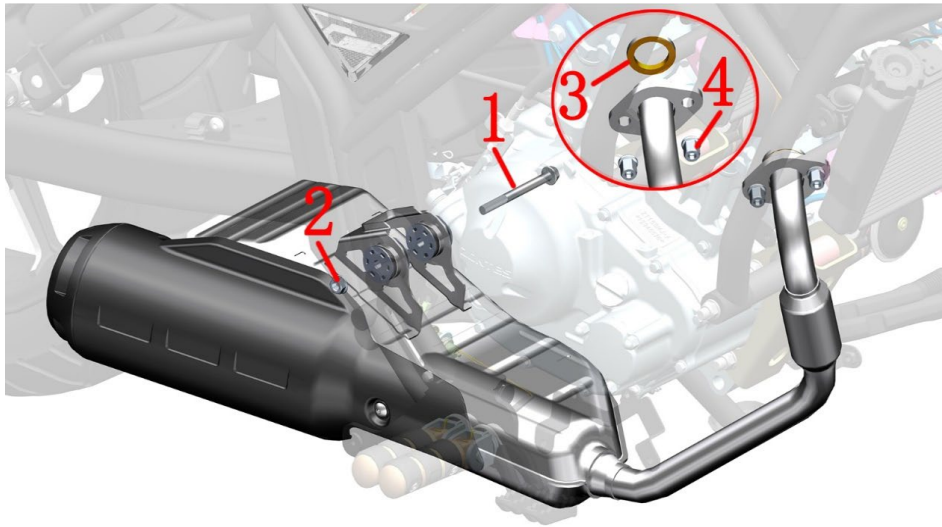

OPEN ENDED SPANNER WITH RING RATCHET

Fig.1 MUFFLER COMPONENT		Muffler component 1	CHK	
NO.	PART NO.	PART NAME	ADJ	
1	1250105-021091	GB5789 M8×90 (White zinc)	1	CAUTION
2	1250303-011093	GB6177.1 M8 (environmental color)	1	
3	1070100-202000	KD150-U engine exhaust seal pad	1	
4	1251300-058093	Inner hexagonal nut M8 (color zinc)	2	

#### PROCEDURE:

##### ●Remove the muffler component

The steps of removing muffler component of 125/155/200 for Euro V and 125 Euro V+ are same. , taking the Euro V as an example.

First remove the front grille component.

Fixed bolt <sup>(1)</sup> with 1/2ratchet wrench and 12# sleeve,Remove the nut <sup>(2)</sup> use a 72-tooth 13# open ended spanner with ring ratchet ,then take out the bolt <sup>(1)</sup>.

Using 12# sleeve or 6# allen key remove nuts <sup>(4)</sup>,

Hold the bottom of the fender return pressure package with one hand, and grab the flange at the exhauster to remove it. Wrap the flange with a rubber band or rope to prevent the flange from moving back and forth on the front elbow and causing scratches.

Take off the exhaust seal pad <sup>(3)</sup> from the exhaust.

#### CAUTION:

- The parts should be protected during disassembly to prevent damage to the paint.
- The muffler should be completely cooled before it is disassembled.
- Prevent foreign matter from entering the interior of the muffler.
- The muffler nozzle needs to be protected. If there is any deformation, it may cause air leakage.
- It is recommended that new seals be replaced each time the muffler front assembly is removed to prevent airleakage.

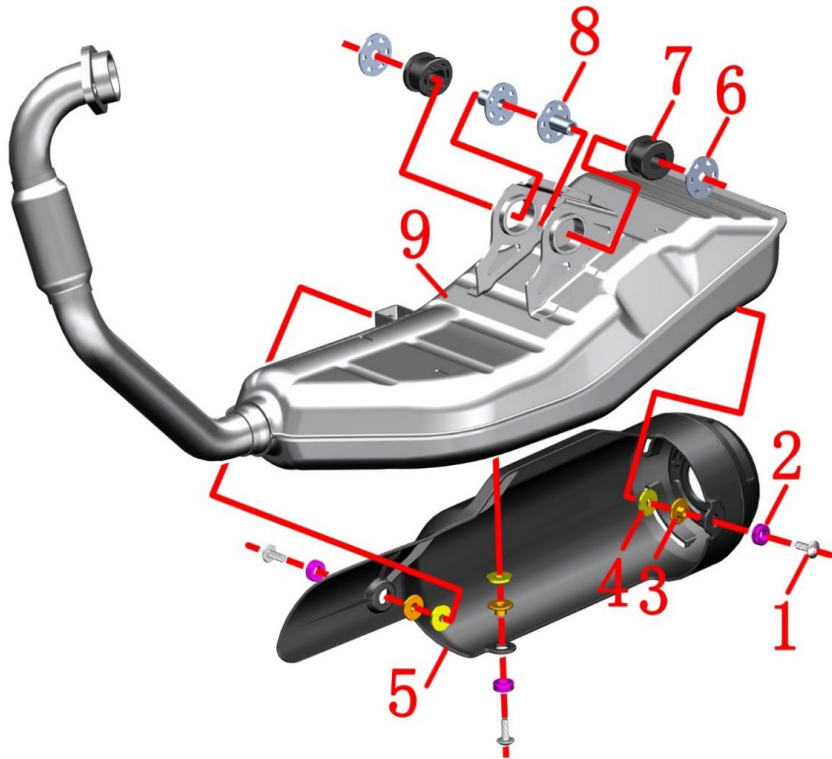

Fig.2 MUFFLER COMPONENT		Muffler component 2 ( Euro V )	CHK	
NO.	PART NO.	PART NAME	ADJ	
1	1251100-102000	Non-standard bolt M6×16 (304 stainless steel)	3	CAUTION
2	1244100-017000	ZT250-S muffler hot plate rubber buffer	3	
3	1274100-007000	ZT250-S flanging sleeve(φ6.4×φ9×6+φ20×2)	3	
4	1270300-201000	Stainless steel heat insulation mat 6×20×1.6	3	
5	4046502-001000	KD200-C muffler tail cover	1	
6	1020243-098000	ZT350 muffler gasket (φ8.3×φ33×1.5)	2	
7	1244300-022000	ZT350-GK-H1 muffler suspension hollow cushioning rubber	2	
8	1020243-097000	ZT350 muffler flanging bushing (φ8.3×φ11.5×20.5×φ8.4×φ33×1.5)	2	
9	4086500-006000	KD150-C-H2 Muffler (Homemade/Euro V)	1	125/155CC
	4086500-005000	KD200-C-H2 Muffler (Homemade/Euro V)		200CC

#### PROCEDURE:

##### ● Muffler componet

Remove the 3 bolts(1) with a 4# hexagonal socket, starting with the muffler tail cover assembly and the 3 pieces of mats (4); remove the sleeve(3) and rubber buffer(2) from the muffler tail cover assembly. Be sure to take care not to miss the mats (4).

Remove the gasket (6)and bushing(7).

Take off 2pcs cushion rubbe(7) from the muffler(9).

#### CAUTION:

- The parts should be protected during disassembly to prevent damage to the paint.
- The muffler should be completely cooled before it is disassembled.
- Prevent foreign matter from entering the interior of the muffler.

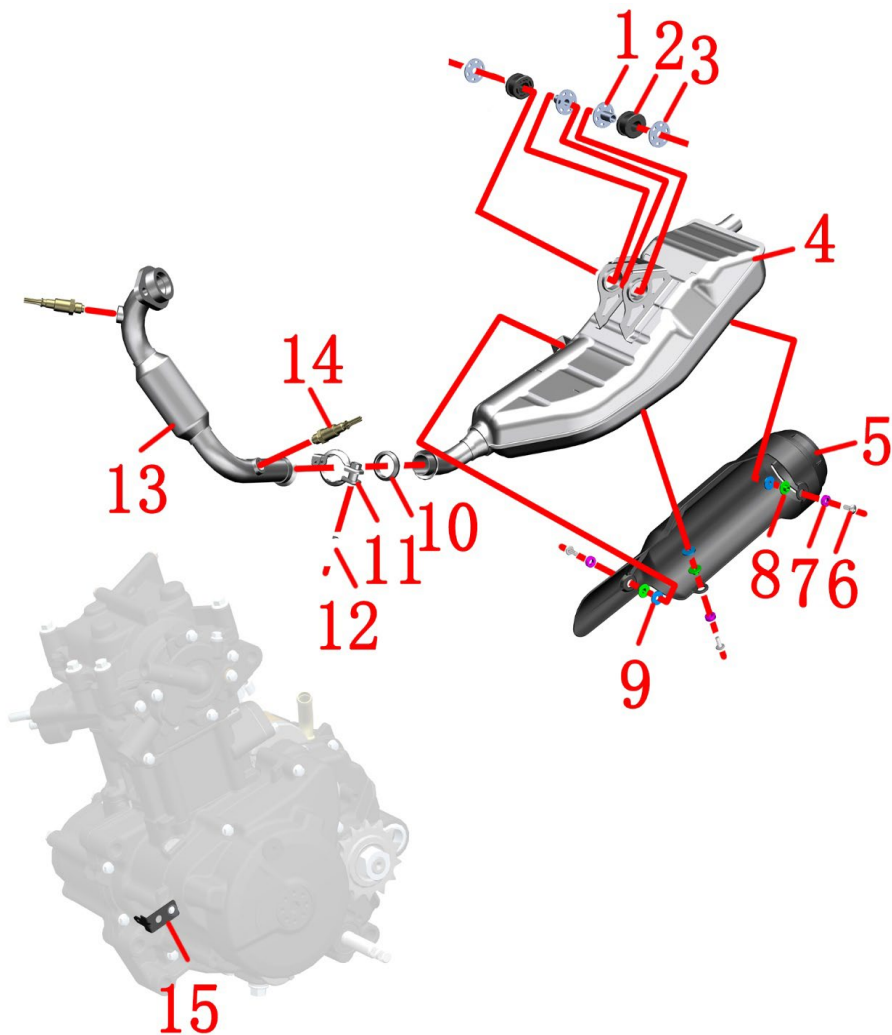

Fig.3 MUFFLER COMPONENT		Muffler component 2 (Euro V+)	CHK	
NO.	PART NO.	PART NAME	ADJ	
1	1020243-097000	ZT350 muffler flanging bushing (φ8.3×φ11.5×20.5×φ8.4×φ33×1.5)	2	CAUTION
2	1244300-022000	ZT350-GK-H1 muffler suspension hollow cushioning rubber	2	
3	1020243-098000	ZT350 muffler gasket (φ8.3×φ33×1.5)	2	
4	4086500-016000	KD125-C-H3 rear muffler (self-made/Europe V+)	1	125CC
5	1251100-102000	Non-standard bolt M6×16 (304 stainless steel)	3	
6	1244100-017000	ZT250-S muffler hot plate rubber buffer	3	
7	1274100-007000	ZT250-S flanging sleeve(φ6.4×φ9×6 + φ20×2)	3	
8	1270300-201000	Stainless steel heat insulation mat 6×20×1.6	3	
9	4046502-001000	KD200-C muffler tail cover	1	
10	1124300-004000	ZT350-GK muffler graphite gasket(37.8×28×11)	1	
11	1274100-074000	ZT310-R Muffler stainless steel bar clasp	1	
12	1250205-171000	GB70.2M8×30 (Stainless Steel A2 - 70)	1	
13	4086500-014000	KD125-C-H3 front muffler (self-made/Europe V+)	1	125CC
14	1050957-022000	Bosch Oxygen Sensor (LSFMH)	1	
15	1276500-057000	ZT125-C Oxygen Sensor bracket	1	

## PROCEDURE:

## ●Muffler componet

Remove the gasket<sup>(3)</sup>and bushing<sup>(1)</sup>.

Take off 2pcs cushion rubbe<sup>(2)</sup> from the muffler<sup>(4)</sup>.

Remove the 3 bolts<sup>(6)</sup> with a 4# hexagonal socket, starting with the muffler tail cover assembly and the 3 pieces of mats <sup>(9)</sup>; remove the sleeve<sup>(8)</sup> and rubber buffer<sup>(7)</sup> from the muffler tail cover assembly. Be sure to take care not to miss the mats <sup>(9)</sup>.

Remove the Oxygen Sensor<sup>(14)</sup> with 16# sleeve.

Remove the bolt <sup>(12)</sup> with a 6# hexagonal socket,then take off the clasp<sup>(11)</sup>.Then take off the front muffler <sup>(13)</sup>,remove the gasket<sup>(10)</sup>.

If you need change the bracket<sup>(15)</sup>,you should be remove the bolt fixing the bracke for 8# sleeve.And then take off the bracket.

## CAUTION:

- The parts should be protected during disassembly to prevent damage to the paint.
- The muffler should be completely cooled before it is disassembled.
- Prevent foreign matter from entering the interior of the muffler.